

# BlueDev+S42 Development Kit User Guide

1VV0301314 Rev. 1 – 2017-04-20



## APPLICABILITY TABLE

PRODUCT
BlueDev+S42



*SPECIFICATIONS SUBJECT TO CHANGE WITHOUT NOTICE*

**Notice**

While reasonable efforts have been made to assure the accuracy of this document, Telit assumes no liability resulting from any inaccuracies or omissions in this document, or from use of the information obtained herein. The information in this document has been carefully checked and is believed to be entirely reliable. However, no responsibility is assumed for inaccuracies or omissions. Telit reserves the right to make changes to any products described herein and reserves the right to revise this document and to make changes from time to time in content hereof with no obligation to notify any person of revisions or changes. Telit does not assume any liability arising out of the application or use of any product, software, or circuit described herein; neither does it convey license under its patent rights or the rights of others.

It is possible that this publication may contain references to, or information about Telit products (machines and programs), programming, or services that are not announced in your country. Such references or information must not be construed to mean that Telit intends to announce such Telit products, programming, or services in your country.

**Copyrights**

This instruction manual and the Telit products described in this instruction manual may be, include or describe copyrighted Telit material, such as computer programs stored in semiconductor memories or other media. Laws in the Italy and other countries preserve for Telit and its licensors certain exclusive rights for copyrighted material, including the exclusive right to copy, reproduce in any form, distribute and make derivative works of the copyrighted material. Accordingly, any copyrighted material of Telit and its licensors contained herein or in the Telit products described in this instruction manual may not be copied, reproduced, distributed, merged or modified in any manner without the express written permission of Telit. Furthermore, the purchase of Telit products shall not be deemed to grant either directly or by implication, estoppel, or otherwise, any license under the copyrights, patents or patent applications of Telit, as arises by operation of law in the sale of a product.

**Computer Software Copyrights**

The Telit and 3rd Party supplied Software (SW) products described in this instruction manual may include copyrighted Telit and other 3rd Party supplied computer programs stored in semiconductor memories or other media. Laws in the Italy and other countries preserve for Telit and other 3rd Party supplied SW certain exclusive rights for copyrighted computer programs, including the exclusive right to copy or reproduce in any form the copyrighted computer program. Accordingly, any copyrighted Telit or other 3rd Party supplied SW computer programs contained in the Telit products described in this instruction manual may not be copied (reverse engineered) or reproduced in any manner without the express written permission of Telit or the 3rd Party SW supplier. Furthermore, the purchase of Telit products shall not be deemed to grant either directly or by implication, estoppel, or otherwise, any license under the copyrights, patents or patent applications of Telit or other 3rd Party supplied SW, except for the normal non-exclusive, royalty free license to use that arises by operation of law in the sale of a product.



## Usage and Disclosure Restrictions

### License Agreements

The software described in this document is the property of Telit and its licensors. It is furnished by express license agreement only and may be used only in accordance with the terms of such an agreement.

### Copyrighted Materials

Software and documentation are copyrighted materials. Making unauthorized copies is prohibited by law. No part of the software or documentation may be reproduced, transmitted, transcribed, stored in a retrieval system, or translated into any language or computer language, in any form or by any means, without prior written permission of Telit.

### High Risk Materials

Components, units, or third-party products used in the product described herein are NOT fault-tolerant and are NOT designed, manufactured, or intended for use as on-line control equipment in the following hazardous environments requiring fail-safe controls: the operation of Nuclear Facilities, Aircraft Navigation or Aircraft Communication Systems, Air Traffic Control, Life Support, or Weapons Systems (High Risk Activities"). Telit and its supplier(s) specifically disclaim any expressed or implied warranty of fitness for such High Risk Activities.

### Trademarks

TELIT and the Stylized T Logo are registered in Trademark Office. All other product or service names are the property of their respective owners.

### Third Party Rights

The software may include Third Party Right software. In this case you agree to comply with all terms and conditions imposed on you in respect of such separate software. In addition to Third Party Terms, the disclaimer of warranty and limitation of liability provisions in this License shall apply to the Third Party Right software.

TELIT HEREBY DISCLAIMS ANY AND ALL WARRANTIES EXPRESS OR IMPLIED FROM ANY THIRD PARTIES REGARDING ANY SEPARATE FILES, ANY THIRD PARTY MATERIALS INCLUDED IN THE SOFTWARE, ANY THIRD PARTY MATERIALS FROM WHICH THE SOFTWARE IS DERIVED (COLLECTIVELY "OTHER CODE"), AND THE USE OF ANY OR ALL THE OTHER CODE IN CONNECTION WITH THE SOFTWARE, INCLUDING (WITHOUT LIMITATION) ANY WARRANTIES OF SATISFACTORY QUALITY OR FITNESS FOR A PARTICULAR PURPOSE.

NO THIRD PARTY LICENSORS OF OTHER CODE SHALL HAVE ANY LIABILITY FOR ANY DIRECT, INDIRECT, INCIDENTAL, SPECIAL, EXEMPLARY, OR CONSEQUENTIAL DAMAGES (INCLUDING WITHOUT LIMITATION LOST PROFITS), HOWEVER CAUSED AND WHETHER MADE UNDER CONTRACT, TORT OR OTHER LEGAL THEORY, ARISING IN ANY WAY OUT OF THE USE OR DISTRIBUTION OF THE OTHER CODE OR THE EXERCISE OF ANY RIGHTS GRANTED UNDER EITHER OR BOTH THIS LICENSE AND THE LEGAL TERMS APPLICABLE TO ANY SEPARATE FILES, EVEN IF ADVISED OF THE POSSIBILITY OF SUCH DAMAGES.

Copyright © Telit Communications S.p.A. 2017.



## Contents

<b>1. Introduction</b> .....	<b>7</b>
1.1. Scope.....	7
1.2. Audience .....	7
1.3. Contact Information, Support .....	7
1.4. Text Conventions .....	7
1.5. Related Documents.....	8
<b>2. Package Content</b> .....	<b>9</b>
<b>3. Hardware</b> .....	<b>10</b>
3.1. BlueMod+S42 .....	10
3.2. Reset.....	10
3.3. USB Interface.....	10
3.4. LEDs .....	11
3.5. External Low Power Oscillator .....	11
3.6. Connectors / Jumpers .....	11
3.6.1. Jumper J1 and Jumper J2.....	11
3.6.2. Jumper J3.....	11
3.6.3. Jumper J4.....	12
3.6.4. Connector X2.....	12
3.6.5. Connector X3.....	12
3.6.6. Connector X4.....	13
3.6.7. Connector X5.....	13
3.7. Current Measurement .....	13
3.8. Power Supply .....	14
3.8.1. USB Power Supply .....	14
3.8.2. External Power Supply.....	14
3.8.3. Battery Holder.....	14
3.9. Buzzer .....	14
3.10. Push Button .....	14
3.11. How To Interface the UART Lines on TTL Level .....	15
3.12. Default Configuration .....	16
<b>4. Setup</b> .....	<b>17</b>
4.1. System Requirements .....	17



- 4.2. Startup..... 17
- 4.3. Installation of the BlueDev+S42 USB Driver ..... 17
- 4.4. Installing the Debugger ..... 18
- 4.5. Connecting the nRF5 DK to the BlueDev+S42 ..... 18
- 4.6. Downloading and Installing the nRF5 SDK ..... 19
- 5. Usage of the BlueDev+S42 ..... 20**
  - 5.1. Telit Demo Source Code ..... 20
  - 5.2. BlueDev+S42 Software Package Structure..... 20
    - 5.2.1. The Directory “app\_template” ..... 20
    - 5.2.2. The Directory “common” ..... 21
    - 5.2.3. The Directory “include”..... 21
  - 5.3. Using the Demo Application ..... 22
    - 5.3.1. Demo Application Advertising ..... 22
    - 5.3.2. Telit Manual Test Mode ..... 23
- 6. Document History..... 24**





# 1. Introduction

## 1.1. Scope

This document describes the usage of the development kit for the Bluetooth module BlueMod+S42.

## 1.2. Audience

This document is intended for Telit customers, especially system integrators, about to implement Bluetooth modules in their application.

## 1.3. Contact Information, Support

For general contact, technical support, to report documentation errors and to order manuals, contact Telit Technical Support Center (TTSC) at:

[TS-SRD@telit.com](mailto:TS-SRD@telit.com)

Alternatively, use:

<http://www.telit.com/support>

For detailed information about where you can buy the Telit modules or for recommendations on accessories and components visit:

<http://www.telit.com>

To register for product news and announcements or for product questions contact Telit Technical Support Center (TTSC).

Our aim is to make this guide as helpful as possible. Keep us informed of your comments and suggestions for improvements.

Telit appreciates feedback from the users of our information.

## 1.4. Text Conventions



***Danger – This information MUST be followed or catastrophic equipment failure or bodily injury may occur.***



***Caution or Warning – Alerts the user to important points about integrating the module, if these points are not followed, the module and end user equipment may fail or malfunction.***



**Tip or Information – Provides advice and suggestions that may be useful when integrating the module.**



All dates are in ISO 8601 format, i.e. YYYY-MM-DD.

## 1.5. Related Documents

- [1] BlueMod+S42 Hardware User Guide
- [2] BlueMod+S42 Test Mode Reference
- [3] BlueEva+S42 Schematic





## 2. Package Content

The BlueDev+S42 package contains the following components:

- Telit demo source code (requires nRF5 SDK v11.0.0, not included)
- 1 x BlueDev+S42 board
- 1 x NFC Antenna Class6/V1.0
- 1 x Mini USB cable
- 1 x Battery CR2032
- 1 x 10-pin debugger cable
- 1 x Printed card with download instructions



Figure 1: BlueDev+S42 package content

### 3. Hardware

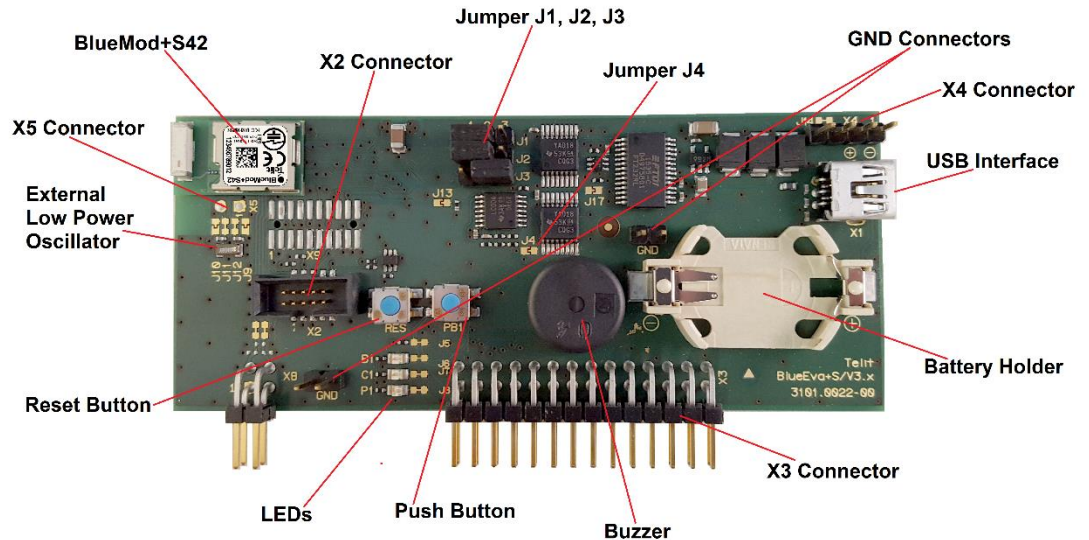

Figure 2: BlueDev+S42

#### 3.1. BlueMod+S42

The BlueDev+S42 is equipped with a BlueMod+S42 Bluetooth module.

#### 3.2. Reset

The BlueDev+S42 is equipped with a reset button. Pressing the reset button will trigger the BlueMod+S42 module to perform a reset. The USB port is not influenced by the reset.

#### 3.3. USB Interface

The BlueDev+S42 provides an USB interface which is used to connect the evaluation board to the host and as power supply.

The USB interface is equipped with an FTDI USB to serial bridge, interfacing the serial port of the BlueMod+S42.

The serial port is a high-speed UART interface at CMOS levels and supports the following features:

- Transmission speed: 9,600 – 921,600 bps (asynchronous)
- Character representation: 8 bit, no parity, 1 stop bit (8N1)
- Hardware flow-control with RTS/CTS (active low)

For details please refer to the *BlueMod+S42 Hardware User Guide [1]*.



### 3.4. LEDs

The BlueDev+S42 provides several LEDs for functional indication.

Interface	Position	Function
LEDs	B1	Connected to GPIO[3] <sup>(1)</sup>
	C1	Connected to GPIO[2] <sup>(1)</sup>
	P1	Indicates the presence of power supply voltage

(1) Function depending on firmware support.

### 3.5. External Low Power Oscillator

The BlueDev+S42 provides an external low power crystal. This is connected to the BlueMod+S42 by default. For using alternate low power oscillator sources refer to the *schematics [3]* and the *BlueMod+S42 Hardware User Guide [1]*.

### 3.6. Connectors / Jumpers

#### 3.6.1. Jumper J1 and Jumper J2

Jumper J1 is used in conjunction with the provided demo application to enter manual test mode. J1 has to be set to position 2-3 and jumper J2 has to be set to position 1-2 to enter manual test mode.

Jumper J2 is used in conjunction with the provided demo application to enter the direct test mode (DTM). J1 and J2 have to be set to position 2-3 to enter DTM.

J1 Position	J2 Position	Function
1-2	1-2	Normal application start
2-3	1-2	Start manual test mode
2-3	2-3	Start Direct Test Mode (DTM)
1-2	2-3	Not used in demo application.

#### 3.6.2. Jumper J3

Jumper J3 is used to switch the PC DTR# pin to two different module pins.

Jumper Number	Position	Function
J3	1-2	DTR# connected to IUR-IN#
J3	2-3	DTR# connected to GPIO[4]



### 3.6.3. Jumper J4

Jumper J4 provides the possibility to disable (by closing it with a soldering point) the USB to serial bridge. With a closed jumper J4, the modules serial port is routed to Connector X3 see chapter 3.6.5.

### 3.6.4. Connector X2

Connector X2 is used as “Debug in” to connect a debugger to the BlueMod+S42 module.

### 3.6.5. Connector X3

Connector X3 is a 28 pin extension header exposing all module signals.

Pin Number	Signal	Type	Description
1	+3V0	PWR	Supply voltage output
2	+3V0	PWR	Supply voltage output
3	GND	PWR	Ground
4	GND	PWR	Ground
5	GPIO[0]	I/O	GPIO <sup>(1)</sup>
6	GPIO[1]	I/O	GPIO <sup>(1)</sup>
7	GPIO[2]	I/O	LED C1, user IO
8	GPIO[3]	I/O	LED B1, user IO
9	GPIO[4]	I/O	GPIO <sup>(1)</sup>
10	GPIO[5]	I/O	GPIO <sup>(1)</sup>
11	GPIO[6]	I/O	GPIO <sup>(1)</sup>
12	GPIO[7]	I/O	GPIO <sup>(1)</sup>
13	GPIO[8]	I/O	GPIO <sup>(1)</sup>
14	GPIO[9]	I/O	GPIO <sup>(1)</sup>
15	GPIO[10]	I/O	GPIO <sup>(1)</sup>
16	GPIO[11]	I/O	GPIO <sup>(1)</sup>
17	GPIO[12]	I/O	GPIO <sup>(1)</sup>
18	GPIO[13]	I/O	GPIO <sup>(1)</sup>





19	GPIO[14]	I/O	GPIO <sup>(1)</sup>
20	PO26_AIN0		See schematic <sup>(1)</sup>
21	PO27_AIN1		See schematic <sup>(1)</sup>
22	EXT-RES#	I-PU	User reset
23	UART-TXD <sup>(2)</sup>	O-PP	IUR data OUT
24	UART-RXD <sup>(2)</sup>	I	IUR data IN
25	UART-CTS# <sup>(2)</sup>	I	Flow control
26	UART-RTS# <sup>(2)</sup>	O-PP	Flow control
27	IUR-IN# <sup>(2)</sup>	I/O	GPIO <sup>(1)</sup>
28	IUR-OUT# <sup>(2)</sup>	I/O	GPIO <sup>(1)</sup>

PU = PullUp, PD = PullDown, PP = PushPull, I-DIS = InputBufferDisconnected

(1) Function depending on firmware support

(2) Disconnected from module when jumper J4 is open

### 3.6.6. Connector X4

Connector X4 provides the possibility to measure the supply current of the BlueMod+S42 and to power the evaluation board with an external power supply.

Pin Number	Signal
1	GND
2	ext. PWR
3	+3V0
4	+3V0-BT

### 3.6.7. Connector X5

Connector X5 could be used to insert an external low frequency clock to the nRF52832. Please open the cut off jumper J11 and J12 to disable the onboard crystal before using connector X5.

## 3.7. Current Measurement

Current measurement of the BlueMod+S42 can be performed by opening (cut off) jumper J14 and measuring the current between pin 3 and 4 of connector X4.

For measuring the minimum current the FTDI chip must be disconnected from the module. This can be achieved by closing solder jumper J4.



## 3.8. Power Supply

The three power sources are decoupled from each other by diodes connected in series. The presence of the supply voltage is indicated by LED P1.

### 3.8.1. USB Power Supply

VBUS of the USB connector X1 directly powers the USB to serial converter and via a voltage regulator the rest of the circuitry.

### 3.8.2. External Power Supply

Pin 1 and 2 of connector X4 provides the possibility to connect an external power supply (see *BlueMod+S42 Hardware User Guide [1]*).

### 3.8.3. Battery Holder

The battery holder provides the possibility to run the BlueDev+S42 without external power (via USB or external power supply) by using a 3V coin cell battery CR2032. Opening jumper J8 will disconnect the power LED P1 and thus save 1.8mA of battery current. For safety reasons there should be permanently connected no other power supply, when a battery is inserted.

## 3.9. Buzzer

The Buzzer can be used to generate alarm and other audible signals. It is connected to GPIO[5].

## 3.10. Push Button

The Push Button can be used as input for human interaction. It is connected to GPIO[1].





### 3.11. How To Interface the UART Lines on TTL Level



**NOTE:**

If you want to access the UART lines directly it is important to disable the onboard USB to serial bridge by closing jumper J4 with a soldering point.

All signals are available at connector X3 and can be connected to your application.

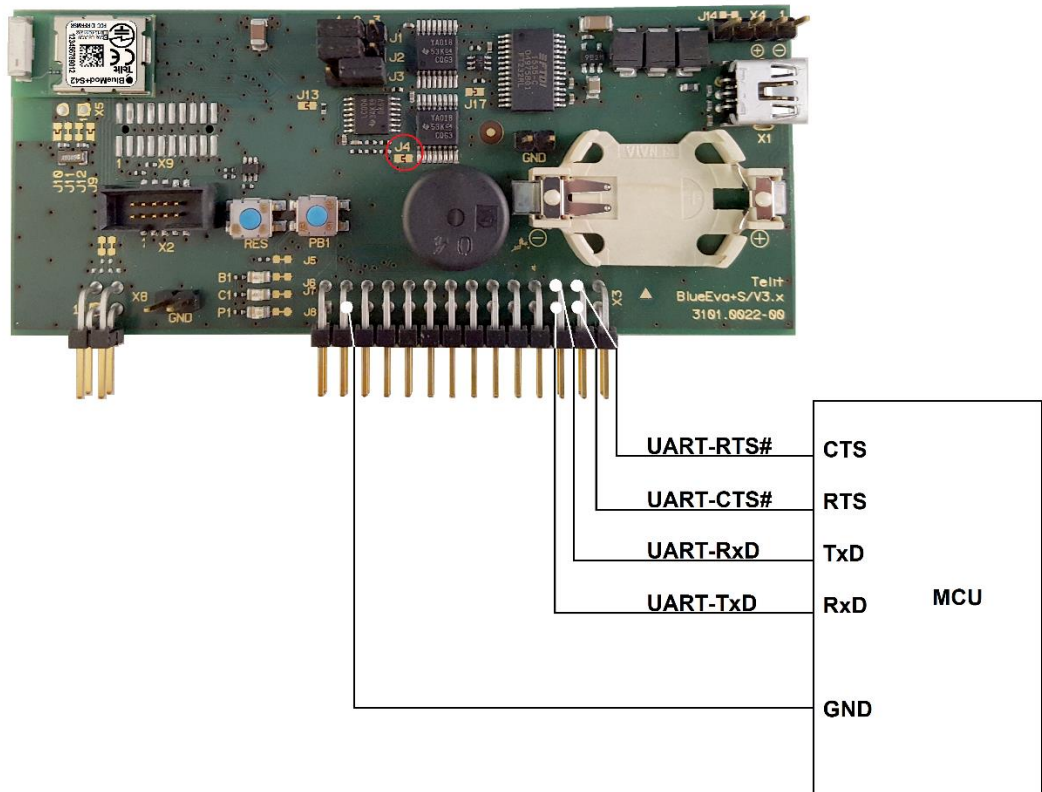

Figure 3: MCU connected to UART lines

### 3.12. Default Configuration

The BlueDev+S42 is preconfigured as described below:

Jumper Number	Position	Function
J1	1-2	Normal operation mode at start-up
J2	1-2	Normal operation mode at start-up
J3	2-3	DTR# connected to GPIO[4]

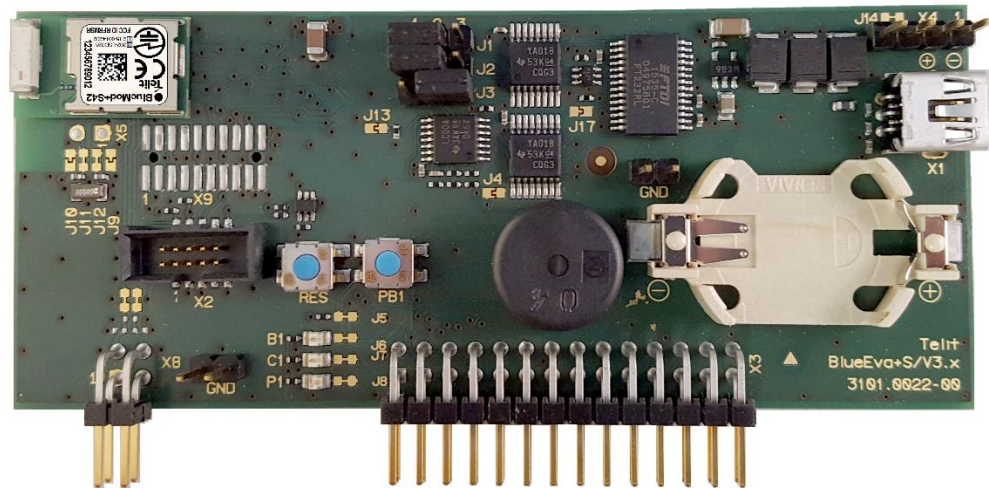

Figure 4: BlueDev+S42 default configuration



## 4. Setup

### 4.1. System Requirements

- PC with Windows® XP or higher
- 1-2 free USB ports
- Adobe Acrobat® Reader for reading the documentation
- Keil Microcontroller Development Kit for compiling the demo application
- Cortex M4 debugger hardware or Nordics nRF52 DK to be used in debugger mode connected to connector X2

### 4.2. Startup

To install the BlueDev+S42 connect it as follows.

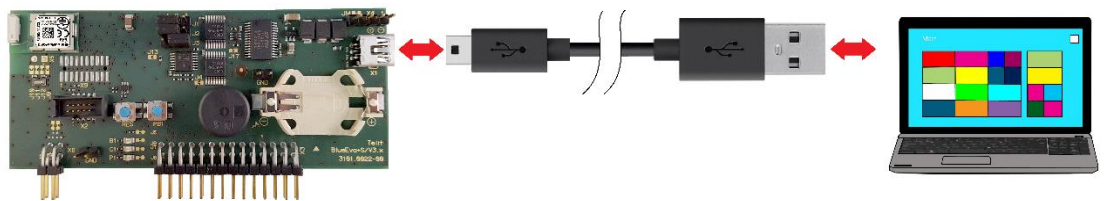

Figure 5: Connect the BlueDev+S42 to your PC

### 4.3. Installation of the BlueDev+S42 USB Driver

If required download the latest FTDI VCP USB to UART driver from:  
<http://www.ftdichip.com/Drivers/VCP.htm>

Connect the BlueDev+S42 to a free USB port of a PC and install the USB device drivers by following the instructions of the Windows® Hardware Wizard using the downloaded FTDI VCP USB to UART driver.

The USB connection is used for power supply and for UART communication to a PC over a virtual COM port. This lets you use a terminal emulation program to perform the configuration or to control the Bluetooth connection.

You may download the TeraTerm terminal program from the official open source web site:  
<https://en.osdn.jp/projects/ttssh2/releases/>





#### 4.4. Installing the Debugger

If you don't have a Cortex M4 debugger hardware in use right now, Telit recommends the use of Nordics nRF52 DK.

Please refer to the Nordic website <http://www.nordicsemi.com/eng/Products/Bluetooth-low-energy> for more information on the nRF52 DK.

#### 4.5. Connecting the nRF5 DK to the BlueDev+S42

Use the provided 9-Pin debugger cable to connect the BlueDev+S42 connector X2 with the debug out connector on the Nordic PCA10040 board.

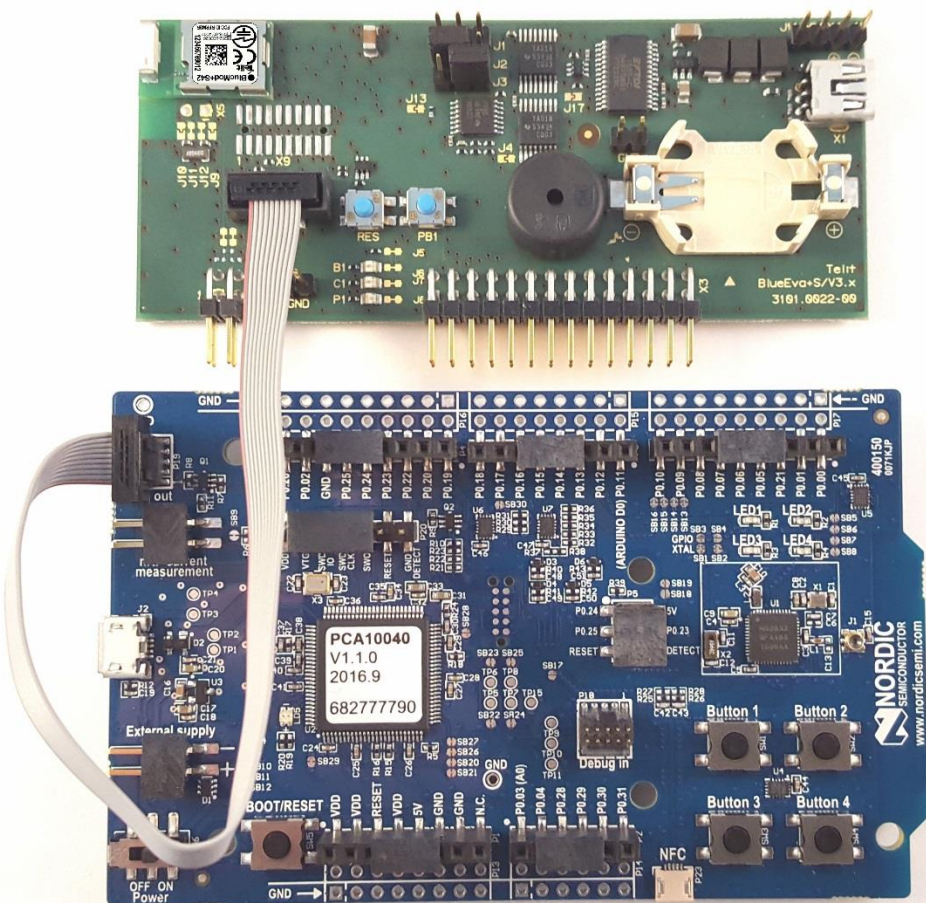

Figure 6: nRF5 DK board PCA10040 connected to BlueDev+S42 board



## 4.6. Downloading and Installing the nRF5 SDK

The Telit demo source code is based on the application template of the nRF5 SDK v11.0.0.

Please download the SDK from <http://www.nordicsemi.com/eng/Products/Bluetooth-low-energy>.

Please use the repository file nRF5\_SDK\_11.0.0\_XXXXXX.zip of the SDK.

After installing the nRF5 SDK please compile the peripheral BLE app template project with the Keil compiler to make sure that the installation succeeded. The demo is found in the directory

```
<nRF5 SDK 11.0.0 PATH>\examples\ble_peripheral\ble_app_template.
```



## 5. Usage of the BlueDev+S42

The provided BlueDev+S42 development package requires an installed nRF5 SDK v11.0.0.

Please copy the directory stoDevKit to the <nRF5 SDK 11.0.0 PATH>\external\ path. The resulting structure should be as follows:

```
<nRF5 SDK 11.0.0 PATH>\external\stoDevKit\ble_peripheral\...
```

### 5.1. Telit Demo Source Code

The provided Telit demo source code is based on the

```
<nRF5 SDK 11.0.0 PATH>\examples\ble_peripheral\ble_app_template .
```

The code and project have been modified to support the Telit manual test mode and the Direct Test Mode (DTM) defined by the Bluetooth SIG. It is also possible to assign a public Bluetooth address to be used by the firmware (through a command in manual test mode).



---

**NOTE:**

The Telit manual test mode is required if you want Telit to manufacture modules with your own firmware. Please contact Telit for more details on the manufacturing procedure.

---

### 5.2. BlueDev+S42 Software Package Structure

The directory stoDevKit contains all software provided by Telit. It uses the nRF5 SDK files to build an example project.

#### 5.2.1. The Directory “app\_template”

The directory “app\_template” contains the modified demo software sources. Please use the ble\_app\_template.uvmpw file to start the Keil IDE.

The file main.c contains the modifications which are clearly marked by “Telit specific functionality start:”.



---

**NOTE:**

Subdirectory bluemod+s42\s132\arm5\_no\_packs\RTE comprises the startup code (defines stack size etc.) which was copied here from the original app\_template\pca10040\s132\arm5\_no\_packs\RTE directory of the nRF5 SDK.

---





### 5.2.2. The Directory “common”

The directory “common” contains source code files for the Telit manual test mode and the DTM interface software.

Source file	Description
sto_testmode.c	Telit test mode implementation. GPIO control is done in this file. Starts Telit manual test mode, DTM or passes control back to the application code depending on GPIO state (jumpers J1 and J2).
sto_dtmmode.c	DTM interface code. Is called by sto_testmode.c depending on GPIO states.
sto_util.c	Contains general utility functions.
sto_xodetect.c	Contains LPO test functions.

### 5.2.3. The Directory “include”

The directory “include” contains board definition headers and required interface files for the source files from the common directory.

Source file	Description
custom_board.h	This file is required by the nRF5 SDK to import custom board specific IO mappings into the SDK.
bluemod_s42.h	Module specific definitions
bluemod_s42_eval.h	Development board specific definitions.
sto_testmode.h	Interface prototypes for sto_testmode.c.
sto_dtmmode.h	Interface prototypes for sto_dtmmode.c.
sto_util.h	Interface prototypes for sto_util.c and additional useful macro definitions.
sto_xodetect.h	Interface prototypes for sto_xodetect.c.



## 5.3. Using the Demo Application

### 5.3.1. Demo Application Advertising

After compiling and downloading the app template project to the BlueDev+S42, you can use the jumpers J1/J2 to start the normal advertising mode of the demo application.

- Set jumper J1 to 1-2 and J2 to 1-2
- Reset the module
- Use e.g. a smartphone or Nordic Master Control Panel application to scan for BLE devices
- You will find a device “**BlueMod+S42\_Template**” advertising:

```

-Discovered devices
├── BM+S42_Template (0xE64AAF2DDD3D) (-49dBm)
│   ├── RSSI: -49dBm
│   ├── Address: E64AAF2DDD3D
│   ├── Address Type: Random
│   ├── Advertising Type: Connectable
│   ├── Bonded: False
│   └── Advertising Data
│       ├── Appearance: 0x0000
│       ├── Flags: GeneralDiscoverable, BrEdrNotSupported
│       ├── ServicesCompleteListUuid16: 0x180A
│       ├── CompleteLocalName: BM+S42_Template
│       └── Scan Response Data
    
```

If connected the two services GAP and GATT are exposed:

```

Service Discovery
├── PrimaryService, Value: 00-18, Generic Access (0x1800)
│   ├── CharacteristicDeclaration, Value: 0A-03-00-00-2A, Properties: Read, Write, Characteristic UUID: 0x2A00
│   │   └── DeviceName, Value: 42-4D-2B-53-34-32-5F-54-65-6D-70-6C-61-74-65, DeviceName: BM+S42_Template
│   ├── CharacteristicDeclaration, Value: 02-05-00-01-2A, Properties: Read, Characteristic UUID: 0x2A01
│   │   └── Appearance, Value: 00-00, Appearance: 0x0000
│   └── CharacteristicDeclaration, Value: 02-07-00-04-2A, Properties: Read, Characteristic UUID: 0x2A04
│       └── SlavePreferredConnectionParameters, Value: 50-00-A0-00-00-00-90-01, MinConnInterval: 0x0050, MaxConnInterval: 0x00A0,
└── PrimaryService, Value: 01-18, Generic Attribute (0x1801)
    
```

More information on the app template behavior (LED usage ...) can be found in Nordics info center:

<http://infocenter.nordicsemi.com/index.jsp>  
search for “app\_template”



### 5.3.2. Telit Manual Test Mode

After compiling and downloading the app template project to the BlueDev+S42, you can use the jumpers J1/J2 to enter the Telit manual test mode.

- Set jumper J1 to 2-3 and J2 to 1-2
- Connect a terminal program (e.g. TeraTerm) to the COM port of the BlueDev+S42
- Set the COM port to 38400 Baud 8N1, disable hardware flow control
- Reset the module

Now the module is in Telit manual test mode:

```
#
#help
HELP
BOAD
DEVAD
VER
VERB
...
```

Please refer to [2] to get an introduction in the commands and their usage.



## 6. Document History

Revision	Date	Changes
r0	2016-08-15	First release
r1	2017-04-20	Added LPO test functions Typos corrected

