

# GPS Engine Board

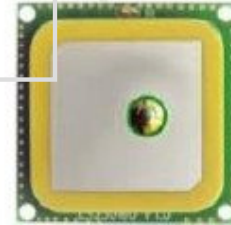

## EB-24X

EB-24X is a complete GPS sub-system with 30 x 30 mm<sup>2</sup>. Equipped with antenna, back up battery and GPS engine, it provides superior navigation performance under dynamic conditions in areas with limited sky view like urban canyons. High sensitivity up to **-158dBm** for weak signal operation without compromising accuracy. EB-24X is your best choice for embedded applications.



### Key Features :

- Compact form factor: 30 x 30 x 8.5 mm
- Lead-Free – RoHS/WEEE compliant
- Tracks 51-Channel of satellites
- Fast Position Fix
- Low power consumption
- 3.3Vdc supply voltage
- 6 pin UART port
- Build-in re-chargeable backup battery

### Applications :

- Handheld devices
- Automotive and Marine Navigation
- Automotive Navigator Tracking
- Emergency Locator
- Geographic Surveying
- Personal Positioning
- Sporting and Recreation
- Embedded applications : PDA, AVL, UMPC, PND, MP4

### PIN Definition :

Pin assignment **Low Voltage TTL version**

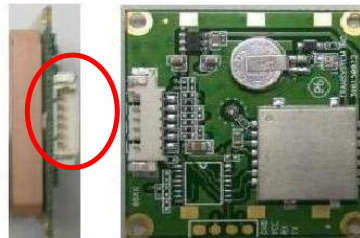
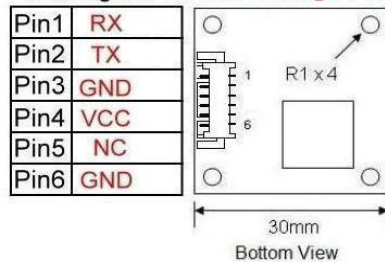

Fig1. Wafer connector

Pin assignment **RS232 version**

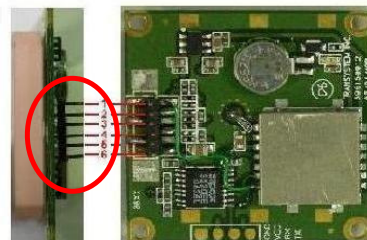
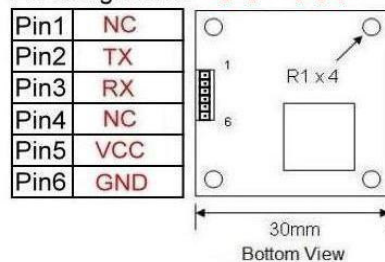
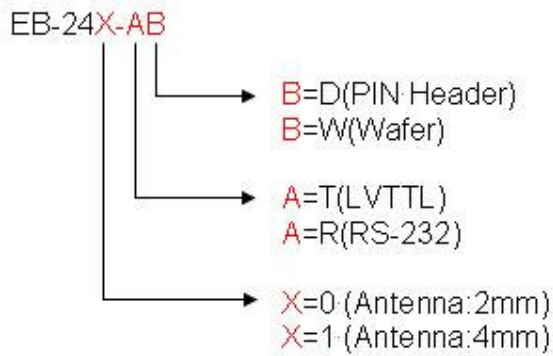

Fig2. PIN Header

Product	Antenna	Signal Level	Connector	Dimension
EB-240 TD	2mm	Low Voltage TTL	PIN Header	30 x 30 x 6.5(H) mm
EB-240 TW	2mm	Low Voltage TTL	Wafer	30 x 30 x 6.5(H) mm
EB-240 RD	2mm	RS-232	PIN Header	30 x 30 x 6.5(H) mm
EB-240 RW	2mm	RS-232	Wafer	30 x 30 x 6.5(H) mm
EB-241 TD	4mm	Low Voltage TTL	PIN Header	30 x 30 x 8.5(H) mm
EB-241 TW	4mm	Low Voltage TTL	Wafer	30 x 30 x 8.5(H) mm
EB-241 RD	4mm	RS-232	PIN Header	30 x 30 x 8.5(H) mm
EB-241 RW	4mm	RS-232	Wafer	30 x 30 x 8.5(H) mm



## Table of Contents

---

1	Introduction.....	4
1.1	Key Features.....	4
1.2	Applications .....	4
1.3	Look & Feel .....	4
2	Technical Description.....	5
2.1	Block Diagram.....	5
2.2	Pin Definition .....	7
2.3	Specification.....	8
3	Dimension and Package.....	9
3.1	Mechanical Dimension .....	9
3.2	Package .....	9
4	Other Information.....	10
4.1	General GPS Receiver User's Tips.....	10
4.2	How to avoid ESD damage to ICs.....	10

## 1 Introduction

EB-24X series is an ultra miniature 30 x 30mm<sup>2</sup> GPS engine board. It provides superior navigation performance under dynamic conditions in areas with limited sky view like urban canyons. High sensitivity up to -158dBm for weak signal operation without compromising accuracy. EB-24X series is your best choice for embedded applications.

### 1.1 Key Features

- Compact form factor: 30 x 30 x 8.5 mm
- Lead-Free – RoHS/WEEE compliant
- Tracks 51-Channel of satellites
- Fast Position Fix
- Low power consumption
- 3.3Vdc supply voltage
- 6 pin UART port
- Build-in re-chargeable backup battery

### 1.2 Applications

- Handheld devices
- Automotive and Marine Navigation
- Automotive Navigator Tracking
- Emergency Locator
- Geographic Surveying
- Personal Positioning
- Sporting and Recreation
- Embedded applications such as: PDA, DSC, Smart phone, UMPC, PND, MP4

### 1.3 Look & Feel



## 2 Technical Description

### 2.1 Block Diagram

EB-24X TD System Block Diagram

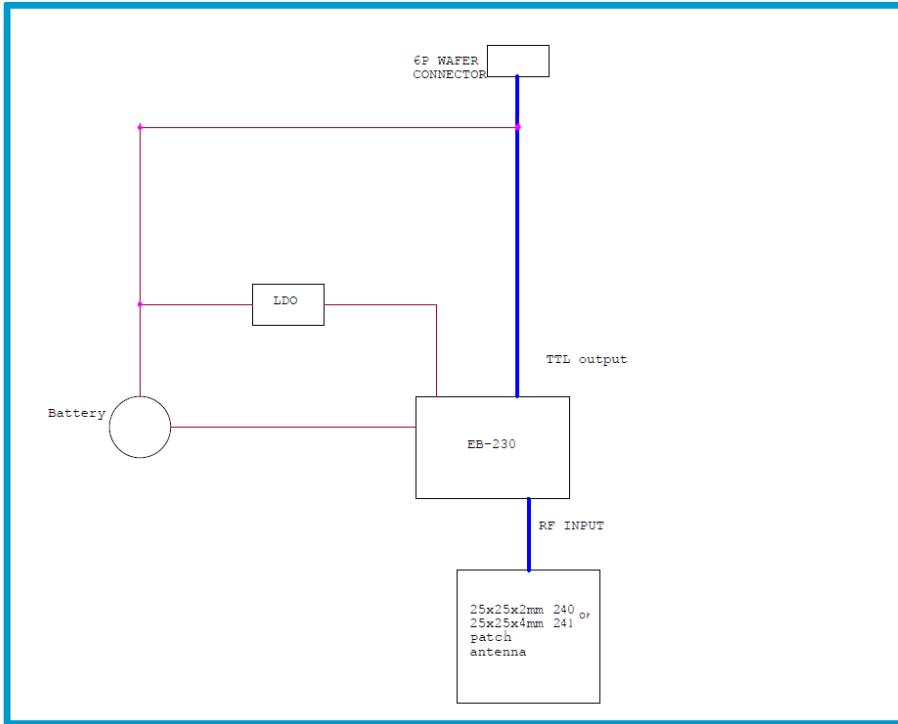

EB-24X TW System Block Diagram

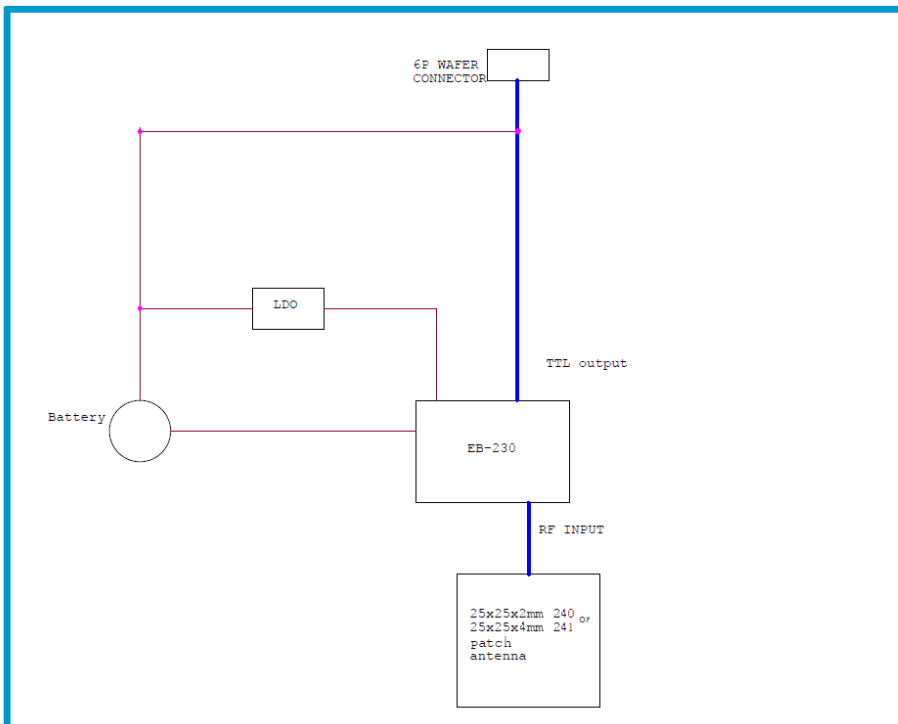

**EB-24X RW System Block Diagram**

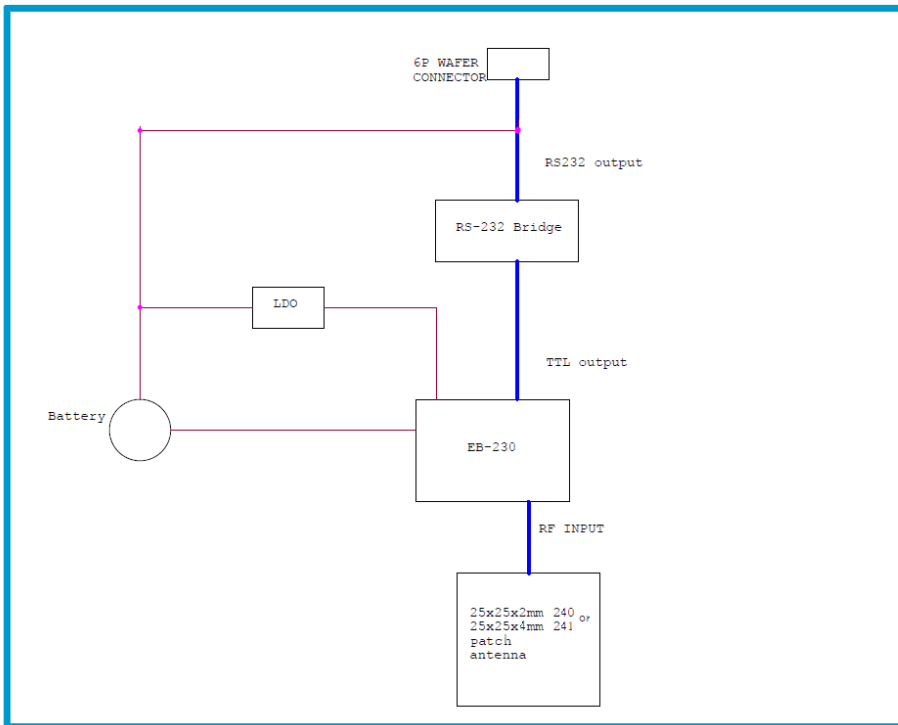

**EB-24X RD System Block Diagram**

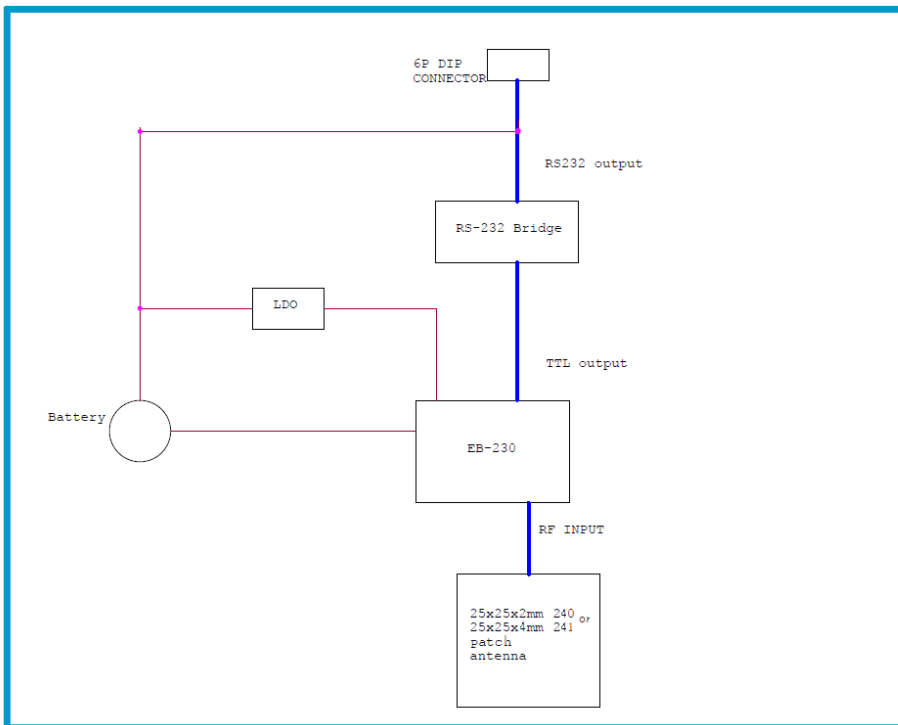

## 2.2 Pin Definition

### TTL version

Pin#	Signal Name	Type	Description
1	RX	I	GPS RX
2	TX	O	GPS TX
3	GND	P	Ground
4	VCC	P	VCC
5	NC	I	NC
6	GND	P	Ground

### RS232 version

Pin#	Signal Name	Type	Description
1	NC	I	NC
2	TX	O	GPS TX
3	RX	I	GPS RX
4	NC	I	NC
5	VCC	P	VCC
6	GND	P	Ground

P: Power    I: Input    O: Output

## 2.3 Specification

<i>Specification</i>	<i>Description</i>
General	L1 frequency, C/A code (SPS) 51 independent tracking channels
Sensitivity	-158dBm /Tracking; -146dBm /Acquisition
Update Rate	Up to 5Hz
Accuracy	Without aid: 3.0m 2D-RMS <3m CEP (50%) without SA (horizontal) DGPS (WAAS, EGNOS, MSAS, RTCM): 2.5m
Acquisition (open sky)	Cold Start: 36sec Warm Start: 33sec Hot Start: 1sec
Reacquisition	< 1sec
Dynamics	Altitude: 18000m (max.) Velocity: 515m/sec (max.) Vibration: 4G (max.)
Supply Voltage	DC 3.0~6 V
Power Consumption	30mA @ 3.30V / Tracking
Backup Battery	Build-in
NMEA Message	NMEA0183 v3.1 baud rate 4800/9600/.../57600, default 9600 Selectable Output: GGA, GLL, GSA, GSV, RMC, and VTG
Datum	Default WGS-84
Antenna	Build-in 25*25*(4 or 2)mm patch antenna, right hand circular polarization, 50ohm
Signal Level	Low Voltage TTL or RS-232
Connector	DIP or Wafer connector, pitch 1.0mm directional wire to board connector. See ordering information
Operating Temperature	-30°C to 85°C
Storage Temperature	-40°C to 85°C
Operating Humidity	≤95%, non condensing
Dimension	30 x 30 x 8.5(H) mm max, see ordering information



## 3 Dimension and Package

### 3.1 Mechanical Dimension

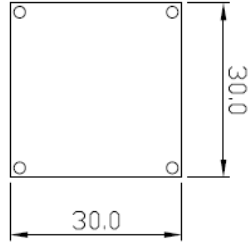

### 3.2 Package

6	8-01-96150-01	EB-24X Model label	1	
5	1-07-9615X-XX	EB-24X PCB Assy.	1	
4	8-04-22020-05	PE Bag (抗靜電膠袋)	1	
3	8-07-95100-02	Partition	2/200	
2	8-07-95100-01	Plate	3/200	
1	8-05-95100-01	Carton	1/200	
ITEM	P / N	DESCRIPTION	QTY	REMARK

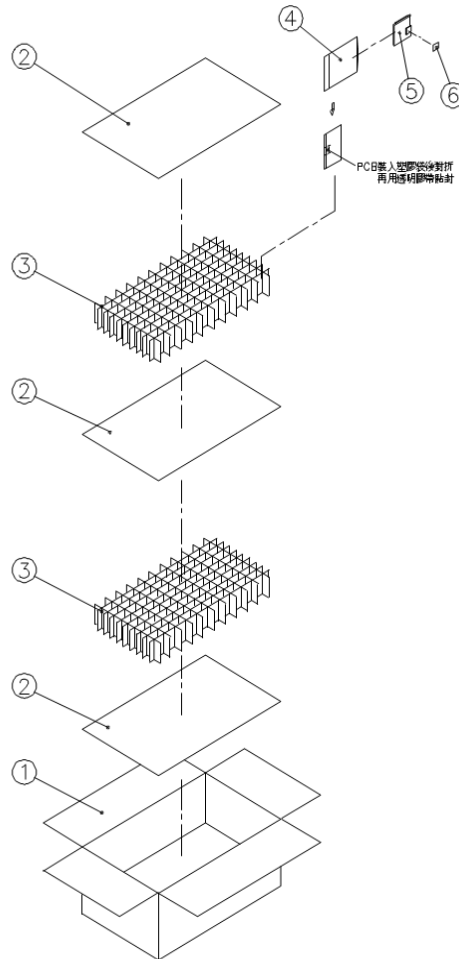

## 4 Other Information

### 4.1 General GPS Receiver User's Tips

- If the satellite signals can not be locked or experiencing receiving problem (while in urban area), following steps are suggested:
  - a) Please plug the external active antenna into GPS receiver and put the antenna outdoor or on the roof of the vehicle for better receiving performance.
  - b) Move to another open space or reposition GPS receiver toward the direction with least blockage.
  - c) Move the GPS receiver away from the interference sources.
  - d) Wait until the weather condition is improved.
- Some vehicles having heavy metallic sun protecting coating on windshields may affect signal receptions
- Driving in and around high buildings may affect signal reception.
- Driving under tunnels or in buildings may affect signal reception.
- In general, GPS receiver performs best in open space where it can see clean sky. Weather will affect GPS reception – rain & snow contribute to worsen sensitivity.
- When GPS receiver is moving, it will take longer time to get position fix. Wait for satellite signals to be locked at a fixed point when first power-on the GPS receiver to ensure quick GPS position fix.

### 4.2 How to avoid ESD damage to ICs

- Any person handling the ICs should be grounded either with a wrist strap or ESD-protective footwear used in conjunction with a conductive or static-dissipative floor or floor mat.
- The work surface where devices are placed for handling, processing, testing, etc., must, be made of static-dissipative material and be grounded to ESD ground.
- All insulator materials must either be removed from the work area or must be neutralized with an ionizer. Static-generating clothing must be covered with an ESD-protective smock.
- When ICs are being stored, transferred between operations or workstations, or shipped, they must be kept in a Faraday shield container with inside surfaces (surfaces touching the ICs) that are static-dissipative.

## Contact Information

Transystem Inc.  
No. 1-2 Li-Hsin Rd. I,  
Science-Based Industrial Park,  
Hsinchu, Taiwan, R.O.C.  
T : +886.3.578.0393  
F : +886.3.578.4111  
[www.transystem.com.tw](http://www.transystem.com.tw)  
[gps.sales@transystem.com.tw](mailto:gps.sales@transystem.com.tw)