

GPS Engine Board

EB-500/ EB-500L

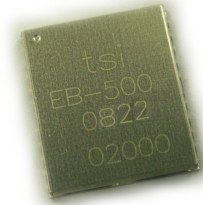

EB-500 is an ultra miniature 13 x 15 mm² GPS engine board. It provides superior navigation performance under dynamic conditions in areas with limited sky view like urban canyons. High sensitivity up to **-165dBm** for weak signal operation without compromising accuracy. EB-500 series are your best choice for embedded applications.

Key Features :

- Small form factor: 13 x 15 x 2.2 mm
- Lead-Free – RoHS/WEEE compliant
- High sensitivity -165dBm
- Tracks 66-Channel of satellites
- Fast Position Fix
- Low power consumption
- With or without LNA
- 500 with LNA
- 500L without LNA
- 500 can used passive antenna.
- 500L must be used active antenna.

Applications :

- Handheld devices
- Automotive and Marine Navigation
- Automotive Navigator Tracking
- Emergency Locator
- Geographic Surveying
- Personal Positioning
- Sporting and Recreation
- Embedded applications : PDA, DSC, Smart phone, UMPC, PND, MP4



PIN Definition :

1	RX1	GND	22
	TX1	RF_INPUT	
	PPS	GND	
	TX0	V28A	
	RX0	NC	
	GND	GND	
	GPIO [3]	GPIO [2]	
	GPS status	GPIO [8]	
	GPIO [12]	GPIO [7]	
	V28D	VIN_3V3	
11	NC	V_RTC_3V3	12

Ultimate



TRANSYSTEM INC.

An A+ supplier of RF microwave & GPS products

EB

Ver 1.6

Table of Contents

1	Introduction.....	3
1.1	Key Features.....	3
1.2	Applications	3
1.3	Look & Feel	3
2	Technical Description.....	4
2.1	Block Diagram.....	4
2.2	Pin Definition	4
2.3	Specification.....	6
3	Dimension and Package.....	7
3.1	Mechanical Dimension	7
3.2	Recommend Layout Pattern	7
3.3	Package	7
4	Application Information	8
4.1	GPS Antenna Recommendations.....	8
4.2	General GPS Receiver User's Tips.....	9
4.3	How to avoid ESD damage to ICs.....	10
4.4	SMT IR Profile	10

1 Introduction

EB-500 is an ultra miniature 13 x15mm² GPS engine board. It provides superior navigation performance under dynamic conditions in areas with limited sky view like urban canyons. High sensitivity up to -165dBm for weak signal operation without compromising accuracy. EB-500 series are your best choice for embedded applications.

1.1 Key Features

- Small form factor: 13 x 15 x 2.2 mm
- Lead-Free – RoHS/WEEE compliant
- High sensitivity -165dBm
- Tracks 66-Channel of satellites
- Fast Position Fix, 35/ 34/ 1.5s for Cold/ Warm/ Hot start
- Low power consumption

1.2 Applications

- Handheld devices
- Automotive and Marine Navigation
- Automotive Navigator Tracking
- Emergency Locator
- Geographic Surveying
- Personal Positioning
- Sporting and Recreation
- Embedded applications such as: PDA, DSC, Smart phone, UMPC, PND, MP4

1.3 Look & Feel

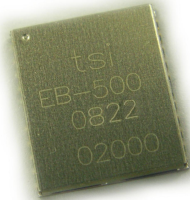

2 Technical Description

2.1 Block Diagram

EB-500 Series System Block Diagram

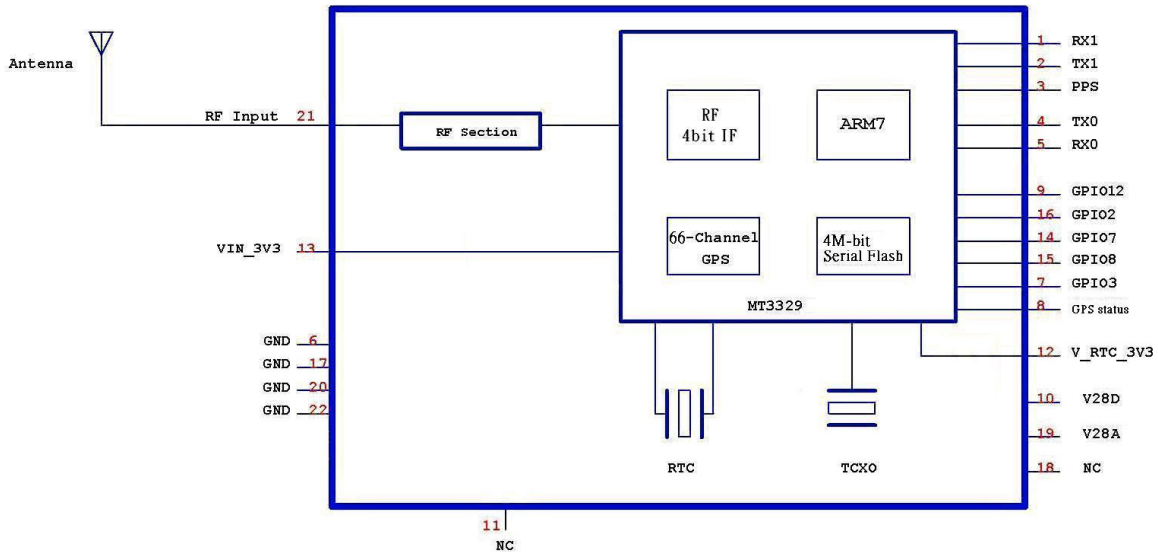

2.2 Pin Definition

Pin#	Signal Name	Type	Description
1	RX1	I	GPS RX1
2	TX1	O	GPS TX1
3	PPS	O	PPS
4	TX0	O	GPS TX0
5	RX0	I	GPS RX0
6	GND	P	Ground
7	GPIO[3]	I/O*	General input/ output
8	GPIO[15]	O	GPS status, blink when GPS has position fix
9	GPIO[12]	I/O*	General input/ output
10	V28D	P	Digital power indicator, 2.8V±2%
11	NC	I	NC
12	V_RTC_3V3	P	RTC power 2.0~4.3V Quiescent current 1.5uA max
13	VIN_3V3	P	Power Supply 3.0~4.2V DC
14	GPIO[7]	I/O*	General input / output
15	GPIO[8]	I/O*	General input / output
16	GPIO[2]	I/O*	General input / output
17	GND	P	Ground
18	NC (HRST)	NC	NC (GPS reset, active low. Internal pull high
19	V28A	P	Analog power indicator, 2.8V±2%

EB-500 Series Data Sheet

20	GND	P	Ground
21	RF Input	I	Antenna port, L1, 1575.42MHz, 50 ohm
22	GND	P	Ground

P: Power I: Input O: Output I/O*: Input or Output, Open if not used

Note : GIO current output default : 4mA

Max : 16mA

2.3 Specification

EB-500 Specifications

<i>Specification</i>	<i>Description</i>
General	L1 frequency, C/A code (SPS) 66 independent tracking channels
Sensitivity	-165dBm /Tracking; -148dBm /Acquisition
Update Rate	Up to 10Hz
Accuracy	Without aid: 3.0m 2D-RMS <3m CEP (50%) without SA (horizontal) DGPS (WAAS, EGNOS, MSAS, RTCM): 2.5m
Acquisition (open sky)	Cold start: 35sec Warm start: 34sec Hot start: 1.5sec With AGPS: <15sec
Reacquisition	< 1sec
Dynamics	Altitude: 18000m (max.) Velocity: 515m/sec (max.) Vibration: 4G (max.)
Supply Voltage	DC 3.0~4.2V
Power Consumption	EB-500: <28mA@4V (w/o Active ANT) / Tracking EB-500L: <25.5mA@4V (w/o Active ANT) / Tracking
Backup Battery	DC 2.0~4.3V (RTC Vcc)
NMEA Message	NMEA0183 v3.1 baud rate 4800/9600/.../57600, default 9600 Selectable Output: GGA, GLL, GSA, GSV, RMC, and VTG
Datum	Default WGS-84(total 219 Datum)
Antenna	External Antenna / External Active Antenna Output Voltage: 2.8 VDC
Serial Interface	UART
Operating Temperature	-40°C to 85°C
Storage Temperature	-40°C to 125°C
Operating Humidity	≤95%, non condensing
Mounting	SMT Type, 22 Pin
Dimension	13 x 15 x 2.2(H) m

3 Dimension and Package

3.1 Mechanical Dimension

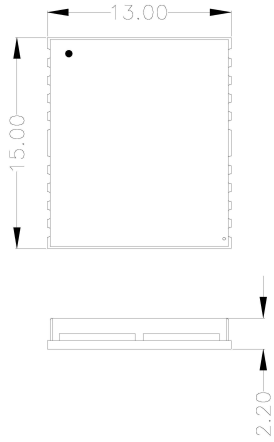

3.2 Recommend Layout Pattern

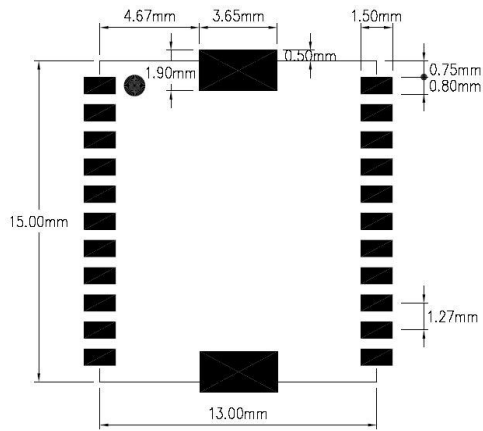

3.3 Package

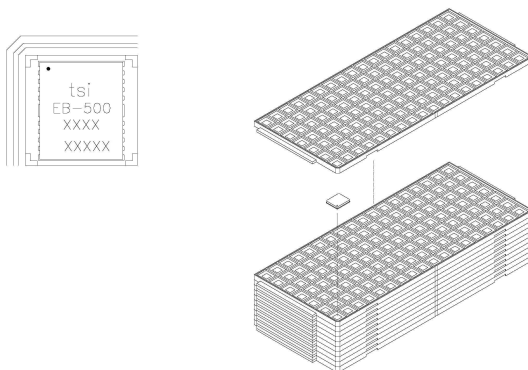

4 Application Information

4.1 GPS Antenna Recommendations

Follow below recommendations when choosing GPS antenna for EB-500 series for best system performance. Transystem also offers active antenna products for optimal performance with EB-500 series. For details, please contact your Transystem sales contact directly.

- Use active antenna that works with 2.8V power supply
- Receiving frequency $1575.42 \pm 1.032\text{MHz}$
- Polarization RHCP (right hand circular polarized)
- Output impedance = 50 Ohm
- $15\text{dB} \leq \text{LNA Gain} \leq 20\text{dB}$ (EB-500L only)
- Noise figure $\leq 2.0\text{dB}$
- Connector: surface mounted on main PCB, Ipex or MMCX Application Circuit

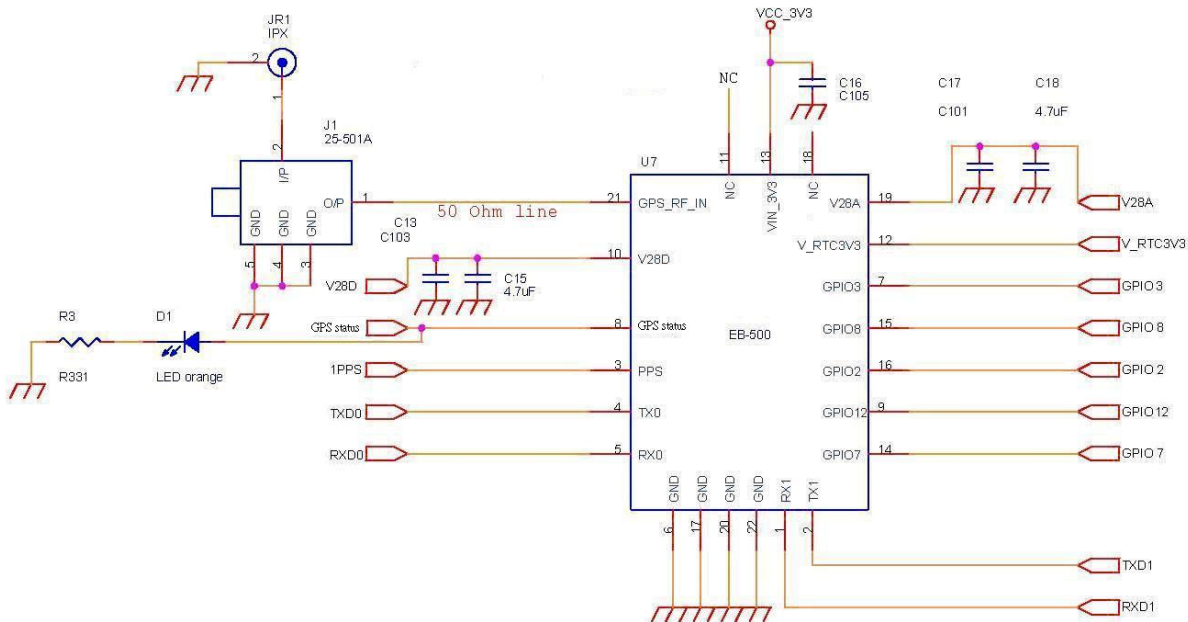

【Note1】 : GPIO[15] (pin#8) can be used as GPS position fix indicator.

【Note2】 : V_RTC_3V3 (pin#12) could connect to 2.0~4.3V DC power supply directly.

4.2 General GPS Receiver User's Tips

- If the satellite signals can not be locked or experiencing receiving problem (while in urban area), following steps are suggested:
 - a) Please plug the external active antenna into GPS receiver and put the antenna outdoor or on the roof of the vehicle for better receiving performance.
 - b) Move to another open space or reposition GPS receiver toward the direction with least blockage.
 - c) Move the GPS receiver away from the interference sources.
 - d) Wait until the weather condition is improved.
- Some vehicles having heavy metallic sun protecting coating on windshields may affect signal receptions
- Driving in and around high buildings may affect signal reception.
- Driving under tunnels or in buildings may affect signal reception.
- In general, GPS receiver performs best in open space where it can see clean sky. Weather will affect GPS reception – rain & snow contribute to worsen sensitivity.
- When GPS receiver is moving, it will take longer time to get position fix. Wait for satellite signals to be locked at a fixed point when first power-on the GPS receiver to ensure quick GPS position fix.

4.3 How to avoid ESD damage to ICs

- Any person handling the ICs should be grounded either with a wrist strap or ESD-protective footwear used in conjunction with a conductive or static-dissipative floor or floor mat.
- The work surface where devices are placed for handling, processing, testing, etc., must, be made of static-dissipative material and be grounded to ESD ground.
- All insulator materials must either be removed from the work area or must be neutralized with an ionizer. Static-generating clothing must be covered with an ESD-protective smock.
- When ICs are being stored, transferred between operations or workstations, or shipped, they must be kept in a Faraday shield container with inside surfaces (surfaces touching the ICs) that are static-dissipative.

4.4 SMT IR Profile

Average ramp-up rate (217C to peak): 3 oC /sec. max.

Preheat : 150~200 oC · 60~180 seconds

Temperature maintained above 217 oC : 60~150 seconds

Time within 5 oC of actual peak temperature: 20 ~ 40 sec.

Peak temperature : 250+0/-5 oC

Ramp-down rate : 6 oC /sec. max.

Time 25 oC to peak temperature : 8 minutes max.

Cycle interval : 5 min

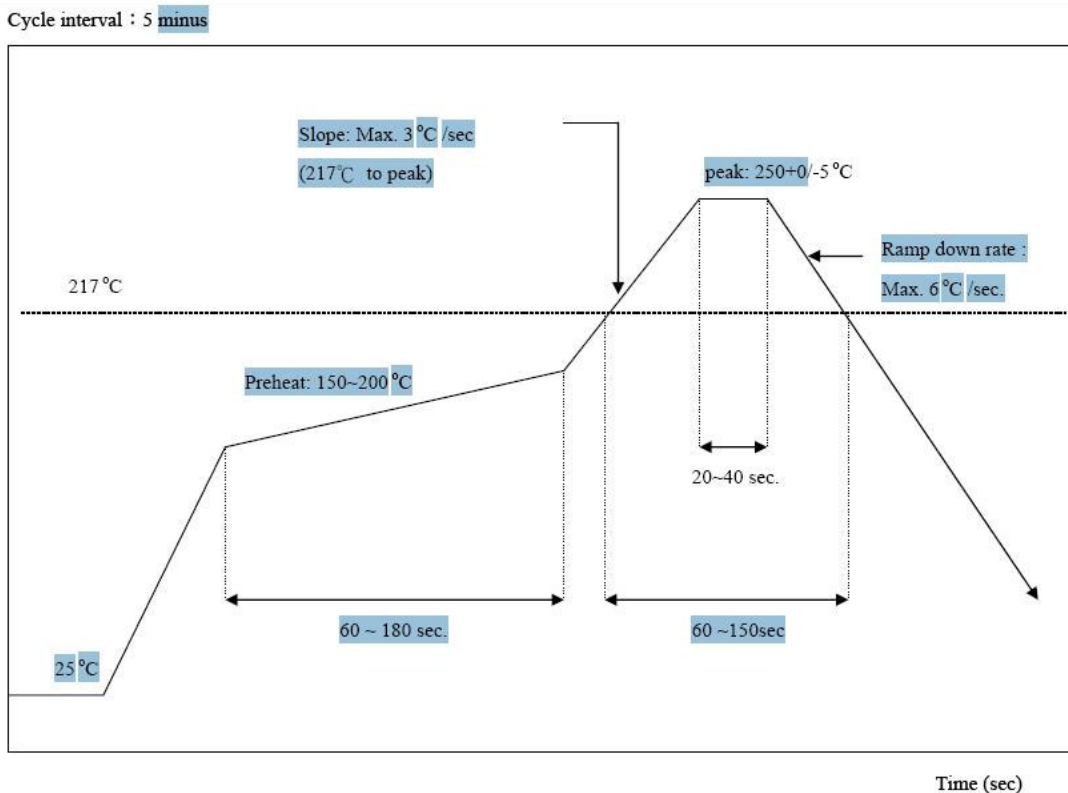

Contact Information

Transystem Inc.
No. 1-2 Li-Hsin Rd. I,
Science-Based Industrial Park,
Hsinchu, Taiwan, R.O.C.
T : +886.3.578.0393
F : +886.3.578.4111
www.transystem.com.tw
sales@transystem.com.tw