

GPS Engine Board

EB-800A / EB-800AL

EB-800A is a miniature 13 x15 mm² **GPS / Glonass** engine that is capable of receiving both GPS and Glonass signal with single RF input and high receiving sensitivity.

With up to **-165dBm** superior tracking sensitivity, the GPS + Glonass dual system EB-800A enables better satellite coverage and superior position accuracy for your navigation need under dynamic conditions in areas with limited sky view like urban canyons.

EB-800A is pin compatible with TSI's popular EB-500, it provides best migration path for your embedded applications.

Key Features :

- Small form factor: 13 x 15 x 2.2 mm
- Support GPS + Glonass dual system
- Lead-Free – RoHS/WEEE compliant
- High sensitivity -165dBm
- Tracks 99-Channel of satellites
- Support multi-GNSS including. QZSS, SBAS
- WAAS/EGNOS/MSAS/GAGAN supported
- RTCM ready
- AlwaysLocate™ location awareness technology
- EPO™ / HotStill™ orbit prediction
- EASY™ self-generated orbit prediction
- Fast Position Fix
- Ultra low power consumption
- FCC E911 compliance and A-GPS support
- Backward compatible with EB-500
- EB-800A w/ LNA, EB-800AL w/o LNA
- EB-800A can used passive antenna
- EB-800AL must be active antenna

Applications :

- Handheld devices
- Automotive and Marine Navigation
- Automotive Navigator Tracking
- Emergency Locator
- Geographic Surveying
- Personal Positioning
- Sporting and Recreation
- Embedded applications : PDA, DSC, Smart phone, UMPC, PND, MP4



PIN Definition :

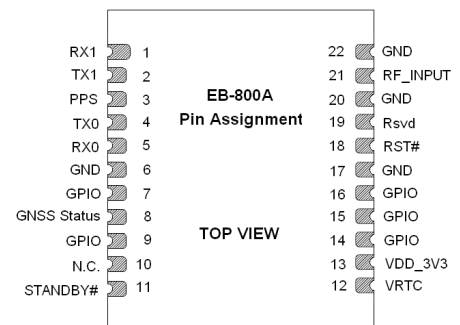

Ultimate



TRANSYSTEM INC.

An A+ supplier of RF microwave & GPS products

EB

Ver 0.5

Revision History

Rev.	Date	Description
0.5	03-06-2013	Add EB-800AL info
0.4	11-28-2012	Modify 2.2 Pin Definition table
0.3	11-21-2012	Modify standby current and supply voltage data. Remove quiescent current data.
0.2	09-25-2012	Update V_RTC Quiescent Current info
0.1	09-19-2012	Initial draft
	MM-DD-YYYY	



EB-800A series are ESD (electrostatic discharge) sensitive device and may be damaged with ESD or spike voltage. Please handle with care to avoid permanent malfunction or performance degradation.

Use of GPS / GLONASS Data and Services at the User's own risk

The GPS / Glonass data and navigation services providers, system makers and integrated circuit manufacturers ("Providers") hereby disclaim any and all guarantees, representations or warranties with respect to the Global Positioning Systems (GPS) data or the GPS / Glonass services provided herein, either expressed or implied, including but not limited to, the effectiveness, completeness, accuracy, fitness for a particular purpose or the reliability of the GPS / Glonass data or services.

The GPS / Glonass data or services are not to be used for safety of life applications or for any other application in which the accuracy or reliability of the GPS / Glonass data or services could create a situation where personal injury or death may occur. Any use therewith are at the user's own risk. The Providers specifically disclaims any and all liability, including without limitation, indirect, consequential and incidental damages, that may arise in any way from the use of or reliance on the GPS / Glonass data or services, as well as claims or damages based on the contravention of patents, copyrights, mask work and/or other intellectual property rights.

No part of this document may be copied, distributed, utilized, and transmitted in any form or by any means without expressed authorization of all Providers. The GPS / Glonass data and services are in part or in all subject to patent, copyright, trade secret and other intellectual property rights and protection worldwide.

Transystem Inc. reserves the right to make change to specifications and product description without prior notification.

© 2012 TRANSYSTEM INC. all rights reserved.

Table of Contents

1	Introduction.....	5
1.1	Key Features.....	5
1.2	Applications.....	5
1.3	Look & Feel.....	5
2	Technical Description.....	6
2.1	Block Diagram.....	6
2.2	Pin Definition.....	6
2.3	Specification.....	8
3	Electrical Characteristics	9
3.1	Absolute maximum ratings.....	9
3.2	Operating Conditions	9
3.3	DC Electrical Characteristics.....	9
4	Serial Port Interface.....	10
4.1	Protocol.....	10
4.1.1	NMEA Protocol.....	10
5	Dimension and Package.....	11
5.1	Mechanical Dimension.....	11
5.2	Recommend Layout Pattern	11
5.3	PIN Coordinates.....	12
5.4	Package.....	12
6	Recommended IR Profile.....	13
7	Application Information	14
7.1	GPS / Glonass Antenna Recommendations	14
7.2	Application Circuit	14
7.3	PPS pin.....	15
7.4	Reset Signal.....	15
7.5	Battery Back-up	15
7.6	General GPS / Glonass Receiver User's Tips.....	16
8	Quality and Reliability	17
8.1	Environmental Conditions	17
8.2	How to avoid ESD damage to module	17

1 Introduction

EB-800A is an ultra miniature 13 x15 x 2.2mm GPS / Glonass engine board. It provides superior navigation performance under dynamic conditions in areas with limited sky view like urban canyons. High sensitivity up to -165dBm for weak signal operation without compromising accuracy. EB-800A series are your best choice for embedded applications.

1.1 Key Features

- Small form factor: 13 x 15 x 2.2 mm
- Lead-Free – RoHS/WEEE compliant
- High sensitivity -165dBm
- Tracks 99-Channel of satellites
- Fast Position Fix, 35/ 34/ 1.5s for Cold/ Warm/ Hot start
- Low power consumption

1.2 Applications

- Handheld devices
- Automotive and Marine Navigation
- Automotive Navigator Tracking
- Emergency Locator
- Geographic Surveying
- Personal Positioning
- Sporting and Recreation
- Embedded applications such as: PDA, DSC, Smart phone, UMPC, PND, MP4

1.3 Look & Feel



2 Technical Description

2.1 Block Diagram

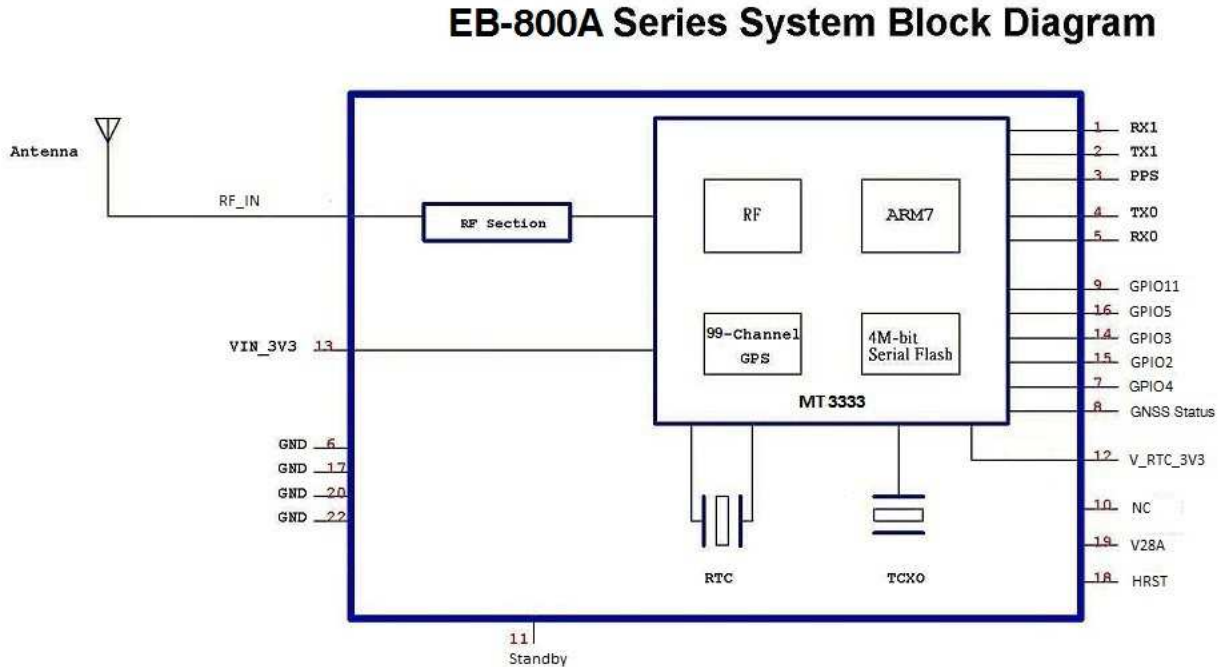

2.2 Pin Definition

Pin#	Signal Name	Type	Description
1	RX1	I	UART port 1 input
2	TX1	O	UART port 1 output
3	PPS	O	Pulse per second output when GPS has position fix, 10% duty cycle
4	TX0	O	GPS TX0
5	RX0	I	GPS RX0
6	GND	P	Ground
7	GPIO[4]	I/O*	General input/ output, leave open if not used
8	GNSS status	O	GNSS status, blink when GPS / Glonass has position fix
9	GPIO[11]	I/O*	General input/ output, leave open if not used
10	NC	I	NC
11	Standby	I	Falling edge trigger. Back to High for normal operation. Leave open if not used
12	V_RTC_3V3	P	RTC power 2.0~4.3V Quiescent current 2.0uA max
13	VIN_3V3	P	Power Supply 2.8~4.3V DC
14	GPIO[3]	I/O*	General input/ output, leave open if not used
15	GPIO[2]	I/O*	General input/ output, leave open if not used
16	GPIO[5]	I/O*	General input/ output, leave open if not used
17	GND	P	Ground

EB-800A Series Data Sheet

18	HRST	I	Module reset, active low. Internal pull high leave open if not used
19	V28A	P	Analog power indicator, 2.8V±2%
20	GND	P	Ground
21	RF Input	I	Antenna port, L1, 1575.42MHz, 50 ohm
22	GND	P	Ground

P: Power I: Input O: Output I/O*: Input or Output, Open if not used

Note : GIO current output default : 4mA, Max: 16mA

2.3 Specification

Item	Description
General	L1 frequency, C/A code (SPS) 99 independent tracking channels
Sensitivity	-165dBm /Tracking; -148dBm /Acquisition
Update Rate	Up to 10Hz
Accuracy	<3m CEP (50%) without SA (horizontal) DGPS (WAAS, EGNOS, MSAS, RTCM): 2.5m
Acquisition (open sky)	Cold Start: <35sec Warm Start: <34sec Hot Start: <1.5sec
Reacquisition	< 1sec
Dynamics	Altitude : 18000m (max.) Velocity : 515m/sec (max.) Vibration : 4G (max.)
Supply Voltage	DC 2.8~4.3 V
Power Consumption	EB-800A: < 22 mA @ 3.3V (w/o Active ANT) / Tracking EB-800AL: < 20 mA @ 3.3V (w/o Active ANT) / Tracking
Backup Battery	DC 2~4.3V, 20 uA@3.3V typical
NMEA Message	NMEA0183 v3.1 baud rate 4800/9600/.../115200, default 9600 Selectable Output: GGA, GLL, GSA, GSV, RMC, and VTG
Datum	Default WGS-84
Antenna	External Active Antenna Output Voltage: 2.8 VDC or Passive Antenna
Serial Interface	UART
Operating Temp.	-40°C to 85°C
Storage Temp.	-40°C to 85°C
Operating Humidity	≤95%, non condensing
Mounting	SMT Type, 22 Pin
Dimension	13 x 15 x 2.2(H) mm

3 Electrical Characteristics

3.1 Absolute maximum ratings

Symbol	Parameter	Min	Max	Unit
Vcc	power supply	-0.3	+4.3	V
Vin	voltage to any pin	-0.3	+3.6	V
Iov	input current on any pin	-10	10	mA
Tst	storage temperature	-40	85	°C
Iant	antenna supply current		30	mA

Table 3-1 Absolute maximum ratings

Note:

- (1) Stresses beyond absolute maximum ratings may cause permanent damage to the device.
- (2) Exposure to absolute maximum rating conditions for extended period may affect device reliability.

3.2 Operating Conditions

Pin	Description	Min	Typical	Max	Unit
12	V_RTC_3V3	2.0	4.0	4.3	V
	Tracking Current (2)		43		uA
13	VIN_3V3	2.8	3.3	4.3	V
	Peak Acquisition Current (1)			26	mA
	Tracking Current (2)		22		mA
	Standby Current		0.3		mA

Table 3-2 Operating Conditions

Note:

- (1) Peak acquisition current is the maximum current with passive antenna.
- (2) Tracking current is the average current with passive antenna includes tracking and post acquisition portion.

3.3 DC Electrical Characteristics

Symbol	Parameter	Min	Max	Unit
1PPS, GNSS Status, TX1, TX0, GPIO 2,3,4,5	Voh	0.85*VDDIO		V
	Vol		0.15*VDDIO	V
RX1, RX0, STANDBY#, HRST#	Vih	0.75*VDDIO	VDDIO+0.3	V
	Vil	-0.3	0.25*VDDIO	V

Table 3-3 DC Electrical characteristics

Note:

- (1) The typical of VDDIO is 2.8V

4 Serial Port Interface

EB-800A provides 2-wire digital UART port for communication of GPS / Glonass position data using NMEA protocol or MTK extension protocol. UART port is capable of 4800 to 115200 baud rate.

4.1 Protocol

EB-800A is default to support standard NMEA-0183 protocol. In addition, a series of MTK extensions (PMTK messages) have been developed that can be used to provide extended capabilities common to many applications. Please refer to “GPS Engine Board UART Port Command” for detailed command information.

4.1.1 NMEA Protocol

EB-800A is capable of supporting following NMEA formats:

NMEA Prefix	Format	Direction
\$GPGGA	GPS fix data	Out
\$GPGLL	Geographic position Latitude / Longitude	Out
\$GNGSA	GNSS DOP and active satellites	Out
\$GPGSV	GPS Satellites in view	Out
\$GPRMC	Recommended minimum specific GNSS data	Out
\$GPVTG	Velocity and track over ground	Out
\$GPZDA	Date and time	Out
\$GGLSV	GLONASS Satellites in view	Out

5 Dimension and Package

5.1 Mechanical Dimension

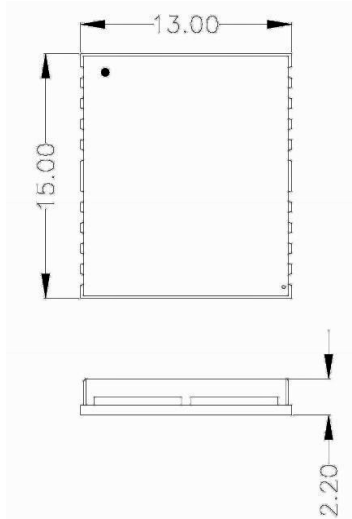

5.2 Recommend Layout Pattern

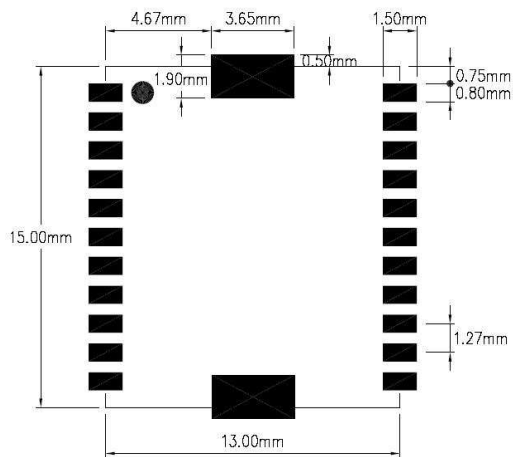

5.3 PIN Coordinates

Unit:mm

Pin #	X	Y	Pin #	X	Y
1	0.00	0.00	12	13.0	12.7
2	0.00	1.27	13	13.0	11.43
3	0.00	2.54	14	13.0	10.16
4	0.00	3.81	15	13.0	8.89
5	0.00	5.08	16	13.0	7.62
6	0.00	6.35	17	13.0	6.35
7	0.00	7.62	18	13.0	5.08
8	0.00	8.89	19	13.0	3.81
9	0.00	10.16	20	13.0	2.54
10	0.00	11.43	21	13.0	1.27
11	0.00	12.7	22	13.0	0.00

5.4 Package

EB-800A GPS modules come in tray package suitable for pick and place machines. Each tray contains total 96 pieces of EB-800A and maximum 10 trays are stacked together before sealed in ESD protective vacuum dry pack to provide protection against moisture and ESD during storage and shipment.

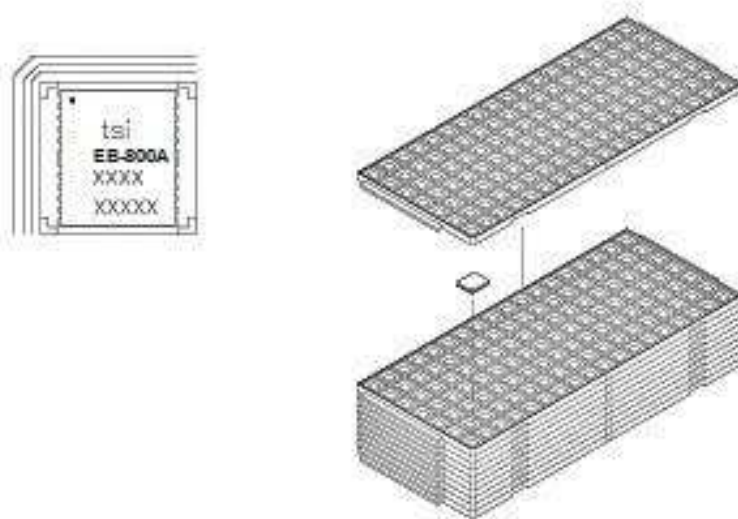

6 Recommended IR Profile

Follow below IR profile for reflow during SMT assembly for EB-800A.

Cycle interval : 5 **minus**

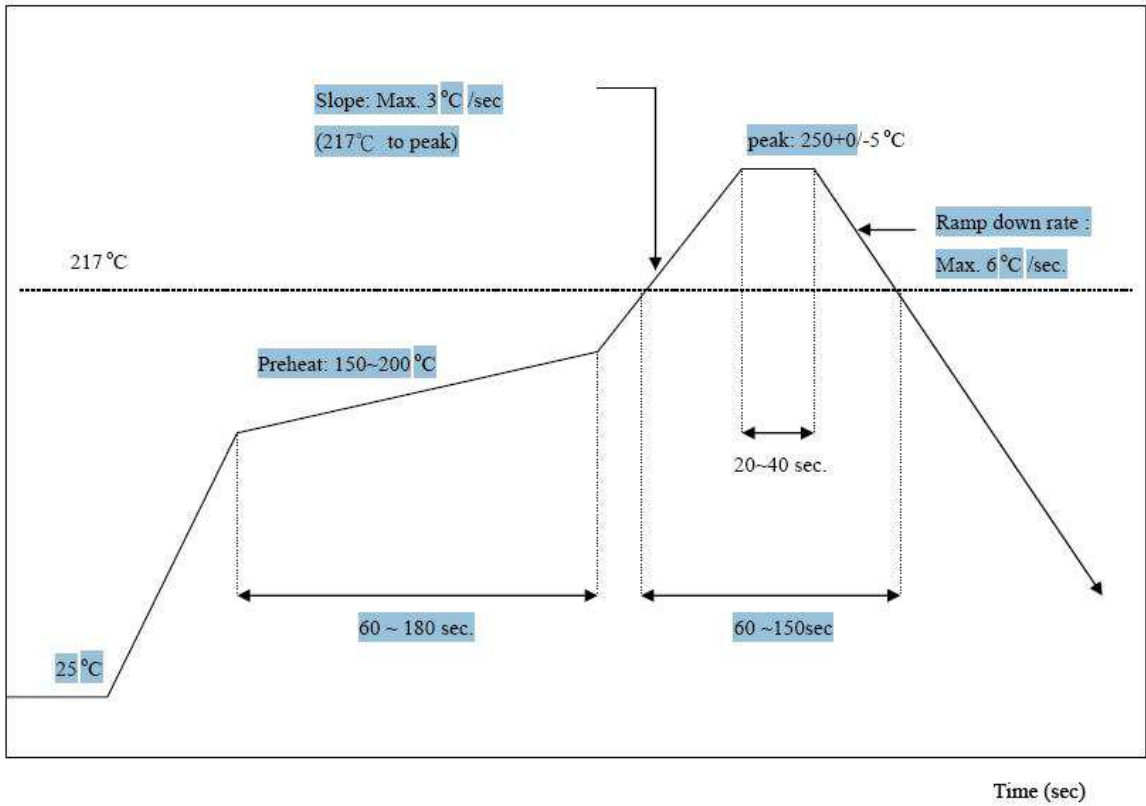

7 Application Information

7.1 GPS / Glonass Antenna Recommendations

Follow below recommendations when choosing GPS / Glonass antenna for EB-800A series for best system performance. Transystem also offers active antenna products for optimal performance with EB-800A series. For details, please contact your Transystem sales contact directly.

- Use active antenna that works with 2.8V power supply
- Receiving frequency 1573MHz ~ 1610MHz
- Polarization RHCP (right hand circular polarized)
- Output impedance = 50 Ohm
- $15\text{dB} \leq \text{LNA Gain} \leq 20\text{dB}$ (for EB-800AL only)
- Noise figure $\leq 1.5\text{dB}$
- Connector: surface mounted on main PCB, Ipex or MMCX

7.2 Application Circuit

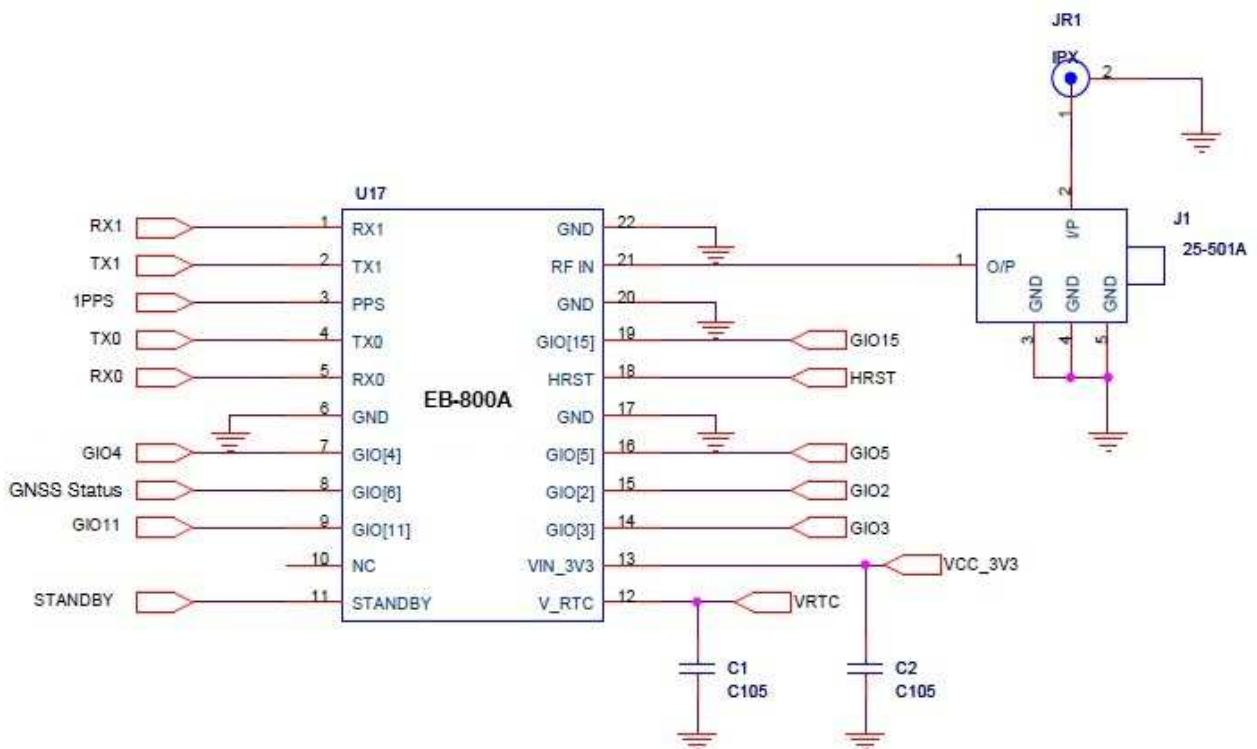

【Note1】 : GPIO[6] (pin#8) can be used as GPS / Glonass position fix indicator.

【Note2】 : VRTC_3V3 (pin#12) could connect to 3.3V DC power supply or battery directly.

7.3 PPS pin

EB-800A also provides accurate timing information due to the synchronized atomic clocks in the GPS / Glonass satellites. In addition to the current date and time is transmitted in NMEA sentences (UTC), an accurate timing signal is provided via the PPS pin (pin #3) of the EB-800A GPS / Glonass receiver.

Under good signal conditions the 1PPS signal comes between 620ns and 710ns after the full GPS system second which is accurately (around 10ns) synchronized to UTC. Therefore the 1 second clock can be derived and maintained within around 90ns under good signal conditions.

The 1PPS signal accuracy directly relates to the position accuracy. The GPS / Glonass signals travel at the speed of light, therefore a position inaccuracy directly translates into 1PPS inaccuracies.

10 m position deviation \approx 33 ns 1PPS deviation (typically)

100 m position deviation \approx 333 ns 1PPS deviation (typically)

The 1PPS signal is provided on an "as it is" basis with no accuracy specification.

7.4 Reset Signal

The HRST (pin #18) can be used to reset the EB-800A module. Resetting the module will result in a restart of the complete firmware.

The EB-800A is equipped with a voltage monitoring circuit that generates a proper power-on reset signal at the appropriate threshold and delay. Usually there is no need to deal with the reset input externally, thus the general advice is to leave this pin open.

7.5 Battery Back-up

VRTC_3V3 input (pin #12) provides back-up power for the RTC and SRAM of the GPS / Glonass receiver module. Typical quiescent current 2uA allows the use of a separate battery or a "Supercap". The VRTC_3V3 pin draws 20uA typical under normal operation

7.6 General GPS / Glonass Receiver User's Tips

- If the satellite signals can not be locked or experiencing receiving problem (while in urban area), following steps are suggested:
 - a) Please plug the external active antenna into GPS / Glonass receiver and put the antenna outdoor or on the roof of the vehicle for better receiving performance.
 - b) Move to another open space or reposition GPS / Glonass receiver toward the direction with least blockage.
 - c) Move the GPS / Glonass receiver away from the interference sources.
 - d) Wait until the weather condition is improved.
- Some vehicles having heavy metallic sun protecting coating on windshields may affect signal receptions
- Driving in and around high buildings may affect signal reception.
- Driving under tunnels or in buildings may affect signal reception.
- In general, GPS / Glonass receiver performs best in open space where it can see clean sky. Weather will affect GPS / Glonass reception – rain & snow contribute to worsen sensitivity.
- When GPS / Glonass receiver is moving, it will take longer time to get position fix. Wait for satellite signals to be locked at a fixed point when first power-on the GPS / Glonass receiver to ensure quick GPS / Glonass position fix.

8 Quality and Reliability

Each module is electrically tested prior to packing and shipping to ensure state of the art product quality and best GPS / Glonass receiver performance and accuracy.

8.1 Environmental Conditions

Operating temperature	-40 ~ +85°C
Operating humidity	Max. 95%, non-condensing
MSL JEDEC (Moisture Sensitivity Level)	3
Storage temperature	-40 ~ +85°C
Storage	12 months in original package.

8.2 How to avoid ESD damage to module

- Any person handling the module should be grounded either with a wrist strap or ESD-protective footwear used in conjunction with a conductive or static-dissipative floor or floor mat.
- The work surface where devices are placed for handling, processing, testing, etc., must, be made of static-dissipative material and be grounded to ESD ground.
- All insulator materials must either be removed from the work area or must be neutralized with an ionizer. Static-generating clothing must be covered with an ESD-protective smock.
- When module are being stored, transferred between operations or workstations, or shipped, they must be kept in a Faraday shield container with inside surfaces (surfaces touching the module) that are static-dissipative.

Contact Information

Transystem Inc.
No. 1-2 Li-Hsin Rd. I,
Science-Based Industrial Park,
Hsinchu, Taiwan, R.O.C.
T : +886.3.578.0393
F : +886.3.578.4111
www.transystem.com.tw
sales@transystem.com.tw