



Jupiter 30 xLP

Extra Low Power 20-channel high sensitivity receiver module

Key Features

- 30% less power consumption than the previous Jupiter 30
- ultra-high sensitivity 20-channel GPS receiver with faster times to fix under all conditions
- 200 000 effective correlators allows for improved indoor fixes and tracking capability
- Support uploading of live Ephemeris providing <1 s hot start performance
- Selectable User Profiles with ability to save configuration to Flash
- 0.5 PPM TCXO for optimal performance
- integral LNA with low power control
- user selectable SBAS (WAAS, EGNOS and MSAS) support
- environmentally friendly RoHS compliance

Navman's Jupiter 30 xLP has been designed without compromise to give the ultimate in high sensitivity GPS performance at a very competitive price. Jupiter 30 xLP acquires GPS position faster under low signal conditions than other available GPS engines. Tracking continues in areas of dense foliage or built-up inner city environments and even indoors down to -159 dBm.

Using the new and highly integrated GSC3e/LPx from SiRF and carefully selected key components including TCXO, LNA and Flash, the Jupiter 30 xLP offers faster GPS acquisition, 30% less power consumption, a wider operating voltage range and greater noise rejection capability than leading competitors products using a similar architecture.

Sharing the same form factor and extended software messaging as the Jupiter 30, the new Jupiter 30 xLP offers a risk free upgrade path for any customer with less power consumption.

Module architecture

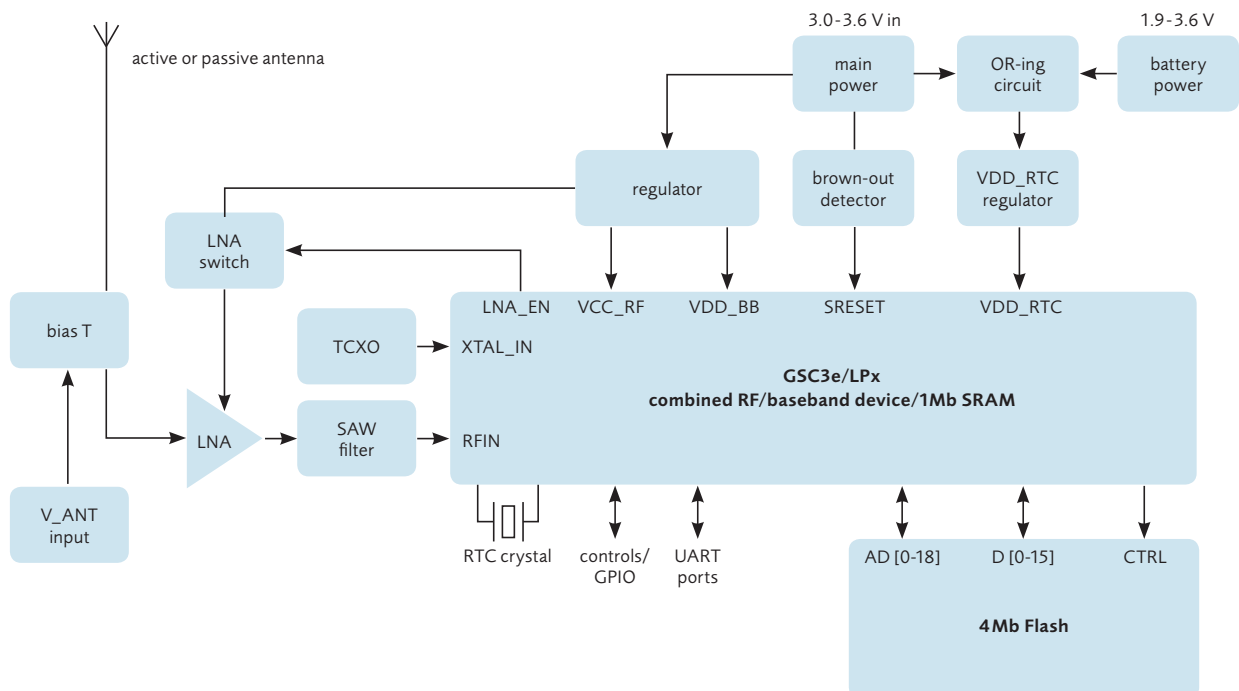

Product specifications

Receiver architecture

- 20-channel, 200000 effective correlators, L1 1575.42 MHz
- C/A code (1.023 MHz chip rate)
- code-plus-carrier tracking (carrier-aided tracking)
- velocity, up to 500 m/s
- acceleration, up to 4G

Tracking capability

- 20 satellites simultaneously

Accuracy

- horizontal accuracy: 2.5 m (CEP), 5.5 m 2dRMS
- velocity accuracy: speed < 0.01 m/s; heading < 0.01°

Acquisition performance

Mode	@ -125 dBm	
	Typical	90%
hot start TTFF	500ms	<1 s
warm start TTFF	31 s	36 s
cold start TTFF	33 s	38 s

Antenna input

- integral LNA for use with passive antenna
- active antenna powered through receiver (50 mA max at 12 VDC max)

Datums

- supports selection of datum, default: WGS-84

Environmental

- operating temperature: -40°C to +85°C
- humidity: up to 95% non-condensing
- altitude: -305 m to 18000 m

Compliance

- Automotive Standard TS16949
- EMC: FCC – Part 15, class B
- EN: 55022, class B
- RoHS

Physical

- dimensions: 25.4 x 25.4 x 3.0 mm
- weight: < 4g

On-board filtering

- L1 -75 MHz, -30 dB
- L1 +50 MHz, -20 dB

Data interfaces

- two serial ports available
- 5 GPIOs
- CMOS-level (3.3 VDC)
- selectable baud rates
- selected NMEA-0183/SiRF binary messages: latitude, longitude, elevation, velocity, heading, time, satellite tracking status, command/control messages
- SiRF binary interface: raw data

Electrical

- input power range: 3.0 to 3.6 VDC
- battery backup current: 5 to 6 µA (typ) for 1.9 to 3.3 VDC (SRAM and RTC)

Mode	Power consumption	
	@ 3 V	@ 3.3 V
average sustained power (after 1st solution)	<82 mW	<95 mW

Connectors

- data/power/RF through surface mount pads

Related documents

- Data sheet LA000576
- Integrator's manual LA000577
- Development Kit guide LA000578

Ordering information

- AA003051-G Jupiter 30 xLP (standard)
- AA003052-G Jupiter 30 xLP on adaptor board
- AA003053-G Jupiter 30 xLP Development Kit

Contact your local distributor or Navman Wireless OEM:

www.navmanwireless.com/oem