

# JUPITER<sup>™</sup> SOLUTIONS

## Datasheet

### J3-A

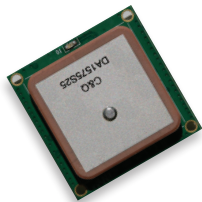

Antenna



Back

## Extra Low Power Fully Integrated Antenna and Receiver

August 9, 2010

### Related Documents

- Navman Wireless OEM NMEA reference manual
- SiRF Binary Protocol reference manual

**CONTENTS**

<b>1.0 Introduction</b> .....	1	<b>Figures</b>	
<b>2.0 Technical description</b> .....	1	Figure 2-1: Receiver architecture .....	2
2.1 Product applications .....	1	Figure 2-2: Antenna – Physical dimensions .....	3
2.2 Receiver architecture .....	2	Figure 2-3: Back – Physical dimensions and pin-out .....	4
2.3 Physical characteristics .....	2	Figure 3-1: Optional LED indicator duty cycle .....	6
2.4 Mechanical specifications – Physical dimensions and pin out assignments .....	3	Figure 4-1: Electrical connections view from solder side ....	8
2.4.1 Antenna – Physical dimensions .....	3	Figure 4-2: Back-up battery circuit.....	?
2.4.2 Back – Physical dimensions and pin-out .....	4		
2.5 Environmental .....	4	<b>Tables</b>	
2.5 Compliance.....	5	Table 3-1: Acquisition times at –125 dBm.....	5
<b>3.0 Performance characteristics</b> .....	5	Table 3-2: Sensitivity .....	7
3.1 TTFF (Time To First Fix) .....	5	Table 3-3: Position and velocity accuracy .....	7
3.1.1 Hot start .....	5	Table 4-1: Power consumption (continuous mode).....	8
3.1.2 Warm start .....	5	Table 4-2: Electrical connections .....	8
3.1.3 Cold start.....	5	Table 5-1: Default NMEA messages .....	9
3.2 Acquisition times .....	5	Table 6-1: Proprietary message parameters .....	9
3.3 Optional LED indicator .....	6	Table 6-2: Proprietary NMEA messages .....	10
3.4 Power management .....	6	Table 7-1: Ordering information.....	10
3.4.1 Adaptive TricklePower .....	6		
3.5 Differential aiding .....	6		
3.5.1 Satellite Based Augmentation Systems (SBAS).....	6		
3.6 Sensitivity .....	7		
3.7 Dynamic constraints .....	7		
3.8 Position and velocity accuracy .....	7		
3.9 Multi-mode aiding .....	7		
<b>4.0 Electrical requirements</b> .....	8		
4.1 Power consumption .....	8		
4.2 Electrical connections .....	8		
4.3 Back-up battery .....	8		
4.4 Data input output.....	8		
<b>5.0 Software interface</b> .....	9		
5.1 NMEA output messages .....	9		
5.1.1 Proprietary NMEA messages .....	9		
5.1.2 Proprietary NMEA input messages .....	10		
<b>6.0 Product handling</b> .....	10		
6.1 Packaging and delivery .....	10		
6.2 Safety.....	10		
6.3 Disposal .....	10		
<b>7.0 Ordering information</b> .....	10		
<b>8.0 Glossary and acronyms</b> .....	11		

## 1.0 Introduction

---

J3-A from Jupiter Solutions is a complete GPS smart antenna solution that has included the patch antenna and high performance receiver circuits that provide superior location capabilities and eliminate the need for external RF connections. The 20-channel ultra-high sensitivity receiver is based on the proven Jupiter3 GPS module. J3-A provides the fastest TTFF (Time to First Fix) possible for all weather conditions, in challenging environments such as densely built cities, heavy foliage, and enclosed spaces. Jupiter Solutions is offered in volume purchase as indicated in Section 7 Ordering Information.

## 2.0 Technical description

---

Jupiter Solutions has enhanced the architecture of the Jupiter3 module by adding carefully selected key components including active antenna, LNA, LDO and driver to comprise the J3-A. This ensures frequency stability, optimized sensitivity at chipset level down to  $-159$  dBm, lower power consumption and a faster TTFF (Time To First Fix).

By providing the optional on-board micro-battery, the J3-A allows rapid satellite acquisition times by preserving system data in SRAM and the power to the RTC section of the Jupiter3 module.

Protocols supported are selected NMEA (National Marine Electronics Association) data messages and SiRF Binary.

### 2.1 Product applications

The J3-A is designed specifically for applications where rapid TTFF and operation under low signal levels along with a small form factor are primary requirements. The module offers high performance and maximum flexibility in a wide range of OEM configurations. The high sensitivity of the module makes it ideal for:

- navigation systems – where athermic glass, or an unsuitably positioned antenna inside the vehicle will reduce visibility and signal strength
- vehicle and people tracking devices – where satellites are obstructed by partially covered car parks and walkways, tracking even continues indoors
- marine buoys – where multipath and unstable sea conditions make satellite visibility irregular
- asset tracking – where construction machinery is located in covered yards and areas of dense foliage
- people tracking - home detention and house arrest applications, emergency location services

## 2.2 Receiver functional architecture

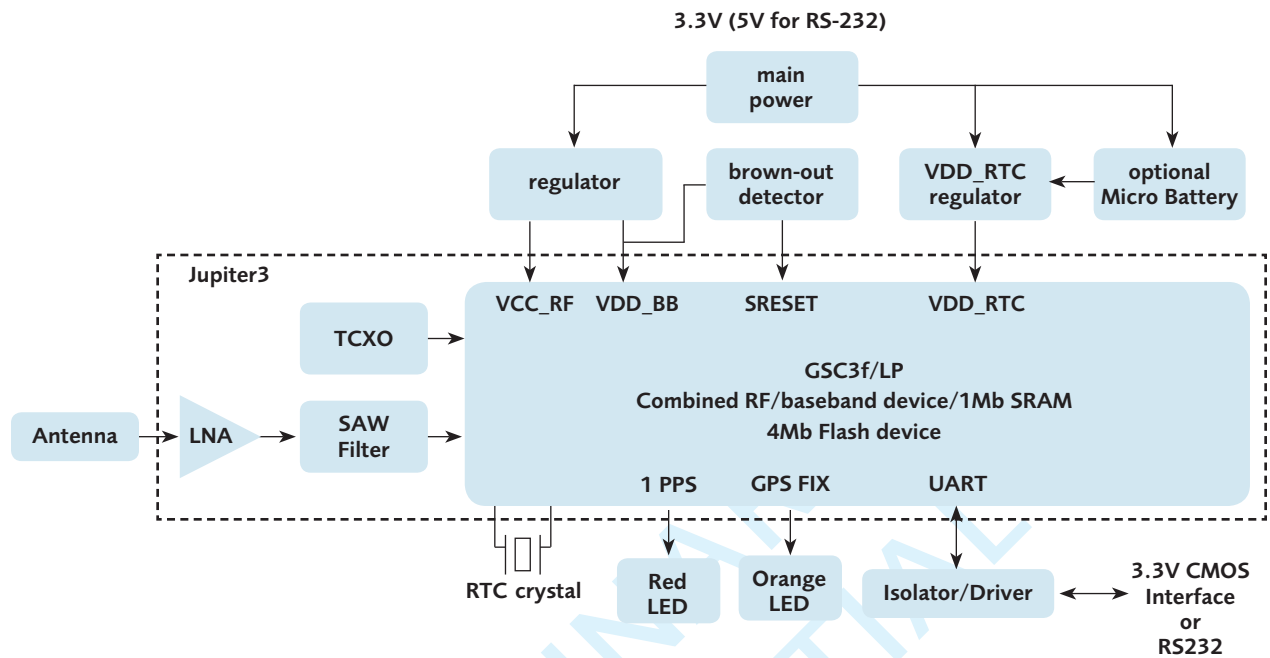

Figure 2-1: Receiver architecture

## 2.3 Physical characteristics

The J3-A is a complete GPS receiver with built-in active patch antenna. The four mounting holes at the corners make it easy to install. There are five(5) electrical solder tabs on the underneath side of the board for electrical connections.

2.4 Mechanical specification

2.4.1 Antenna: Physical dimensions

Dimensions in mm:

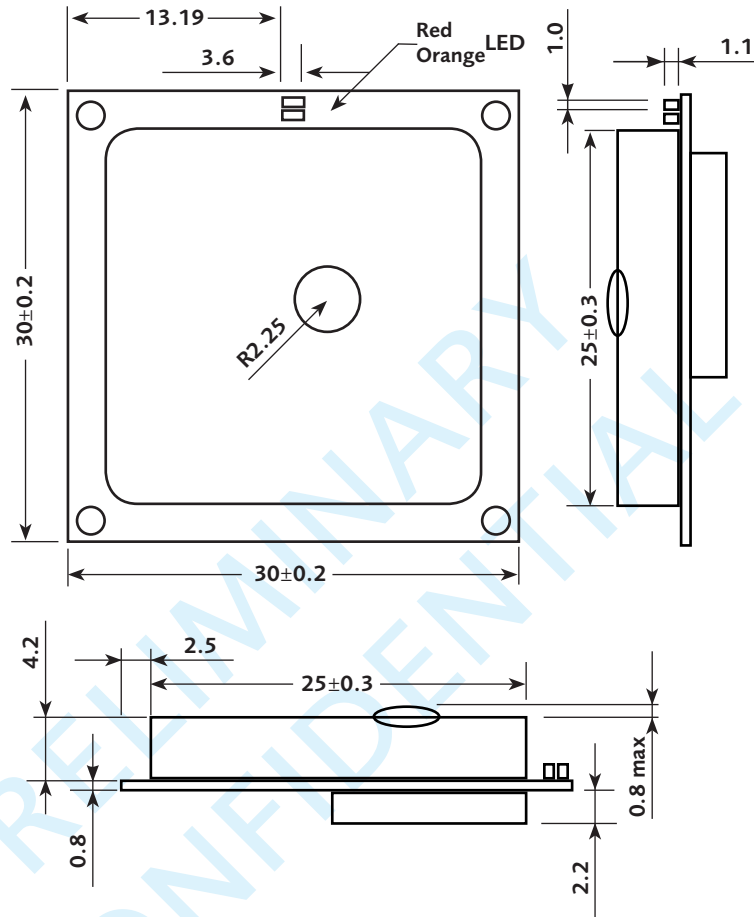

Figure 2-2: Antenna: Physical dimensions

2.4.2 Back: Physical dimensions and pin out assignments

Dimensions in mm

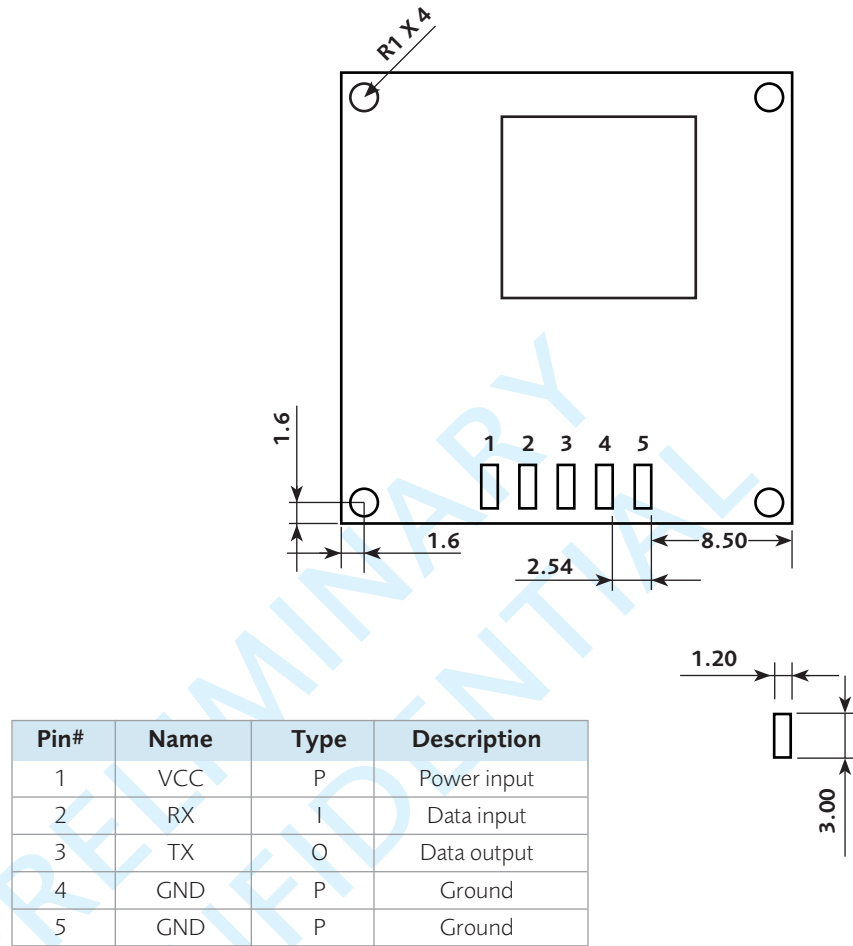

Figure 2-3: Back: Physical dimensions and pin-out

2.5 Environmental

Environmental operating conditions:

- operating temperature without micro battery (Topr): -40°C to +85°C
- operating temperature with micro battery (Topr): 0°C to +60°C
- storage temperature without micro battery (Tstg): -40°C to +85°C (25°C typical)
- storage temperature with micro battery (Tstg): 0°C to +60°C (25°C typical)
- humidity: up to 95% non-condensing or a wet bulb temperature of +35°C
- altitude: -304 m to 18 000 m
- vibration: random vibration IEC 68-2-64
- max. vehicle dynamics: 500 m/s
- shock (non-operating): 18 G peak, 5 ms

## 2.6 Compliances

The J3-A is designed to the following specification:

- Directive 2002/95/EC on the restriction of the use of certain hazardous substances in electrical and electronic equipment (RoHS)
- CISPR22 and FCC: Part 15, Class B for radiated emissions
- Manufactured in an ISO 9000 : 2000 accredited facility

## 3.0 Performance characteristics

### 3.1 TTFF (Time To First Fix)

TTFF is the actual time required by a GPS receiver to achieve a position solution. This specification will vary with the operating state of the receiver, the length of time since the last position fix, the location of the last fix, and the specific receiver design.

Aiding is a method of effectively reducing the TTFF by making every start Hot or Warm.

#### 3.1.1 Hot start

A hot start results from a software reset after a period of continuous navigation, or a return from a short idle period (i.e. a few minutes) that was preceded by a period of continuous navigation. In this state, all of the critical data (position, velocity, time, and satellite ephemeris) is valid to the specified accuracy and available in SRAM. Battery backup of the SRAM and RTC during loss of power is required to achieve a hot start.

#### 3.1.2 Warm start

A warm start typically results from user-supplied position and time initialization data or continuous RTC operation with an accurate last known position available in memory. In this state, position and time data are present and valid but ephemeris data validity has expired.

#### 3.1.3 Cold start

A cold start acquisition results when either position or time data is unknown. Almanac information is used to identify previously healthy satellites.

### 3.2 Acquisition times

Table 3-1 shows the corresponding TTFF times for each of the acquisition modes.

Mode	@ -125 dBm	
	Typ	90%
hot start TTFF	500 ms	< 1 s
warm start TTFF	31 s	36 s
cold start TTFF	33 s	38 s
re-acquisition (<10 s obstruction)	< 1 s	

**Table 3-1: Acquisition times at -125 dBm**

### 3.3 Optional Two LED indicator

J3-A has two optional on-board LEDs on the antenna side for status indication. The definition for each LED is different on the TTL version and RS-232 version of J-3A. If installed, the Red LED will blink once every second after the position is fixed. The Orange LED will either be turned off or turned on after position fix in which it is depended on the version of the J-3A.

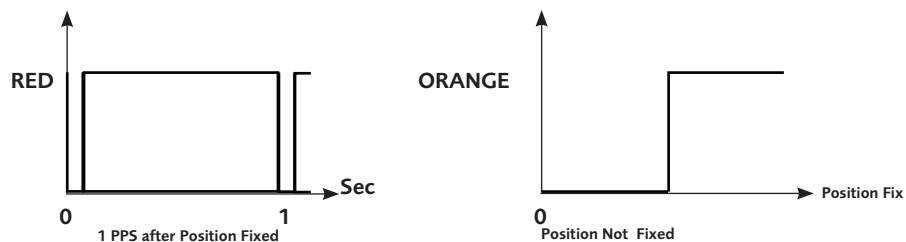

Figure 3-1a: Optional LED indicator duty cycle for TTL Version

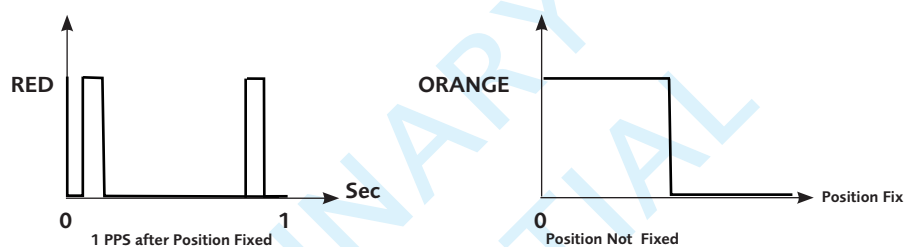

Figure 3-1b: Optional LED indicator duty cycle for RS-232 Version

### 3.4 Power management

J3-A features a built-in micro-battery to preserve system data for rapid satellite acquisition times. This module also offers Adaptive TricklePower, which can be set using NMEA or SiRF Binary messages.

#### 3.4.1 Adaptive TricklePower

J3-A can use the Adaptive TricklePower (ATP) feature, which reduces power consumption by intelligently switching between full power in tough GPS environments and low power in strong GPS signal areas.

When signal levels drop, the receiver returns to full power so that message output rates remain constant. This results in variable power savings but much more reliable performance for a fixed output rate. Applications using ATP should give performance very similar to full power, but with significant power savings in strong signal conditions.

ATP is best suited for applications that require solutions at a fixed rate as well as low power consumption and still maintain the ability to track weak signals.

With ATP at a 1 second update, a power saving of 50% can easily be achieved with minimal degradation in navigation performance.

#### For further information refer to:

- Navman Wireless Low Power Operating Modes application note (LA000513)
- Navman Wireless OEM NMEA reference manual
- SiRF Binary Protocol reference manual

### 3.5 Differential aiding

#### 3.5.1 Satellite Based Augmentation Systems (SBAS)

J3-A is capable of receiving SBAS differential corrections including WAAS and EGNOS. SBAS improves horizontal position accuracy by correcting GPS signal errors caused by ionospheric disturbances, timing and satellite orbit errors.



### 3.6 Sensitivity

Sensitivity of the J3-A at chipset level is measured assuming a system noise value of 3 dB. The sensitivity values are as follows:

Parameter	Signal strength	C/N <sub>0</sub>
acquisition – cold start	-145 dBm	25dBHz
acquisition – hot start	-155 dBm	15 dBHz
navigation	-158dBm	12dBHz
tracking	-159 dBm	10 dBHz

**Table 3-2: Sensitivity**

### 3.7 Dynamic constraints

The J3-A is programmed to deliberately lose track if any of the following limits is exceeded:

- velocity 2D (2 sigma): 500 m/s max
- acceleration: 4 G (39.2 m/s<sup>2</sup>) max
- vehicle jerk: 5 m/s<sup>3</sup> max
- altitude: 18000 m max (referenced to MSL)

### 3.8 Position and velocity accuracy

Position and velocity accuracy are shown in Table 3-3, assuming full accuracy C/A code. These values are the same in normal operation and when Adaptive TricklePower is active.

Parameter	Value
horizontal CEP*	2.5m
horizontal (2 dRMS)	5.5m
vertical VEP*	2.0m
velocity (speed)**	< 0.1 m/s
velocity (heading)**	< 0.1
*position error 50% and under normal open sky conditions	
**In 3D Kalman filtered mode in steady state open sky conditions	

**Table 3-3: Position and velocity accuracy**

### 3.9 Multi-mode aiding

Multi-mode aiding technology makes navigation information available to GPS devices when Satellite Vehicles (SVs) are not visible due to obstruction. In autonomous operation mode, the GPS receiver requires a signal level of 28 dBHz or higher in four or more SVs to download ephemerides. This requires an uninterrupted full 30 seconds of data reception from each SV. If data is not received in full, the ephemeris data collection starts again at the next cycle.

Ephemeris Push is the multi-mode aiding currently supported by the J3-A (Binary mode only). This feature supports live ephemeris data download from application servers, which is then transmitted to the GPS receiver through a network connection. This feature facilitates hot start performance at all times, including weak conditions and moving start ups. The ephemeris is typically valid for 4 hours until the live ephemeris is downloaded or new ephemeris data is provided.

An application note about Ephemeris Push is in preparation and will be available at a later date.

## 4.0 Electrical requirements

### 4.1 Power consumption

See Table 4-1 for J3-A continuous mode power consumption details.

Parameter	Symbol	Product	Typ
input voltage	VCC	J3-A TTL	3.3V
		J3-A 232	5V
input voltage	Icc	J3-A TTL	38mA*
		J3-A 232	40mA*

\*measured when position fix is available

**Table 4-1: Power consumption (continuous mode)**

### 4.2 Electrical Connections

The J3-A module has five (5) electrical solder tabs for electrical connections on the underside of the board. Input supply voltage and serial transmit and receive data connections are shown in Figure 4-1 below.

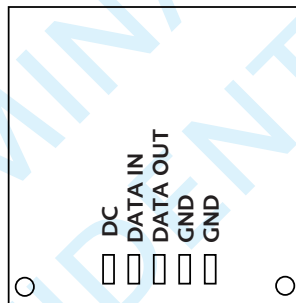

**Figure 4-1: Electrical Connections view from solder side**

The table below contains electrical properties for each of these connections.

Connection	Description	Notes
DC	Main supply voltage	3.3V for TTL / 5V for RS-232
Data in	Serial Data Input	CMOS 3.3V / RS-232
Data Out	Serial Data Output	CMOS 3.3V / RS-232
GND	Ground DC	Negative Supply
GND	Ground	Cable Shield (or blank)

**Table 4-2: Electrical Connections**

### 4.3 Back-up Battery

The J3-A has an optional micro-battery required for warm and hot starts. Battery charging occurs anytime the VCC supply is present. This battery is rated for hundreds of charging cycles where the battery has been completely discharged; however as long as the power is applied for a few hours every three to four days, a full discharge will not occur.

### 4.4 Data Input Output

The serial data input/output connections are standard 3V CMOS. Direct interface to a microprocessor requires normal caution with respect to CMOS levels and lead lengths. For driving a RS-232 Circuit, an alternative configuration with RS232 interface is available. The details are shown in the Section 7 Ordering Information.

## 5.0 Software interface

Protocols supported are selected NMEA (National Marine Electronics Association) -0183 and SiRF Binary messages: latitude, longitude, elevation, velocity, heading, time, satellite tracking status, command/control messages.

The default serial modes are as follows:

NMEA, 9600 bps, 8 data bits, no parity, 1 stop bit

### 5.1 NMEA output messages

NMEA is a standard protocol used by GPS receivers to transmit data. The output NMEA (0183 v3.0) messages for the J3-A are listed in Table 5-1. A complete description of each NMEA message is contained in the Navman Wireless OEM NMEA reference manual.

Message ID and description	Refresh rate
GGA – global positioning system fix data	1 s
GLL – geographic position - latitude, longitude	1 s
GSV – satellites in view	1 s
GSA – DOP and active satellites	1 s
RMC – recommended minimum specific GPS data	1 s
VTG – course over ground and ground speed	1 s
ZDA – PPS timing message	1 s

Table 5-1: Default NMEA messages

### 5.2 Proprietary NMEA messages

Table 5-2 shows the proprietary message parameters.

Start sequence	Payload	Checksum	End sequence
\$PSRF<MID> <sup>1</sup>	Data <sup>2</sup>	CKSUM <sup>3</sup>	<CR><LF> <sup>4</sup>
1. Message Identifier consisting of three numeric characters. Input messages begin at MID 100. 2. Message specific data. Refer to a specific message section for <data>...<data> definition. 3. CKSUM is a two-hex character checksum as defined in the NMEA specification, NMEA-0183Standard For Interfacing Marine Electronic Devices. Use of checksums is required on all input messages. 4. Each message is terminated using Carriage Return (CR) Line Feed (LF) which is \r\n which is hex 0D0A. Because \r\n are not printable ASCII characters, they are omitted from the example strings, but must be sent to terminate the message and cause the receiver to process that input message.			

Table 5-2: Proprietary message parameters

**Note:** All fields in all proprietary NMEA messages are required, none are optional. All NMEA messages are comma delimited.

Table 5-3 shows the proprietary input message descriptions.

Message	MID*	Description
SetSerialPort	100	Set PORT A parameters and protocol
NavigationInitialization	101	Parameters required for start using X/Y/Z**
Query/Rate Control	103	Query standard NMEA message and/or set output rate
LLANavigationInitialization	104	Parameters required for start using Lat/Lon/Alt**
Development Data On/Off	105	Development Data messages On/Off
Select Datum	106	Selection of datum to be used for coordinate transformations
Get Navman SW Version	200	Poll software version information
Store Config-to-Flash	220	Store receiver configuration parameters to Flash
Trickle-Power Mode Configuration	221	Configure Trickle-Power mode
User Configuration	223	Set user configuration
*Message Identification (MID)		
**Input coordinates must be WGS84		

**Table 5-3: Proprietary NMEA input messages**

## 6.0 Product handling

### 6.1 Packaging and delivery

The MOQ (Minimum Order Quantity) for shipping is 250 units.

### 6.2 Safety

Improper handling and use of the Jupiter GPS receiver can cause permanent damage to the receiver and may even result in personal injury.

### 6.3 Disposal

This product should not be treated as household waste. For more detailed information about recycling of this product, please contact your local waste management authority or the seller from whom you purchased the product.

## 7.0 Ordering information

The part numbers of J3-A are shown in Table 7.1. Minimum order quantity for each configuration is 1000 units.

Part Number	Configuration	Description
J3-A	J3-ATT0-00-350.14	TTL interface, with Micro Battery, with LED
J3-A	J3-ATT1-00-350.14	TTL without Micro Battery, without LED
J3-A	J3-ARS0-00-350.14	RS232 interface, with Micro Battery, with LED
J3-A	J3-ARS1-00-350.14	RS232 without Micro Battery, without LED

Note: Custom firmware for High Altitude application is available, please contact your sales manager for details

**Table 7-1: Ordering information**

### 8.0 Glossary and acronyms

---

**2dRMS:** twice-distance Root Mean Square

A horizontal measure of accuracy representing the radius of a circle within which the true value lies at least 95% of the time.

**Almanac:** A set of orbital parameters that allows calculation of approximate GPS satellite positions and velocities. The almanac is used by a GPS receiver to determine satellite visibility and as an aid during acquisition of GPS satellite signals. The almanac is a subset of satellite ephemeris data and is updated weekly by GPS Control.

**C/A code:** Course Acquisition code

A spread spectrum direct sequence code that is used primarily by commercial GPS receivers to determine the range to the transmitting GPS satellite.

**C/N0:** Carrier to Noise ratio

**GDOP:** Geometric Dilution of Precision

A factor used to describe the effect of the satellite geometry on the position and time accuracy of the GPS receiver solution. The lower the value of the GDOP parameter, the less the error in the position solution. Related indicators include PDOP, HDOP, TDOP and VDOP.

**EGNOS:** European Geostationary Navigation Overlay Service

The system of geostationary satellites and ground stations developed in Europe to improve the position and time calculation performed by the GPS receiver.

**Ephemeris:** A set of satellite orbital parameters that is used by a GPS receiver to calculate precise GPS satellite positions and velocities. The ephemeris is used to determine the navigation solution and is updated frequently to maintain the accuracy of GPS receivers.

**GPS:** Global Positioning System

A space-based radio positioning system that provides accurate position, velocity, and time data.

**OEM:** Original Equipment Manufacturer

**Re-acquisition:** The time taken for a position to be obtained after all satellites have been made invisible to the receiver.

**SBAS:** Satellite Based Augmentation System

Any system that uses a network of geostationary satellites and ground stations to improve the performance of a Global Navigation Satellite System (GNSS). Current examples are EGNOS and WAAS.

**SRAM:** Static Random Access Memory

**SAW filter:** Surface Acoustic Wave filter

**WAAS:** Wide Area Augmentation System

The system of satellites and ground stations developed by the FAA (Federal Aviation Administration) that provides GPS signal corrections. WAAS satellite coverage is currently only available in North America

© 2010 Navman Wireless OEM. All Rights Reserved.

SiRF and SiRF logo are registered trademarks of SiRF Technology, Inc. SiRFstar, SiRFLoc, Push-to-Fix, and Trickle-Power are trademarks of SiRF Technology, Inc. All other trademarks mentioned in this document are property of their respective owners.

Information in this document is provided in connection with Navman Wireless OEM ('Navman') products. These materials are provided by Navman as a service to its customers and may be used for informational purposes only. Navman assumes no responsibility for errors or omissions in these materials. Navman may make changes to specifications and product descriptions at any time, without notice. Navman makes no commitment to update the information and shall have no responsibility whatsoever for conflicts or incompatibilities arising from future changes to its specifications and product descriptions. No license, express or implied, by estoppel or otherwise, to any intellectual property rights is granted by this document. Except as provided in Navman's Terms and Conditions of Sale for such products, Navman assumes no liability whatsoever.

THESE MATERIALS ARE PROVIDED 'AS IS' WITHOUT WARRANTY OF ANY KIND, EITHER EXPRESSED OR IMPLIED, RELATING TO SALE AND/OR USE OF NAVMAN PRODUCTS INCLUDING LIABILITY OR WARRANTIES RELATING TO FITNESS FOR A PARTICULAR PURPOSE, CONSEQUENTIAL OR INCIDENTAL DAMAGES, MERCHANTABILITY, OR INFRINGEMENT OF ANY PATENT, COPYRIGHT OR OTHER INTELLECTUAL PROPERTY RIGHT. NAVMAN FURTHER DOES NOT WARRANT THE ACCURACY OR COMPLETENESS OF THE INFORMATION, TEXT, GRAPHICS OR OTHER ITEMS CONTAINED WITHIN THESE MATERIALS. NAVMAN SHALL NOT BE LIABLE FOR ANY SPECIAL, INDIRECT, INCIDENTAL, OR CONSEQUENTIAL DAMAGES, INCLUDING WITHOUT LIMITATION, LOST REVENUES OR LOST PROFITS, WHICH MAY RESULT FROM THE USE OF THESE MATERIALS.

Navman products are not intended for use in medical, lifesaving or life sustaining applications. Navman customers using or selling Navman products for use in such applications do so at their own risk and agree to fully indemnify Navman for any damages resulting from such improper use or sale. Product names or services listed in this publication are for identification purposes only, and may be trademarks of third parties. Third-party brands and names are the property of their respective owners. Additional information, posted at [www.navmanwirelessoem.com](http://www.navmanwirelessoem.com), is incorporated by reference. Reader response: Navman strives to produce quality documentation and welcomes your feedback. Please send comments and suggestions to [Americatechsupport@navmanwirelessoem.com](mailto:Americatechsupport@navmanwirelessoem.com). For technical questions, contact your local Navman sales office or field applications engineer.

PRELIMINARY  
CONFIDENTIAL

This page is blank.

PRELIMINARY  
CONFIDENTIAL