

**Technical  
Information**



*MOTOROLA G24 JAVA HMI*

*DISPLAY INTEGRATION GUIDE*



**ENGLISH**  
**MARCH 15, 2008**  
**6802985C15-A**

## REVISION HISTORY

Revision	Date	Purpose
A	March 15, 2008	Initial release



## CHAPTER 4 - SOFTWARE SPECIFICATIONS

4.1 GENERAL.....	23
4.2 MOTOROLA PROPRIETARY JAVA INTERFACE FOR FPGA & DISPLAY CONFIGURATION .....	23
4.2.1 FPGA Programming Via UM .....	23
4.2.2 Resolution .....	23
4.2.3 FPGA & Display Manufacturer Commands.....	24

# CHAPTER 1 - INTRODUCTION

---

---

---

---

---

---

---

---

---

---

## 1.1 PURPOSE

This guide provides Hardware and Software details required for the G24-J HMI display integration.

The descriptions given in this guide are based on a Reference Display Board.

To obtain a Reference Display Board, please contact M2M Customer Care: [M2MCare@motorola.com](mailto:M2MCare@motorola.com)

The main objectives of this guide are:

- General understanding of operating the reference design board
- Give tools for designing a customer's board with a G24-J HMI
- Knowledge of the Java interface for the FPGA & display configuration.

## 1.2 INTENDED AUDIENCE

This guide is intended for Motorola Wireless Modules customers designing a device that requires Display and/or keypad capability.

## 1.3 DISCLAIMER

Motorola reserves the right to make changes without notice to any of the products or services described herein. "Typical" parameters, which may be provided in Motorola Data sheets and/or specifications can and do vary in different applications and actual performance may vary. Customer's technical experts will validate all "Typicals" for each customer application.

Motorola makes no warranty in regard to the products or services contained herein. Implied warranties, including without limitation, the implied warranties of merchantability and fitness for a particular purpose, are given only if specifically required by applicable law. Otherwise, they are specifically excluded.

No warranty is made as to coverage, availability, or grade of service provided by the products or services, whether through a service provider or otherwise.

No warranty is made that the software will meet your requirements or will work in combination with any hardware or application software products provided by third parties, that the operation of the software products will be uninterrupted or error free, or that all defects in the software products will be corrected.

In no event shall Motorola be liable, whether in contract or tort (including negligence), for any damages resulting from use of a product or service described herein, or for any indirect, incidental, special or consequential damages of any kind, or loss of revenue or profits, loss of business, loss of information or data, or other financial loss arising out of or in connection with the ability or inability to use the Products, to the full extent these damages may be disclaimed by law.

Some states and other jurisdictions do not allow the exclusion or limitation of incidental or consequential damages, or limitation on the length of an implied warranty, therefore the above limitations or exclusions may not apply to you.

This warranty gives you specific legal rights, and you may also have other rights, which vary from jurisdiction to jurisdiction.

## CHAPTER 1 - INTRODUCTION

Motorola products or services are not designed, intended, or authorized for use as components in systems intended for surgical implant into the body, or other applications intended to support or sustain life, or for any other application in which the failure of the Motorola product or service could create a situation where personal injury or death may occur.

Should the buyer purchase or use Motorola products or services for any such unintended or unauthorized application, the buyer shall release, indemnify and hold Motorola and its officers, employees, subsidiaries, affiliates, and distributors harmless against all claims, costs, damages, and expenses, and reasonable attorney fees arising out of, directly or indirectly, any claim of personal injury or death associated with such unintended or unauthorized use, even if such claim alleges that Motorola was negligent regarding the designing or manufacturing of the product or service.

Motorola recommends that if you are not the author or creator of the graphics, video, or sound, you obtain sufficient license rights, including the rights under all patents, trademarks, trade names, copyrights, and other third party proprietary rights.

### 1.4 ABBREVIATIONS, ACRONYMS AND DEFINITIONS

Abbreviation	Full Name
EVB	<b>E</b> valuation <b>B</b> oard
Flex	G24 configuration file, allows product <b>flex</b> ibility
G24-J	<b>G</b> 24 <b>J</b> ava
GPIO	<b>G</b> eneral <b>P</b> urpose <b>I</b> nput <b>O</b> utput
HMI	<b>H</b> uman <b>M</b> achine <b>I</b> nterface. G24 with display and keypad support
JAD	<b>J</b> ava <b>A</b> pplication <b>D</b> escriptor
JAR	<b>J</b> ava <b>A</b> rchive
Kjava	<b>K</b> ilobyte Java
KMgr pin	<b>K</b> JAVA <b>M</b> anager GPIO pin
M2M	<b>M</b> achine to <b>M</b> achine
MIDlet	An application that conforms to the MIDP standard.
MIDP	<b>M</b> obile <b>I</b> nformation <b>D</b> evice <b>P</b> rofile
NVM	<b>N</b> on <b>V</b> olatile <b>M</b> emory
OEM	<b>O</b> riginal <b>E</b> quipment <b>M</b> anufacturer
UART	<b>U</b> niversal <b>A</b> synchronous <b>R</b> eceiver/ <b>T</b> ransmitter
UM	<b>U</b> ser <b>M</b> IDlet
URL	<b>U</b> niform <b>R</b> esource <b>L</b> ocator

### 1.5 TRADEMARKS

MOTOROLA and the Stylized M Logo are registered in the U.S. Patent and Trademark Office. All other product or service names are the property of their respective owners.

### 1.6 APPLICABLE DOCUMENTATION

- [1] Motorola G24 KJAVA User Guide, at [G24-J MOTODEV Web Page](#)
- [2] MOTO2MOTO API Javadoc, available in ‘MOTO2MOTO Wireless Toolkit Powered by Sun Java(TM) Technology’ and ‘MOTODEV SDK for Java(TM) ME’

## 1.7 PROBLEM REPORTING INSTRUCTIONS

Problems or corrections to this guide should be reported to M2M Customer Care by mail: [M2MCare@motorola.com](mailto:M2MCare@motorola.com)

## 1.8 HOW THIS GUIDE IS ORGANIZED

This guide contains the following chapters:

- **Chapter 1** - Introduction
- **Chapter 2** - Overview
- **Chapter 3** - Hardware Specifications
- **Chapter 4** - Software Specifications





# CHAPTER 2 - OVERVIEW

---

---

---

---

---

---

---

---

---

---

## 2.1 INTRODUCTION

The HMI unit is a model of G24-J that can be integrated with a display through a FPGA interface. The display and keypad will be available only for Java applications (MIDlets). The display will be controlled by standard KJava libraries.

The following paragraphs give two alternatives for display integration.

## 2.2 DISPLAY CONNECTED WITHOUT PROM (PLATFORM FLASH)

The configuration file (FPGA's firmware) will be loaded from the G24-J's NVM to the FPGA upon each power up (see Figure 1).

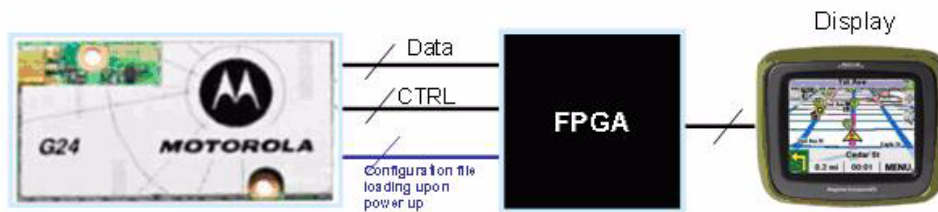

Figure 1. G24-J Loads the FPGA Configuration File

## 2.3 DISPLAY CONNECTED WITH PROM

The configuration file (FPGA's firmware) will be loaded from an external memory (PROM) to the FPGA upon each power up (see Figure 2).

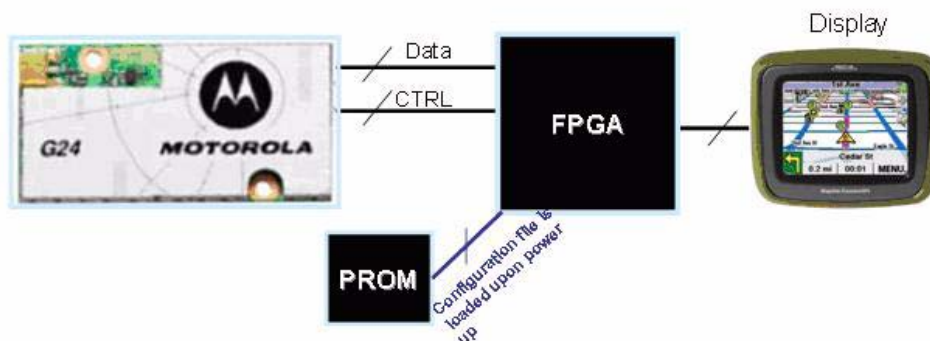

Figure 2. PROM Loads the FPGA Configuration FILE



# CHAPTER 3 - HARDWARE SPECIFICATIONS

## 3.1 GENERAL

The Hardware specifications are detailed by a demonstration of a Reference Display Board designed at Motorola as a display integration model for the G24-J HMI customers.

## 3.2 G24-J DISPLAY BOARD LAYOUT

Figure 3 and Figure 4 below shows the reference display board layout. This layout will help you understand the reference display board, as well as help you design your application over the G24-J HMI.

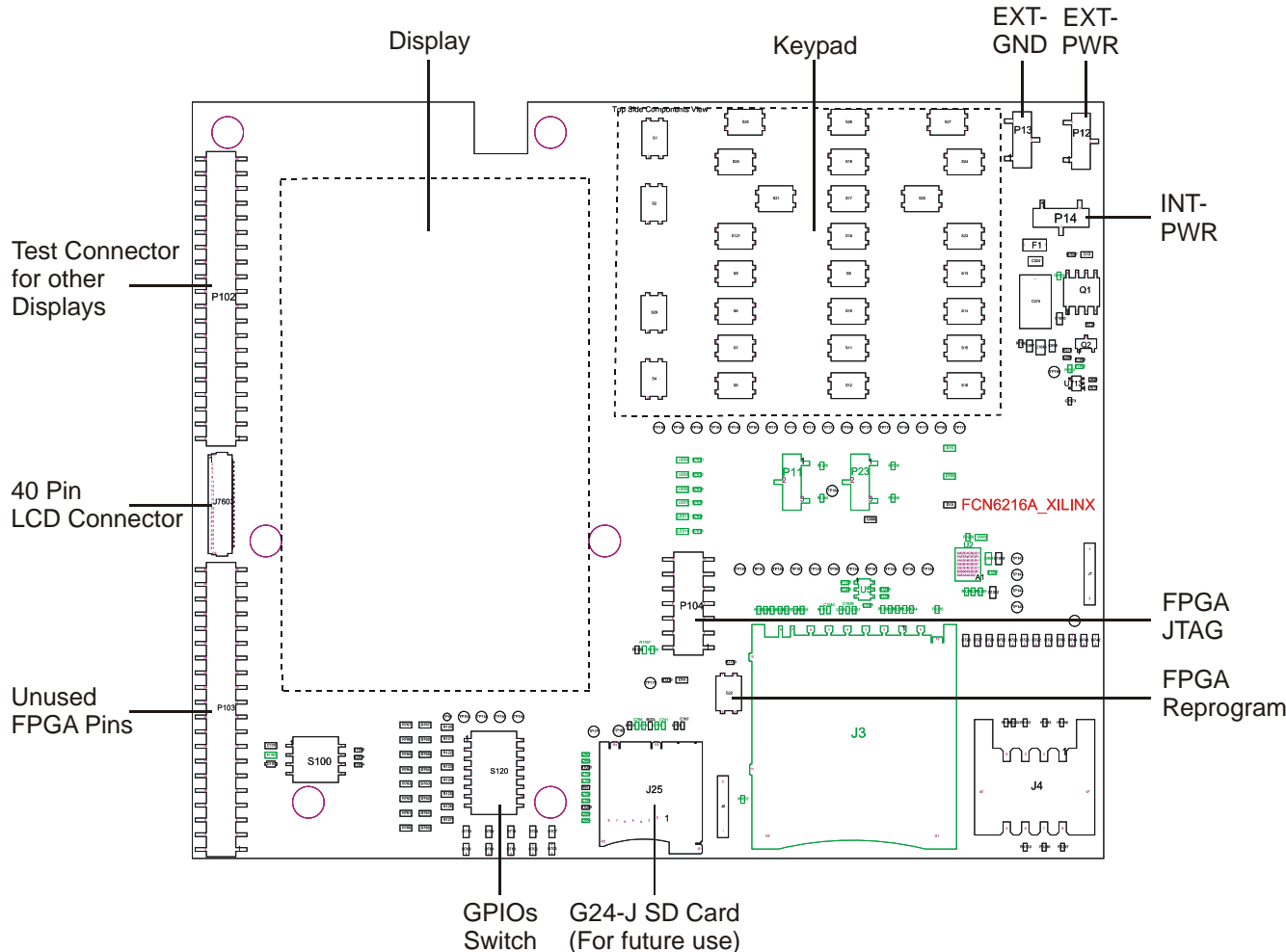

Figure 3. G24-J Display Board Layout - Top View

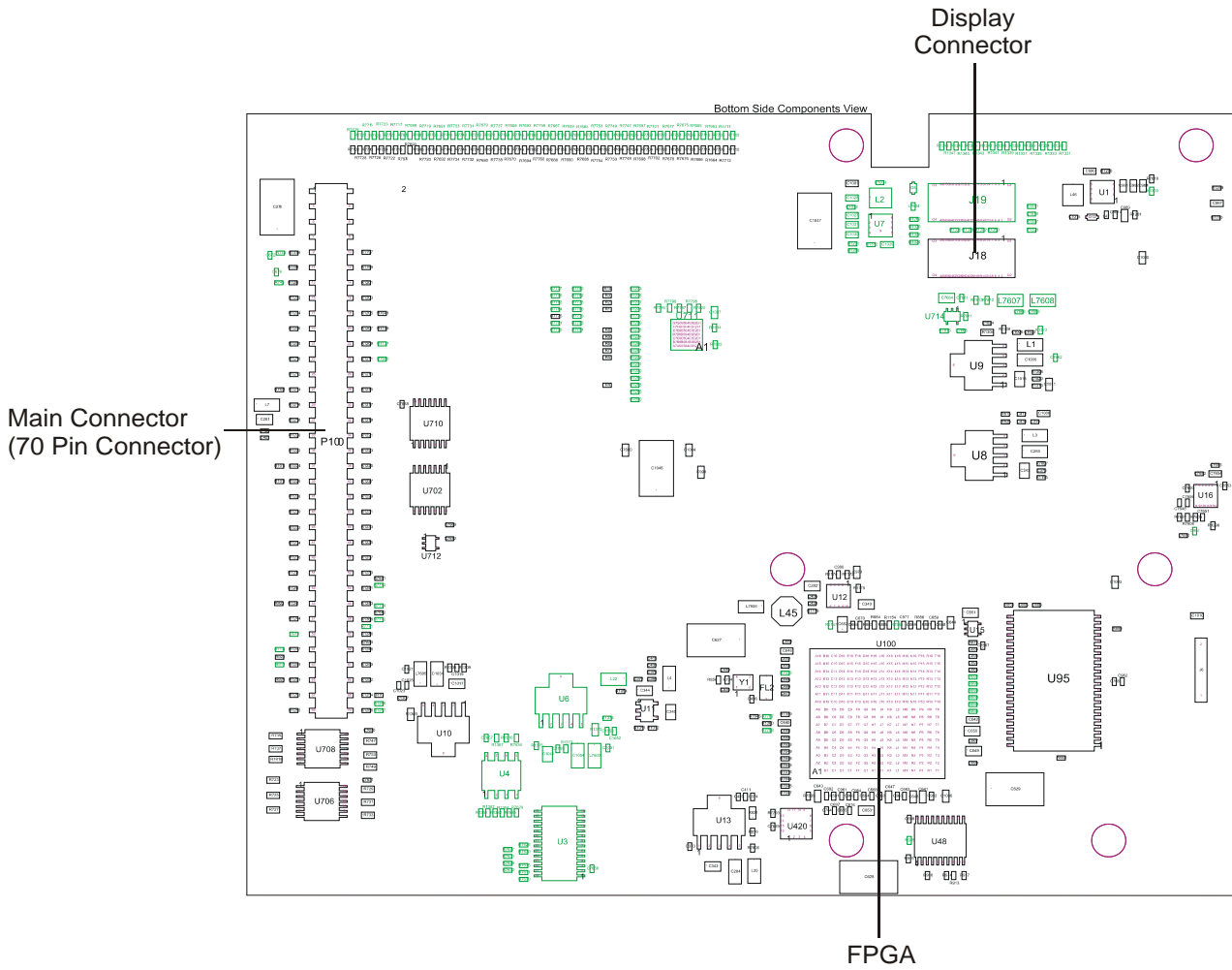

Figure 4. G24-J Display Board Layout - Bottom View

### 3.3 G24-J DISPLAY BOARD WITH G24-J HMI LAYOUT

Figure 5 shows the location of the main components on the Display Board, with a G24-J HMI installed.

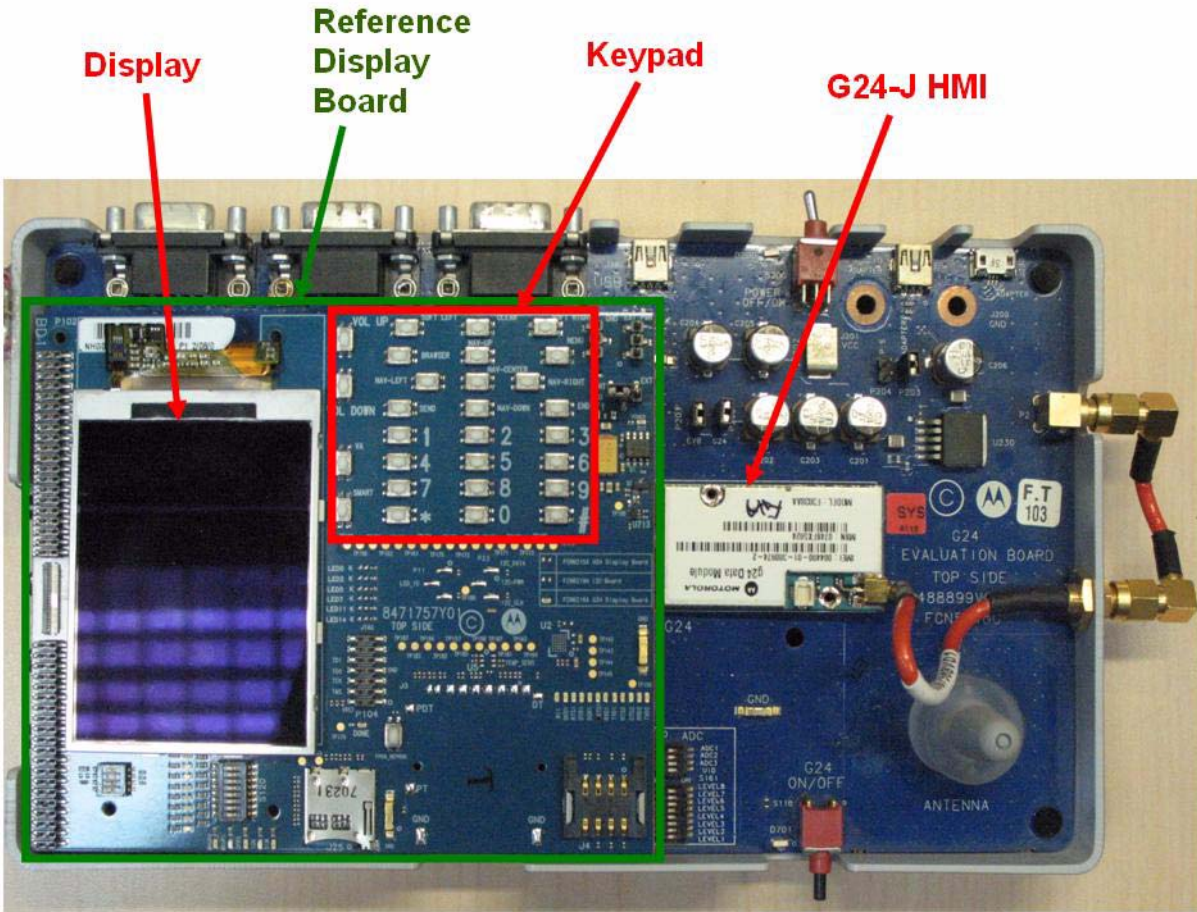

Figure 5. G24-J Display Board with G24-J HMI - Layout



**Note**

- The Display Board receive its power via the main connector.
- The display can only work with a G24-J HMI module connected.
- The Display Board is plugged onto the 70 pin connector (P100) on the EVB.

### 3.4 BOARD CONFIGURATION

In order to operate and configure the Display Board, the following guidelines should be considered:

#### 3.4.1 Power

The Display Board receives power in one of two ways:

1. INT\_PWR (Normal operation).
  - Place a jumper between left and middle pins of **P14**.
2. EXT\_PWR.
 

To use this option:

  - Place a jumper between right and middle pins of **P14**.
  - Connect **P12** to VCC.
  - Connect **P13** to GND.



**Note**

- Operation voltage is 4V to 4.8V.
- Make sure that all dip switches on the Display Board are set to H/OFF (left side).

#### 3.4.2 FPGA Programming

The FPGA does not have a NVM for holding the configuration file when its power is off. So it must be programmed upon every power up. The FPGA may be programmed using the following two ways:

- Via UM (G24-J User MIDlet) - set **S100 switch 3** to "OFF"
- Via on-board PROM - set **S100 switch 3** to "ON"

##### 3.4.2.1 FPGA Programming Via UM

The configuration file is saved in the G24-J's NVM. The G24-J programs the FPGA upon power up.

##### Connecting the GPIOs for FPGA Programming

Four of the G24-J GPIOs are used for programming the FPGA (see Table 1). Once programming is done, three of the GPIOs below may be re-routed by the FPGA. Once re-routed, these lines will be available for the GPIO API, see column "Available for GPIO API" in Table 1.

FPGA also outputs a line "DONE" to indicate a successful programming of the configuration file. This line is not processed by the G24-J. The user may connect this FPGA line.

**Table 1: Pins Required for FPGA Programming**

70 Pin Conn. Pin No.	Original Usage	FPGA Programming Usage		Pin Direction	Available for GPIO API
		Name	Description		
26	GPIO11	<b>FPGA_PROG_B</b>	Reset FPGA and start configuration.	Out	No
23	GPIO12	<b>FPGA_INIT_B</b>	A problem occurred, start image loading from the beginning.	In	Yes

Table 1: Pins Required for FPGA Programming (Continued)

70 Pin Conn. Pin No.	Original Usage	FPGA Programming Usage		Pin Direction	Available for GPIO API
		Name	Description		
13	GPIO13	FPGA_CCLK	Clock.	Out	Yes
19	GPIO14	PROM_D0	Configuration data.	Out	Yes



Note

For more details regarding programming the FPGA through the G24-J UM, refer to CHAPTER 4 - SOFTWARE SPECIFICATIONS.

### 3.4.2.2 FPGA Programming Via On-Board PROM

Using this configuration, the PROM holds the configuration file, and programs the FPGA upon power up. Below, there's a description of how to use Xilinx iMPACT application in order to program the PROM through the JTAG on the display's Reference Board.



Note

In order to reprogram the FPGA from the PROM when the G24-J is already powered up - press and release **S22**. Of course, this function is only valid for on board PROM configuration.

#### PROM Programming Procedure

The FPGA and the PROM are both connected to a JTAG chain (see Figure 6):

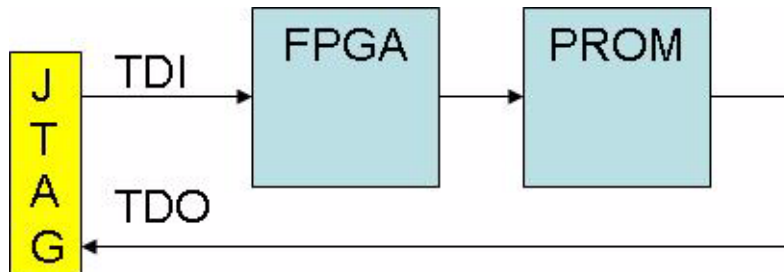

Figure 6. JTAG Chain

Use the [Xilinx iMPACT](#) tool and follow these steps (with the help of the screens):

1. Connect to the JTAG chain using the 'Boundary Scan' button.

## CHAPTER 3 - HARDWARE SPECIFICATIONS

2. Double click the PROM IC.

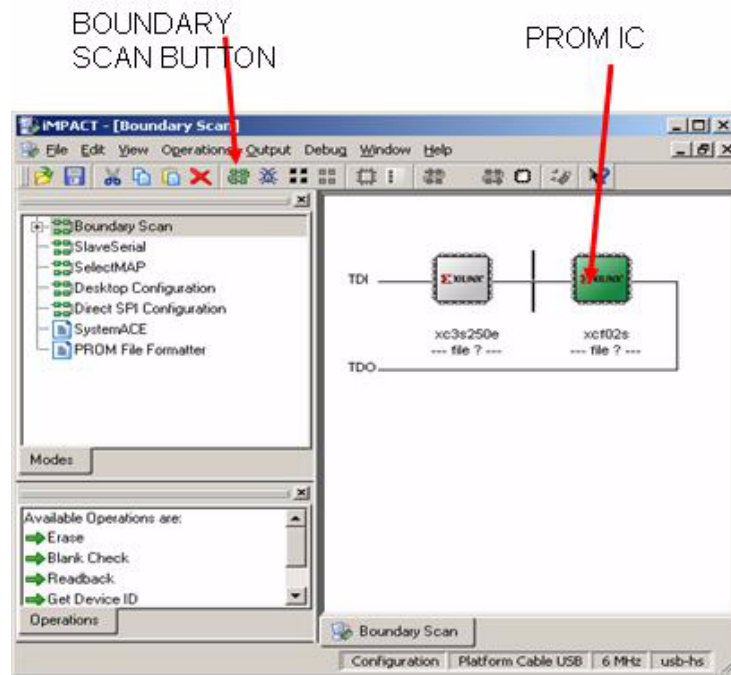

3. Select file you want to program.
4. Right click on the PROM IC.

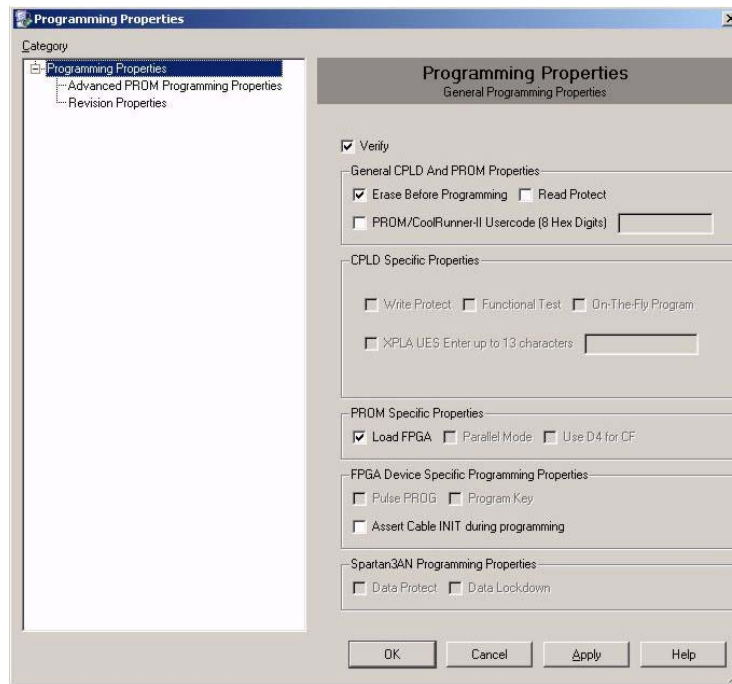

5. Select Load FPGA and press OK.



- Verify that the Program Succeeded message appears and Done LED is ON.

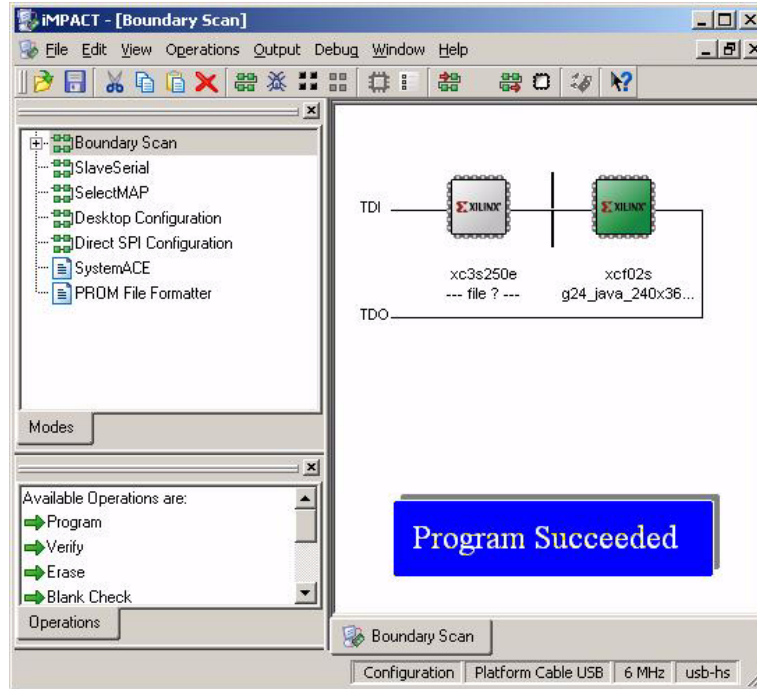

## 3.5 CONNECTORS

### 3.5.1 P103

Xilinx unused (spare) GPIOs: most FPGA IOs that are not in used are routed to this connector; these IOs can be used by the customer for their application and needs.

GPIO Pin Number on FPGA	Pin Number on P103	Pin Number on P103	GPIO Pin Number on FPGA
E6	1	2	GND
K13	3	4	N16
E9	5	6	G2
D5	7	8	B1
B16	9	10	C1
M16	11	12	D1
H16	13	14	D16
D11	15	16	D10
H15	17	18	E10
A3	19	20	A10
B10	21	22	D9
C12	23	24	A7

GPIO Pin Number on FPGA	Pin Number on P103	Pin Number on P103	GPIO Pin Number on FPGA
J14	25	26	P16
F14	27	28	E11
J11	29	30	C13
M13	31	32	R15
C11	33	34	R16
L15	35	36	J12
J16	37	38	3V
GND	39	40	2.5V

### 3.5.2 P102

Test connector for other Displays connection.

Description	Pin Number on P102	Pin Number on P102	Description
LCD_ID0	1	2	LCD_SDO
LCD_RED5	3	4	LCD_SDI
LCD_RED4	5	6	GND
LCD_RED3	7	8	LCD_VSYNC
LCD_RED2	9	10	GND
LCD_RED1	11	12	LCD_HSYNC
LCD_RED0	13	14	GND
LCD_GREEN5	15	16	LCD_MCLK
LCD_GREEN4	17	18	GND
LCD_GREEN3	19	20	LCD_SD
LCD_GREEN2	21	22	LCD_TB_RL
LCD_GREEN1	23	24	LCD_CS_OUT
LCD_GREEN0	25	26	2_775V
LCD_BLUE0	27	28	2_775V
LCD_BLUE1	29	30	LCD_SCLK
LCD_BLUE2	31	32	LED_ANODA
LCD_BLUE3	33	34	LED_PWM
LCD_BLUE4	35	36	B+
LCD_BLUE5	37	38	LED_CATODA
GND	39	40	GND

### 3.6 SCHEMATICS

The following are the Display Board schematic diagrams.

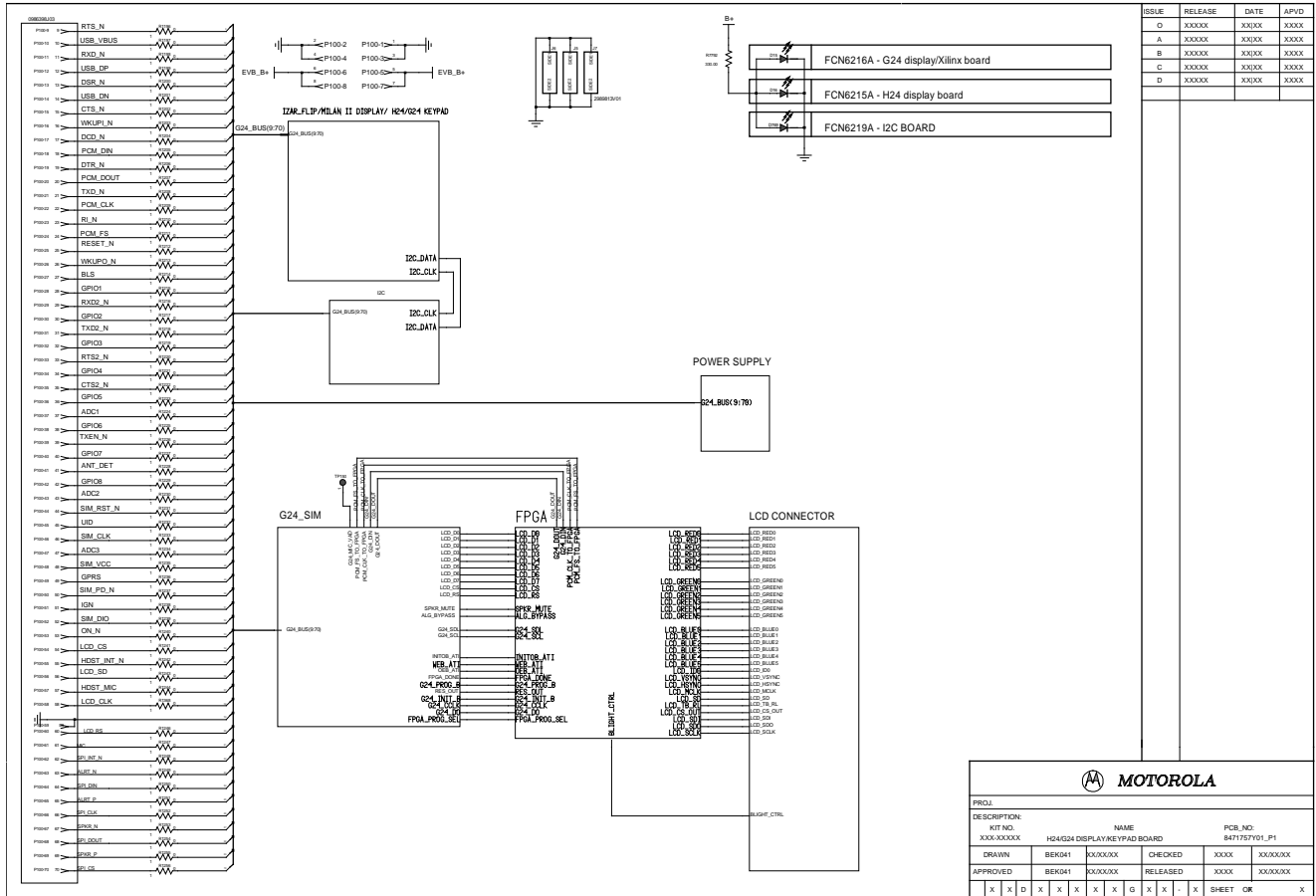

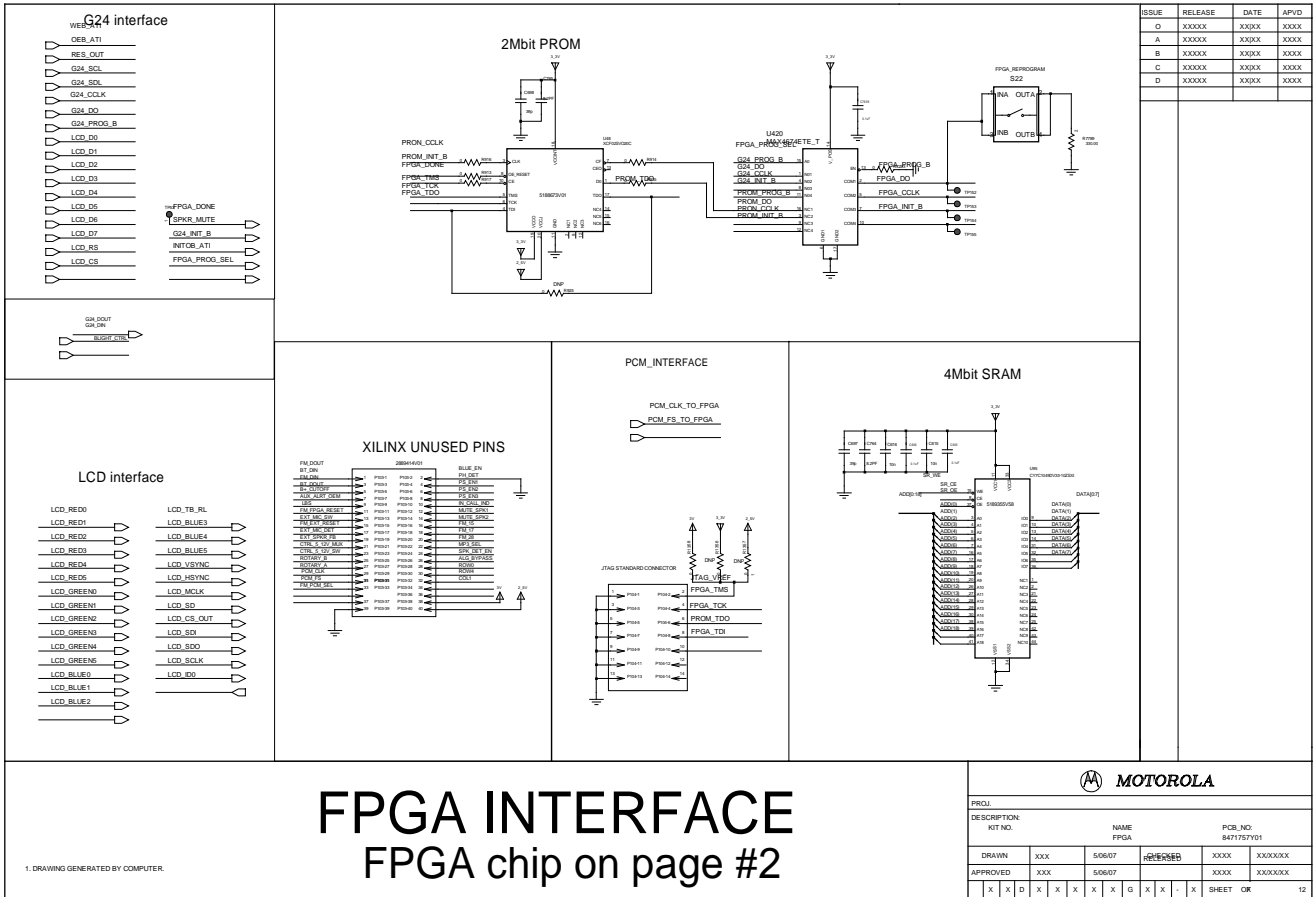

# FPGA INTERFACE

## FPGA chip on page #2

1. DRAWING GENERATED BY COMPUTER.

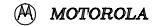

DESCRIPTION:		NAME:		PCB_NO:	
KIT NO.		FPGA		8471757Y01	
DRAWN	XXX	506507	428058B	XXXX	XXXXXXX
APPROVED	XXX	506507		XXXX	XXXXXXX
X	X	D	X	X	X
X	X	G	X	X	X
X	X	X	X	X	X
SHEET 08					12

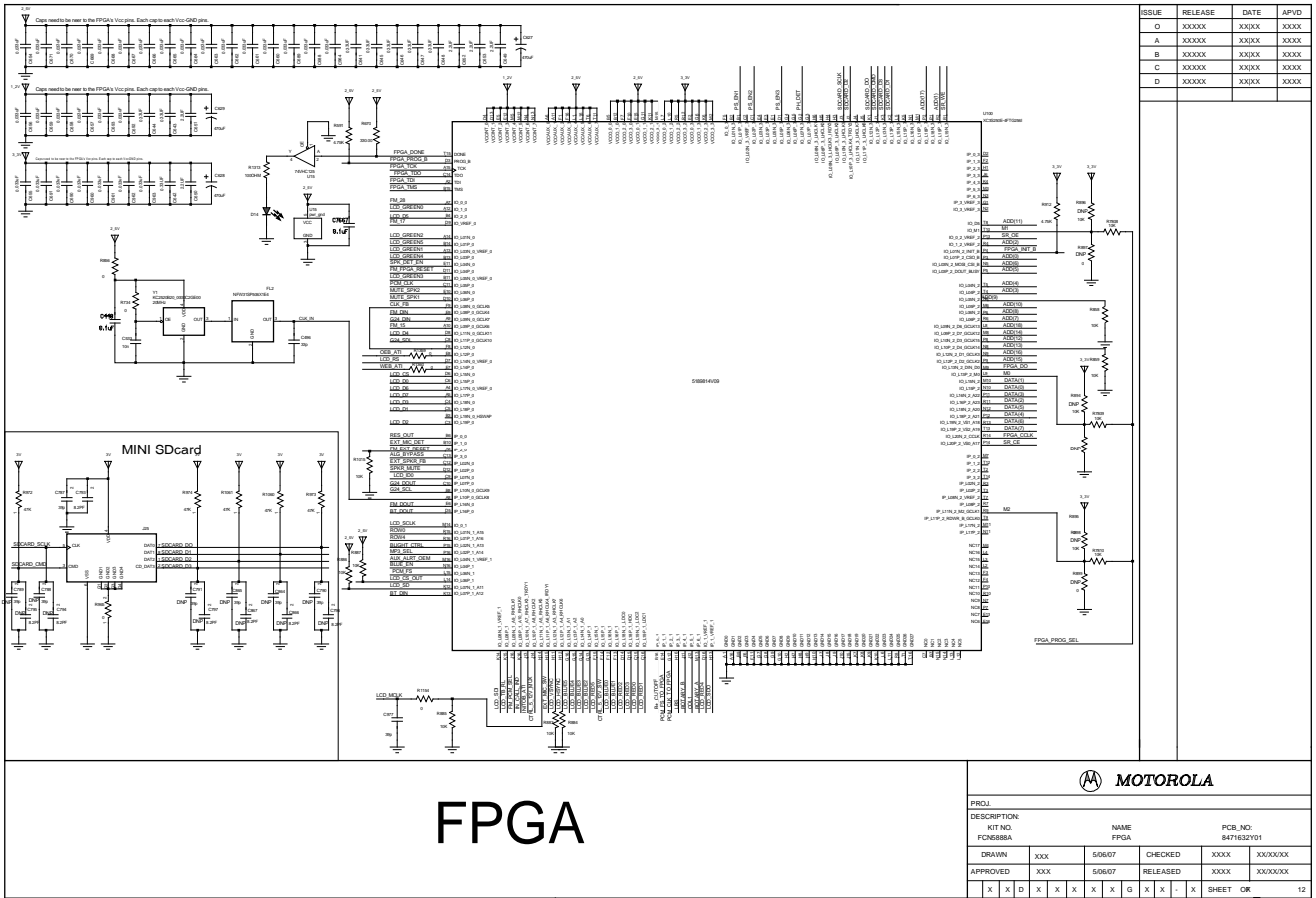

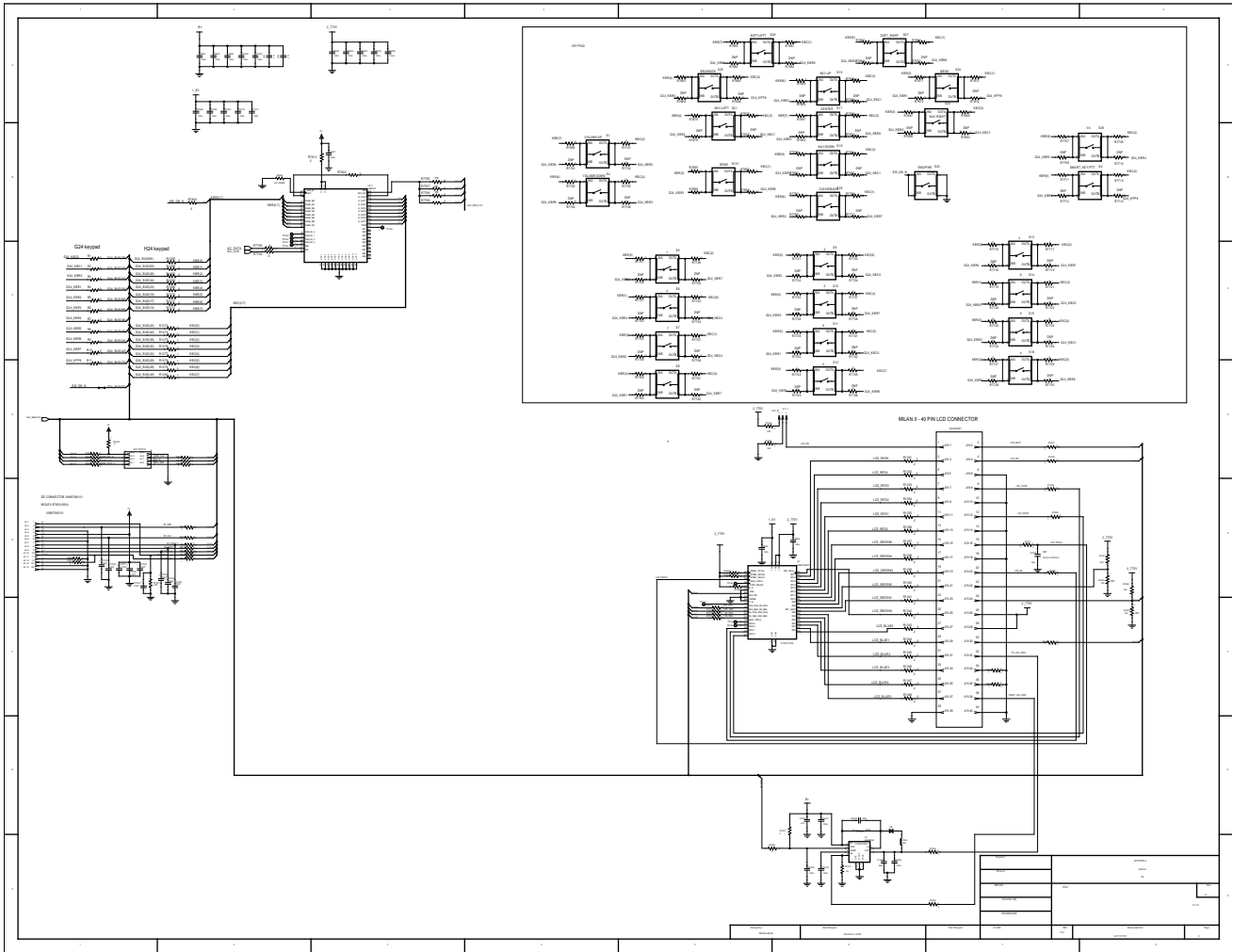

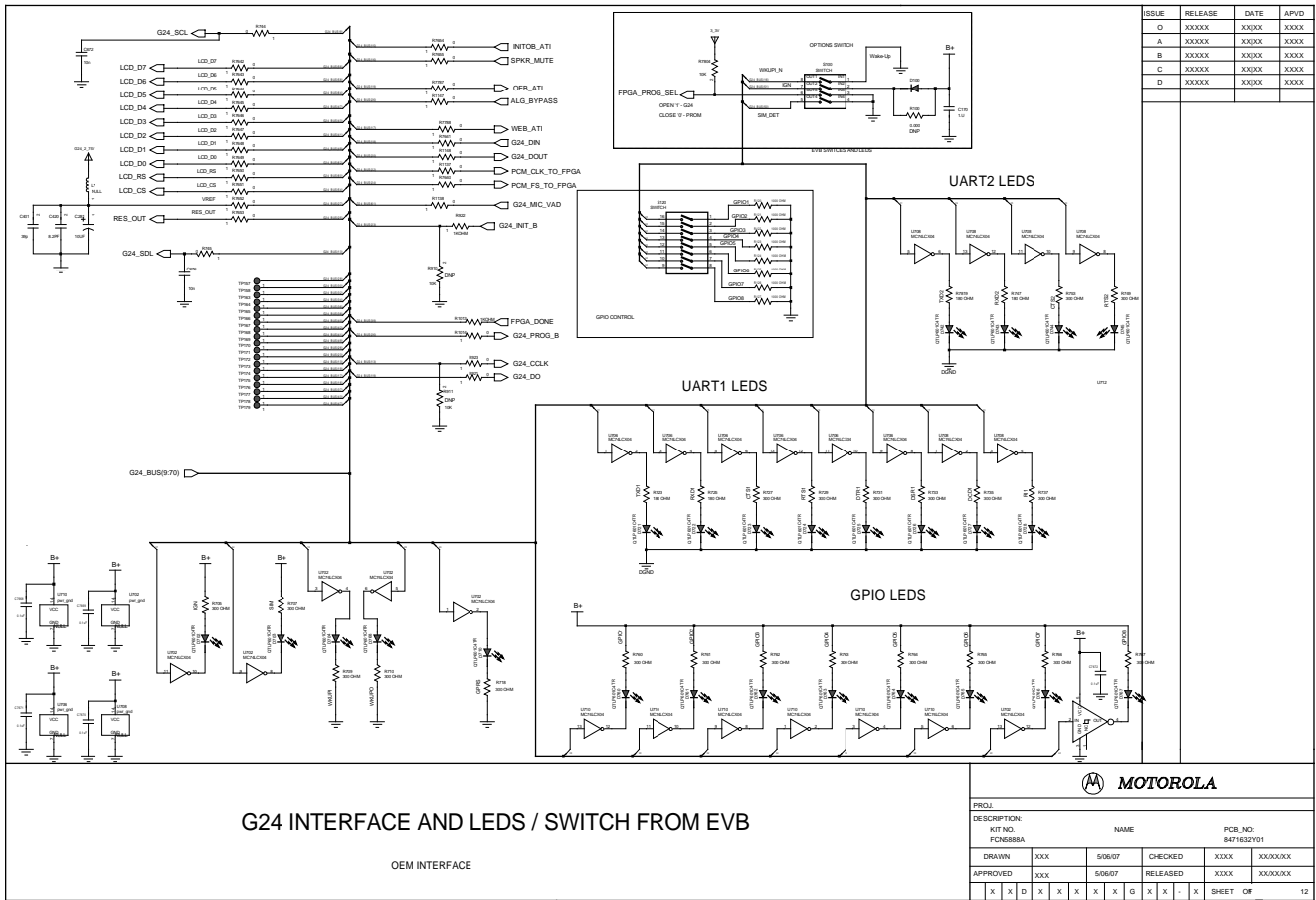

ISSUE	RELEASE	DATE	APVD
D	XXXXX	XXXX	XXXX
A	XXXXX	XXXX	XXXX
B	XXXXX	XXXX	XXXX
C	XXXXX	XXXX	XXXX
D	XXXXX	XXXX	XXXX

G24 INTERFACE AND LEDs / SWITCH FROM EVB

OEM INTERFACE

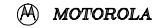

PROJ:					
DESCRIPTION:					
KIT NO.		NAME		PCB NO.	
FCN688BA				8471632Y01	
DRAWN	xxx	5/06/07	CHECKED	xxxx	xxxxxxx
APPROVED	xxx	5/06/07	RELEASED	xxxx	xxxxxxx
X	X	D	X	X	X
X	X	X	X	G	X
X	X	X	X	X	X
					SHEET OF 12

# CHAPTER 3 - HARDWARE SPECIFICATIONS

**40 PIN LCD CONNECTOR AND 40 PIN TEST CONNECTOR**

ISSUE	RELEASE	DATE	APVD
O	XXXXXX	XXXX	XXXX
A	XXXXXX	XXXX	XXXX
B	XXXXXX	XXXX	XXXX
C	XXXXXX	XXXX	XXXX
D	XXXXXX	XXXX	XXXX

## LCDS CONNECTORS

<b>MOTOROLA</b>					
PRG1: H24/G24 DISPLAY BOARD					
DESCRIPTION:		NAME:		PCB. JNO:	
KIT NO.:				B471757Y01	
DRAWN	XXX	5/5/67	CHECKED	XXXX	XXXXXX
APPROVED	XXX	5/5/67	RELEASED	XXXX	XXXXXX
X	X	D	X	X	X
X	X	X	X	X	G
X	X	X	X	X	X
X	X	X	X	X	X
				SHEET	OF 12



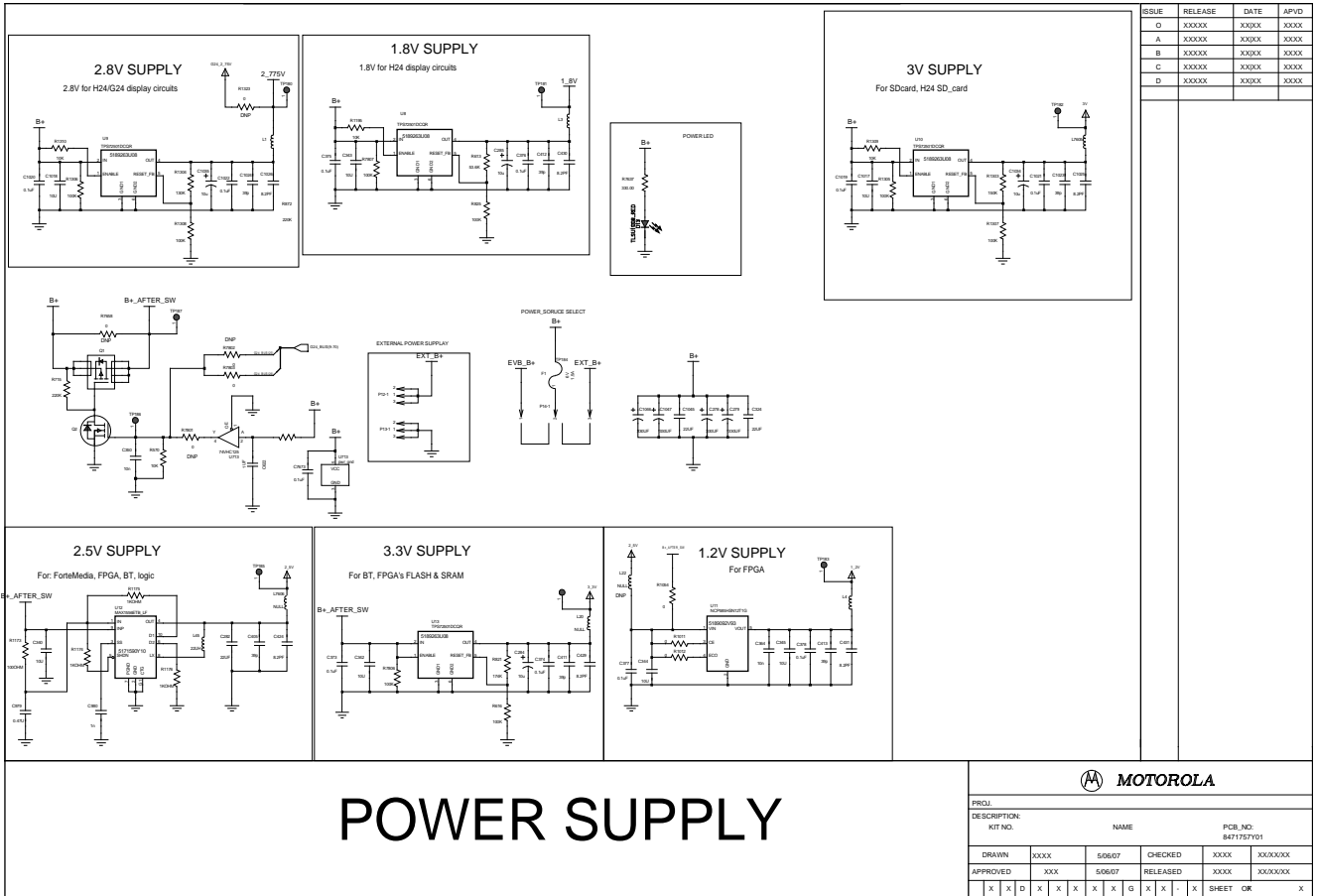

ISSUE	RELEASE	DATE	APVD
O	XXXXX	XXXXX	XXXXX
A	XXXXX	XXXXX	XXXXX
B	XXXXX	XXXXX	XXXXX
C	XXXXX	XXXXX	XXXXX
D	XXXXX	XXXXX	XXXXX

# POWER SUPPLY



PRJ: /									
DESCRIPTION: /									
KIT NO: /			NAME: /				PCB_NO: /		
DRAWN: /			506/07			CHECKED: /		XXXX /	
APPROVED: /			506/07			RELEASED: /		XXXX /	
X	X	D	X	X	X	X	X	X	X
								SHEET	OK

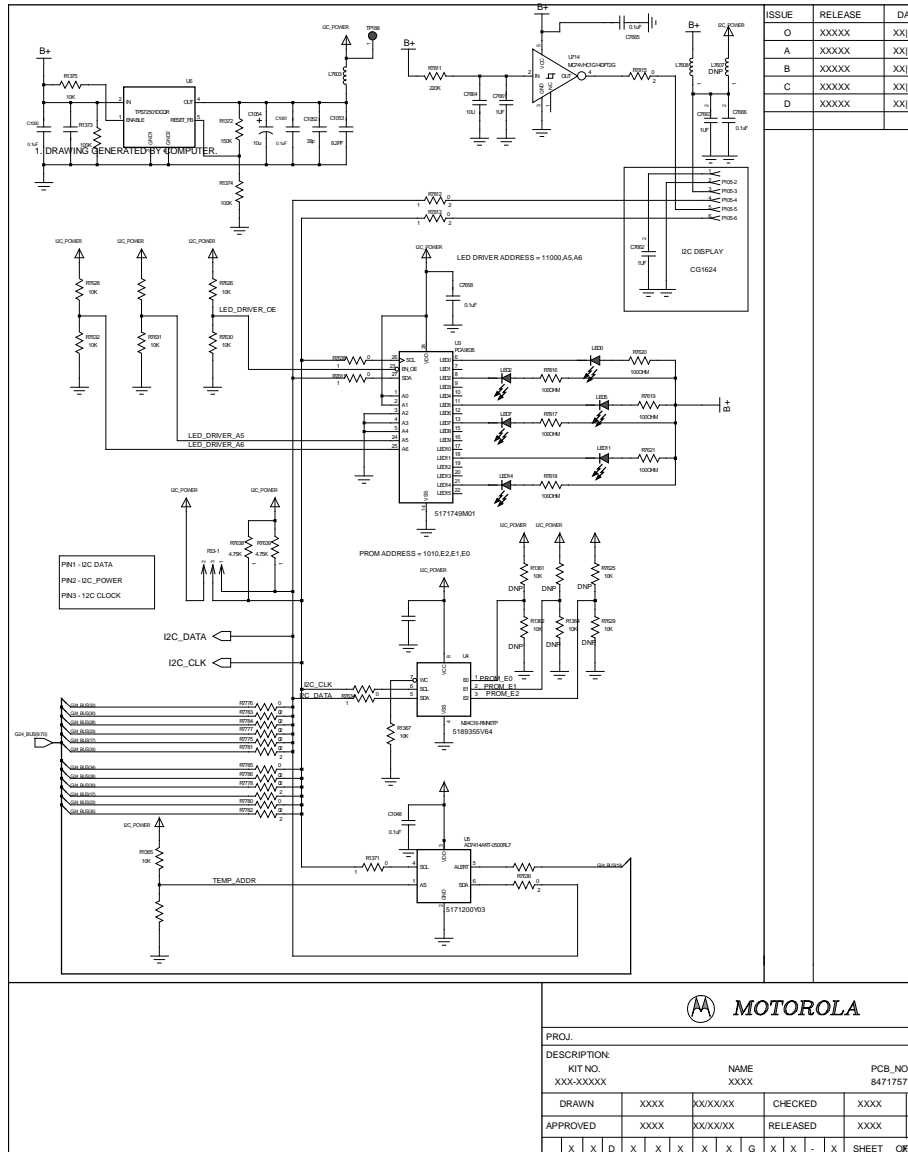

### 3.7 GPIO AVAILABILITY IN G24-J HMI

Four GPIOs are available for the GPIO API (package com.motorola.oem.hapi):

- GPIO 15
- GPIO 12, GPIO 13, GPIO 14 - Available after FPGA programming is done (see “Connecting the GPIOs for FPGA Programming”)

For further details about GPIO API, refer to [1].

# CHAPTER 4 - SOFTWARE SPECIFICATIONS

---

---

---

---

---

---

---

---

---

---

---

## 4.1 GENERAL

The display & keypad operations are managed by standard Java ME GUI libraries (javax.microedition.lcdui). Motorola proprietary Java interface is provided for FPGA & display configuration.



**Note**

For detailed package usage information refer to Javadoc (com.motorola.oem.osc package). See reference [2].

## 4.2 MOTOROLA PROPRIETARY JAVA INTERFACE FOR FPGA & DISPLAY CONFIGURATION

The DisplayConfig class configures and controls the main display FPGA settings. It is part of package com.motorola.oem.osc. It allows the following operations:

- FPGA programming (Available when **S100 switch 3** is set to "OFF", see "FPGA Programming" on page 10)
- G24-J Output Resolution
- FPGA & Display's manufacturer's commands

### 4.2.1 FPGA Programming Via UM

The configuration file is a resource in the UM jar file.

*DisplayConfig.loadFpgaConfigFile* loads the configuration file to the G24-J NVM. Then it is automatically loaded to the FPGA, upon each power up.

### 4.2.2 Resolution

*DisplayConfig.setDeviceOutputResolution* sets the G24-J output resolution.

Available resolutions are:

- 320x240 (Recommended)
- 220x176
- 160x128

All resolutions are available in portrait and landscape.

Default resolution of the G24-J: 320x240.



**Note**

The resolution selection should be coordinated with the FPGA supplier.

### 4.2.3 FPGA & Display Manufacturer Commands

*DisplayConfig.sendFpgaCommand* allows sending control commands to the FPGA or display.



The available commands are manufacturer dependent and will be detailed by the FPGA and/or display manufacturer.

**Note**

Possible commands are:

- Set rescaler algorithm:
  - Pixel duplication.
  - Linear interpolation.
  - Cubic interpolation.
  - Boosted cubic interpolation.
- Enable/Disable rotation (180 degrees)
- Power on/off

**Example:**

```
import com.motorola.oem.osc.DisplayConfig;
...
// Set rescaler algorithm to 'Boosted cubic interpolation'
DisplayConfig.sendFpgaCommand((byte)0x44);
```





MOTOROLA and the Stylized M Logo are registered in the US Patent & Trademark Office.

All other product or service names are the property of their respective owners.

©Copyright 2007 Motorola, Inc.

Java™ Technology and/or J2ME™ : Java and all other Java-based marks are trademarks or registered trademarks of Sun Microsystems, Inc. in the U.S. and other countries.

UNIX® : UNIX is a registered trademark of The Open Group in the United States and other countries.



**6802985C15-A**