

# SC872-A Product User Guide

1VV0301202 r1 – 2015-06-15



## APPLICABILITY TABLE

PRODUCT
SC872-A



*SPECIFICATIONS SUBJECT TO CHANGE WITHOUT NOTICE*

### **Notice**

While reasonable efforts have been made to assure the accuracy of this document, Telit assumes no liability resulting from any inaccuracies or omissions in this document, or from use of the information obtained herein. The information in this document has been carefully checked and is believed to be entirely reliable. However, no responsibility is assumed for inaccuracies or omissions. Telit reserves the right to make changes to any products described herein and reserves the right to revise this document and to make changes from time to time in content hereof with no obligation to notify any person of revisions or changes. Telit does not assume any liability arising out of the application or use of any product, software, or circuit described herein; neither does it convey license under its patent rights or the rights of others.

It is possible that this publication may contain references to, or information about Telit products (machines and programs), programming, or services that are not announced in your country. Such references or information must not be construed to mean that Telit intends to announce such Telit products, programming, or services in your country.

### **Copyrights**

This instruction manual and the Telit products described in this instruction manual may be, include or describe copyrighted Telit material, such as computer programs stored in semiconductor memories or other media. Laws in the Italy and other countries preserve for Telit and its licensors certain exclusive rights for copyrighted material, including the exclusive right to copy, reproduce in any form, distribute and make derivative works of the copyrighted material. Accordingly, any copyrighted material of Telit and its licensors contained herein or in the Telit products described in this instruction manual may not be copied, reproduced, distributed, merged or modified in any manner without the express written permission of Telit. Furthermore, the purchase of Telit products shall not be deemed to grant either directly or by implication, estoppel, or otherwise, any license under the copyrights, patents or patent applications of Telit, as arises by operation of law in the sale of a product.

### **Computer Software Copyrights**

The Telit and 3rd Party supplied Software (SW) products described in this instruction manual may include copyrighted Telit and other 3rd Party supplied computer programs stored in semiconductor memories or other media. Laws in the Italy and other countries preserve for Telit and other 3rd Party supplied SW certain exclusive rights for copyrighted computer programs, including the exclusive right to copy or reproduce in any form the copyrighted computer program. Accordingly, any copyrighted Telit or other 3rd Party supplied SW computer programs contained in the Telit products described in this instruction manual may not be copied (reverse engineered) or reproduced in any manner without the express written permission of Telit or the 3rd Party SW supplier. Furthermore, the purchase of Telit products shall not be deemed to grant either directly or by implication, estoppel, or otherwise, any license under the copyrights, patents or patent applications of Telit or other 3rd Party supplied SW, except for the normal non-exclusive, royalty free license to use that arises by operation of law in the sale of a product.



## Usage and Disclosure Restrictions

### License Agreements

The software described in this document is the property of Telit and its licensors. It is furnished by express license agreement only and may be used only in accordance with the terms of such an agreement.

### Copyrighted Materials

Software and documentation are copyrighted materials. Making unauthorized copies is prohibited by law. No part of the software or documentation may be reproduced, transmitted, transcribed, stored in a retrieval system, or translated into any language or computer language, in any form or by any means, without prior written permission of Telit

### High Risk Materials

Components, units, or third-party products used in the product described herein are NOT fault-tolerant and are NOT designed, manufactured, or intended for use as on-line control equipment in the following hazardous environments requiring fail-safe controls: the operation of Nuclear Facilities, Aircraft Navigation or Aircraft Communication Systems, Air Traffic Control, Life Support, or Weapons Systems (High Risk Activities"). Telit and its supplier(s) specifically disclaim any expressed or implied warranty of fitness for such High Risk Activities.

### Trademarks

TELIT and the Stylized T Logo are registered in Trademark Office. All other product or service names are the property of their respective owners.

### Third Party Rights

The software may include Third Party Right software. In this case you agree to comply with all terms and conditions imposed on you in respect of such separate software. In addition to Third Party Terms, the disclaimer of warranty and limitation of liability provisions in this License shall apply to the Third Party Right software.

TELIT HEREBY DISCLAIMS ANY AND ALL WARRANTIES EXPRESS OR IMPLIED FROM ANY THIRD PARTIES REGARDING ANY SEPARATE FILES, ANY THIRD PARTY MATERIALS INCLUDED IN THE SOFTWARE, ANY THIRD PARTY MATERIALS FROM WHICH THE SOFTWARE IS DERIVED (COLLECTIVELY "OTHER CODE"), AND THE USE OF ANY OR ALL THE OTHER CODE IN CONNECTION WITH THE SOFTWARE, INCLUDING (WITHOUT LIMITATION) ANY WARRANTIES OF SATISFACTORY QUALITY OR FITNESS FOR A PARTICULAR PURPOSE.

NO THIRD PARTY LICENSORS OF OTHER CODE SHALL HAVE ANY LIABILITY FOR ANY DIRECT, INDIRECT, INCIDENTAL, SPECIAL, EXEMPLARY, OR CONSEQUENTIAL DAMAGES (INCLUDING WITHOUT LIMITATION LOST PROFITS), HOWEVER CAUSED AND WHETHER MADE UNDER CONTRACT, TORT OR OTHER LEGAL THEORY, ARISING IN ANY WAY OUT OF THE USE OR DISTRIBUTION OF THE OTHER CODE OR THE EXERCISE OF ANY RIGHTS GRANTED UNDER EITHER OR BOTH THIS LICENSE AND THE LEGAL TERMS APPLICABLE TO ANY SEPARATE FILES, EVEN IF ADVISED OF THE POSSIBILITY OF SUCH DAMAGES.

Copyright © Telit Communications S.p.A. 2015.



## Contents

<b>1. Introduction.....</b>	<b>9</b>
1.1. Scope .....	9
1.2. Contact Information, Support .....	9
1.3. Text Conventions .....	9
1.4. Related Documents.....	9
<b>2. Product Description .....</b>	<b>10</b>
2.1. Product Overview.....	10
2.2. Block Diagram .....	11
2.3. Product Pictures .....	12
<b>3. Evaluation Kit.....</b>	<b>13</b>
<b>4. Product Features .....</b>	<b>15</b>
4.1. Static Navigation .....	15
4.2. Assisted GPS (AGPS) .....	15
4.2.1. Local AGPS – Embedded Assist System (EASY) .....	15
4.2.2. Server-based AGPS Extended Prediction Orbit (EPO).....	15
4.3. Satellite-Based Augmentation System (SBAS) .....	15
4.4. Quasi-Zenith Satellite System (QZSS).....	16
4.5. Jamming Rejection – Active Interference Cancellation (AIC) .....	16
4.6. Serial I/O Port .....	16
4.7. Power Management Modes .....	16
4.7.1. Full Power Continuous Mode.....	17
4.7.2. Standby Mode .....	17
4.7.3. Periodic Mode .....	17
4.7.4. AlwaysLocate™ Mode.....	18
<b>5. Product Specifications.....</b>	<b>19</b>
5.1. Performance Specifications .....	19
5.1.1. Horizontal Position Accuracy .....	19
5.1.2. Time to First Fix .....	20
5.1.3. Sensitivity.....	21



<b>6. Software Interface .....</b>	<b>22</b>
6.1. NMEA Output Messages .....	22
6.1.1. Standard Messages .....	22
6.1.2. Proprietary Messages .....	23
6.2. NMEA Input Commands .....	23
6.2.1. Commands Description .....	24
<b>7. Flash Upgradability .....</b>	<b>25</b>
<b>8. Electrical Interface .....</b>	<b>26</b>
8.1. Module Pin-out .....	26
8.2. Power Supply .....	27
8.2.1. Current Consumption .....	27
8.3. Digital Signal Interface .....	28
8.3.1. Logic Levels .....	28
8.3.2. TX .....	28
8.3.3. RX .....	28
8.4. RF Front End .....	29
8.4.1. Built-in Antenna .....	29
8.4.2. Frequency Plan .....	29
<b>9. Reference Design .....</b>	<b>30</b>
9.1. Pin Connections .....	30
9.2. Ground Plane .....	31
<b>10. Mechanical Drawing .....</b>	<b>32</b>
<b>11. Product Packaging and Handling .....</b>	<b>33</b>
11.1. Product Marking and Serialization .....	33
11.2. Product Packaging and Delivery .....	34
11.3. Moisture Sensitivity .....	35
11.4. ESD Sensitivity .....	36
11.5. Safety .....	36
11.6. Disposal .....	36
<b>12. Environmental Requirements .....</b>	<b>37</b>





- 12.1. Operating ..... 37
- 12.2. Storage ..... 37
- 13. Compliances ..... 38
  - 13.1. CE Declaration of Conformity ..... 39
  - 13.2. RoHS Certificate..... 40
- 14. Glossary and Acronyms ..... 41
- 15. Safety Recommendations..... 44
- 16. Document History ..... 45



## Figures

<b>Figure 2-1 SC872-A Block Diagram</b> .....	11
Figure 2-2 SC872-A Product Pictures .....	12
<b>Figure 3-1 SC872-A Evaluation Kit</b> .....	13
<b>Figure 3-2 EVK Smart Antenna</b> .....	14
<b>Figure 8-1 SC872-A Module Pinout</b> .....	26
<b>Figure 9-1 SC872-A Reference Design</b> .....	30
<b>Figure 9-2 Recommended Ground Plane</b> .....	31
<b>Figure 10-1 SC872-A Mechanical Drawing</b> .....	32
<b>Figure 11-1 SC872-A Label sample picture</b> .....	33
<b>Figure 11-3 Tray Packaging</b> .....	34
<b>Figure 11-4 Label for Moisture Sensitive Devices</b> .....	35

## Tables

<b>Table 5-1 SC872-A Position Accuracy</b> .....	19
<b>Table 5-2 SC872-A Time to First Fix</b> .....	20
<b>Table 5-3 SC872-A Receiver Sensitivity</b> .....	21
<b>Table 6-1 Default NMEA output messages</b> .....	22
<b>Table 6-2 NMEA Talker IDs</b> .....	23
<b>Table 6-3 NMEA Input Commands</b> .....	24
<b>Table 8-1 SC872-A Power Consumption</b> .....	27
<b>Table 8-2 Logic Level Electrical Characteristics</b> .....	28
<b>Table 8-3 Antenna Specifications</b> .....	29
<b>Table 8-4 Frequency Plan</b> .....	29
<b>Table 12-1 Operating Environmental Limits</b> .....	37
<b>Table 12-2 Storage Environmental Limits</b> .....	37





## 1. Introduction

### 1.1. Scope

This document provides product information for the SC872-A GNSS module.

### 1.2. Contact Information, Support

For general contact, technical support, to report documentation errors and to order manuals, contact Telit Technical Support Center (TTSC) at:

[TS-EMEA@telit.com](mailto:TS-EMEA@telit.com)

[TS-AMERICAS@telit.com](mailto:TS-AMERICAS@telit.com)

[TS-APAC@telit.com](mailto:TS-APAC@telit.com)

Alternatively, use:

<http://www.telit.com/en/products/technical-support-center/contact.php>

For detailed information about where you can buy the Telit modules or for recommendations on accessories and components visit:

<http://www.telit.com>

To register for product news and announcements or for product questions contact Telit Technical Support Center (TTSC).

Our aim is to make this guide as helpful as possible. Keep us informed of your comments and suggestions for improvements.

Telit appreciates feedback from the users of our information.

### 1.3. Text Conventions

All dates are in ISO 8601 format, i.e. YYYY-MM-DD.



***Danger – This information MUST be followed or catastrophic equipment failure or bodily injury may occur.***



***Caution or Warning – Alerts the user to important points about integrating the module, if these points are not followed, the module or end user equipment may fail or malfunction.***



**Tip or Information – Provides advice and suggestions that may be useful when integrating the module.**

### 1.4. Related Documents

- SC872-A Evaluation Kit User Guide
- MT GNSS Software User Guide
- MT GNSS Authorized Software User Guide



## 2. Product Description

The SC872-A is an integrated GNSS antenna receiver module using a state of the art GNSS engine.

The receiver can search and track satellite signals from the spectrum of GNSS constellations available: GPS (and Galileo as optional), Glonass, Beidou, QZSS and SBAS. However, the antenna is designed for the GPS and GLONASS bands. Therefore, a wider bandwidth antenna should be used to verify BeiDou.

Communication is performed over a TTL UART serial port using the NMEA-0183 protocol.

### 2.1. Product Overview

- Complete high-sensitivity GNSS receiver module including antenna, LNA, SAW filter, flash memory, TCXO, and RTC
- Based on the Mediatek MT3333 (with ARM7 core)
- 99 search channels and 33 simultaneous tracking channels
- GPS (L1), QZSS, and Glonass (L1), Galileo (E1) signals
- SBAS capable (WAAS, EGNOS, MSAS, GAGAN)
- AGPS support for extended ephemeris using local or server-based solutions: Embedded Assist System (EASY) or Extended Prediction Orbit (EPO)
- Jamming Rejection - Active Interference Cancellation
- Default 1 Hz reporting, Max 5 Hz (10 Hz with limitations)
- NMEA command input and data output
- Standard TTL UART serial port
- 8 Megabit built-in flash
- Less than 90 mW total power consumption (typical)
- Power management modes for extended battery life
- Supported by evaluation kits
- -20°C to +60°C operating temperature range
- RoHS compliant design



## 2.2. Block Diagram

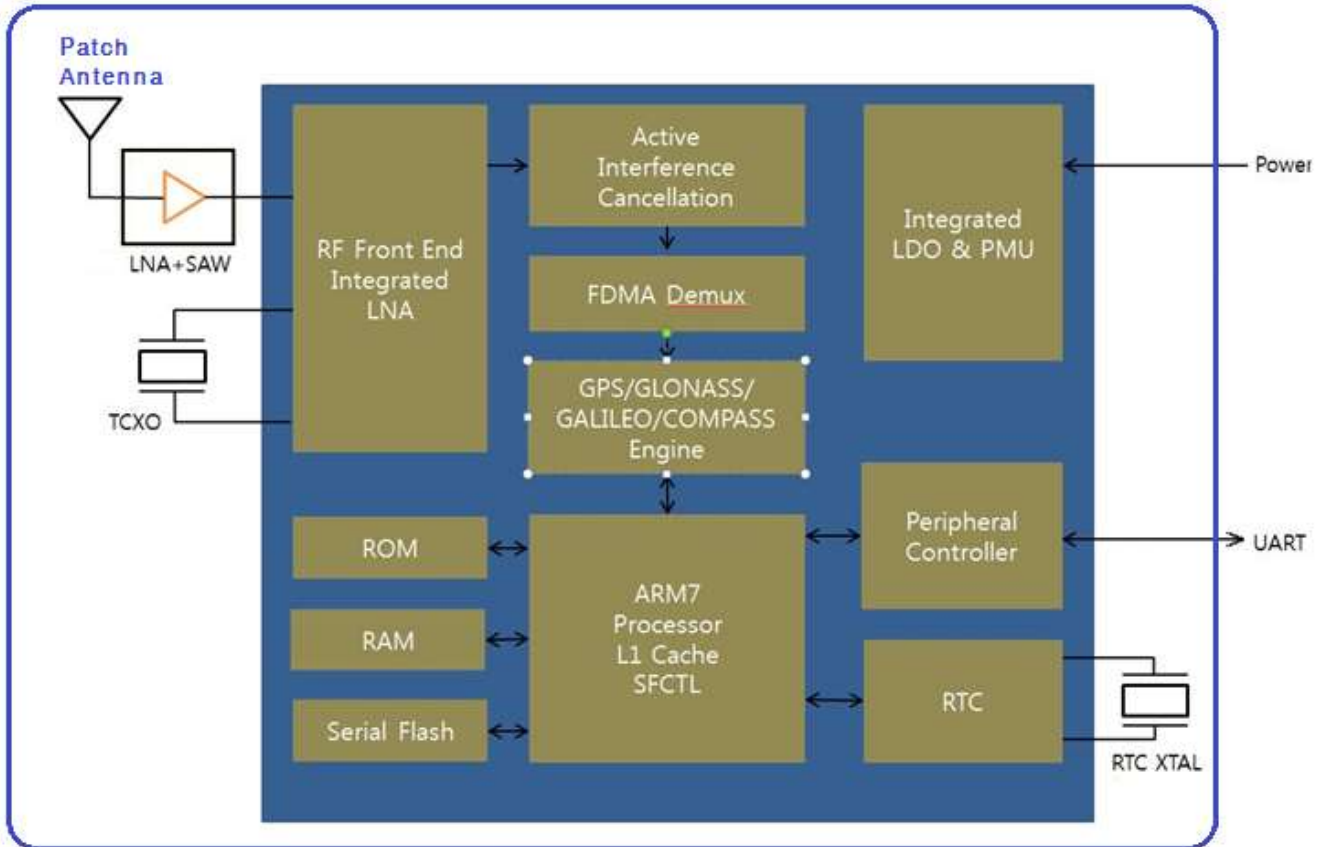

**Figure Error! No text of specified style in document.-1 SC872-A Block Diagram**



## 2.3. Product Pictures



**Figure Error! No text of specified style in document**  
**Product Pictures**



### 3. Evaluation Kit

The SC872-A Evaluation Kit (EVK) is available to assist in the evaluation and integration of the receiver module in custom applications. The EVK contains all of the necessary hardware and software to complete an evaluation of the module.



**Figure Error! No text of specified style in document.-3 SC872-A Evaluation Kit**





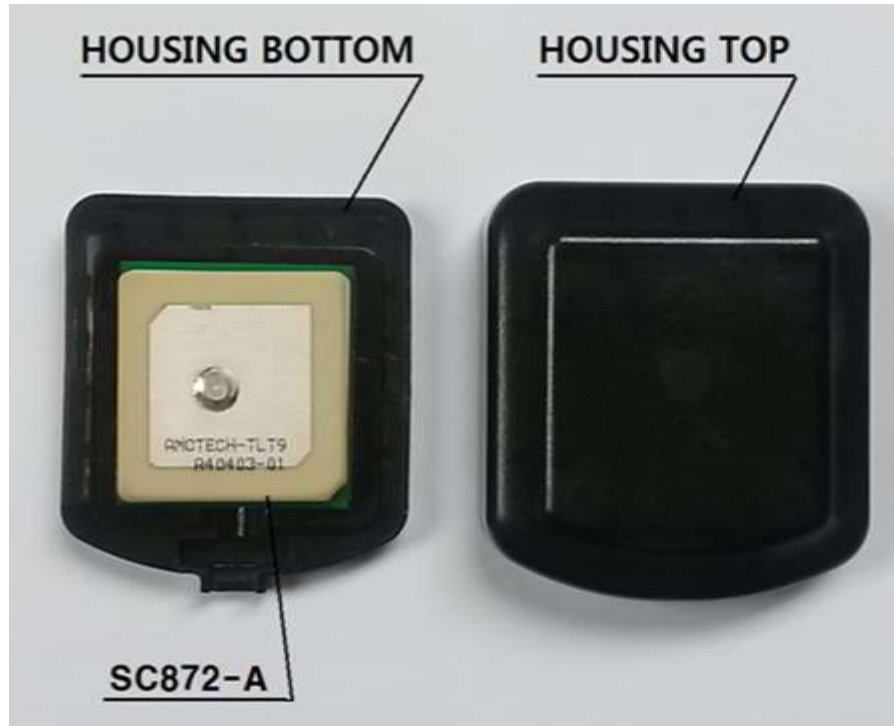

**Figure Error! No text of specified style in document.-4 EVK Smart Antenna**





## 4. Product Features

### 4.1. Static Navigation

Static Navigation is an operational mode in which the receiver will freeze the position fix when the speed falls below a set threshold (indicating that the receiver is stationary). The course is also frozen, and the speed is reported as 0. The navigation solution is unfrozen when the speed increases above a threshold or when the computed position exceeds a set distance from the frozen position (indicating that the receiver is again in motion). The speed threshold can be set via a command.

Static Navigation is disabled by default, but can be enabled by command. This feature is useful for applications in which very low dynamics are not expected, the classic example being an automotive application.

### 4.2. Assisted GPS (AGPS)

Assisted GPS (or Aided GPS) is a method by which TTFF is reduced using information from a source other than broadcast GPS signals. There are two sources of predicted ephemeris – locally predicted ephemeris and server-based predicted ephemeris data

#### 4.2.1. Local AGPS – Embedded Assist System (EASY)

Proprietary algorithms within the module perform ephemeris prediction locally from broadcast ephemeris data (received from tracked satellites). The algorithms predict ephemeris for up to three days.

#### 4.2.2. Server-based AGPS Extended Prediction Orbit (EPO)

The SC872-A supports server-based AGPS as a standard feature. Contact TELIT for support regarding this service.

Server-based ephemeris predictions are generated by a third party and are maintained on Telit AGPS servers in a file. The predicted ephemeris file is obtained from the AGPS server and is injected into the module over the serial port. These predictions do not require local broadcast ephemeris collection, and they are valid for up to 14 days.

### 4.3. Satellite-Based Augmentation System (SBAS)

The receiver is capable of using Satellite-Based Augmentation System (SBAS) satellites as a source of both differential corrections and satellite range measurements. These systems (WAAS, EGNOS, MSAS, and GAGAN) use geostationary satellites to transmit regional differential corrections via a GNSS-compatible signal. The use of SBAS corrections can significantly improve typical position accuracy. SBAS is enabled by default.



#### 4.4. Quasi-Zenith Satellite System (QZSS)

The three satellites of the Japanese SBAS are in a highly-inclined elliptical orbit which is geosynchronous (not geostationary) and has analemma-like ground tracks. This orbit allows continuous coverage over Japan using only three satellites. Their primary purpose is to provide augmentation to the GPS system, but the signals may also be used for ranging. NMEA reporting for QZSS may be enabled/disabled by the user.

#### 4.5. Jamming Rejection – Active Interference Cancellation (AIC)

The SC872-A detects, tracks and removes narrow-band interfering signals (jamming signals) without the need for external components or tuning. It tracks and removes up to 12 CW (Continuous Wave) type signals up to  $-80$  dBm (total power signal levels). By default, the jamming detection is disabled but can be enabled by command. This feature is useful both in the design stage and during the production stage for uncovering issues related to unexpected jamming. When enabled, Jamming Rejection will increase current drain by about 1 mA. Impact on GNSS performance is low at modest jamming levels. However, at high jamming levels (e.g.  $-90$  to  $-80$  dBm), the RF signal sampling ADC starts to become saturated after which the GNSS signal levels start to decrease.

Jamming Rejection is effective against narrow band clock harmonics. It is not effective against wide band noise, e.g. from a host CPU memory bus or switching power supply because these sources typically cannot be distinguished from thermal noise. A wide band jamming signal effectively increases the noise floor and reduces GNSS signal levels.

#### 4.6. Serial I/O Port

The SC872-A module includes a full-duplex Universal Asynchronous Receiver Transmitter (UART) serial interface that supports configurable baud rates. The signal output and input levels are LVTTTL compatible. Note that the idle state of the interface lines is logic high.

#### 4.7. Power Management Modes

The SC872-A module supports operational modes that allow it to provide positioning information at reduced overall current consumption.

Availability of GNSS signals in the operational environment will be a factor in choosing power management modes. The designer can choose a mode that provides the best tradeoff of navigation performance versus power consumption.

The power management modes can be enabled by sending the desired command using the host serial port (RX).



### 4.7.1. Full Power Continuous Mode

The SC872-A module powers up directly into full power continuous mode. Continuous mode uses the acquisition engine at full performance resulting in the shortest possible TTFF and the highest sensitivity. It searches for all possible satellites. The receiver switches to the tracking engine to lower the power consumption when:

- A valid GPS/GNSS position is obtained
- The ephemeris for each satellite in view is valid

The user can return to Full Power mode from a low power mode by sending the following

NMEA command:

**\$PMTK225,0\*2B**

just after the module wakes up from its previous sleep cycle.

If power is removed from both Vcc and Vbatt, then Time, Ephemeris, Almanac, EASY data, EPO data, and PMTK configuration will be lost. If Vbatt is maintained, no data will be lost.

### 4.7.2. Standby Mode

In this mode, the receiver stops navigation, the internal processor enters standby state, and the current drain at main supply VCC is reduced.

Standby mode is entered by the PMTK command:

**\$PMTK161,0\*28**

The host can then wake up the module from Standby mode to Full Power mode by sending any byte via the host port.

### 4.7.3. Periodic Mode

This mode allows autonomous power on/off, with reduced fix rate, to reduce average power consumption. The main power supply VCC is still powered, but power distribution to internal circuits is controlled by the receiver.

Enter periodic mode by sending the following command:

**\$PMTK225,<Type>,<Run\_time>,<Sleep\_time>,<2nd\_run\_time>,<2nd\_sleep\_time>\*<checksum>**

Where:

Type = 1 for Periodic mode

Run\_time = Full Power period (ms)

Sleep\_time = Standby period (ms)

2nd\_run\_time = Full Power period (ms) for extended acquisition if GNSS acquisition fails during Run\_time

2nd\_sleep\_time = Standby period (ms) for extended sleep if GNSS acquisition fails during Run\_time



Example: **\$PMTK225,1,3000,12000,18000,72000\*16**  
for periodic mode with 3 s navigation and 12 s sleep in backup state.

The acknowledgement response for the command is:  
**\$PMTK001,225,3\*35**

Periodic mode is exited by sending the command  
**\$PMTK225,0\*2B**  
just after the module wakes up from a previous sleep cycle.

#### 4.7.4. AlwaysLocate™ Mode

AlwaysLocate™ is an intelligent controller of the Periodic mode. The main power supply VCC is powered, but distribution is internally controlled. Depending on the environment and motion conditions, the module can autonomously and adaptively adjust the parameters of the Periodic mode, e.g. ON/OFF ratio and fix rate in order to achieve a balance in positioning accuracy and power consumption. The average current can vary based on conditions.

Enter AlwaysLocate™ mode by sending the following NMEA command:  
**\$PMTK225,<mode>\*<checksum><CR><LF>**

Where:  
Mode = 9 for AlwaysLocate™ in Backup mode.

Example: **\$PMTK225,9\*22**

The acknowledgement response for the command is:  
**\$PMTK001,225,3\*35.**

The user can exit low power modes to Full Power by sending NMEA command:  
**\$PMTK225,0\*2B**  
just after the module wakes up from its previous sleep cycle.



## 5. Product Specifications

### 5.1. Performance Specifications

#### 5.1.1. Horizontal Position Accuracy

Constellation	CEP (m)
GPS	2.6
Glonass	2.6
GPS + Glonass	2.6

Test Conditions: 24 hr. static, -130 dBm, Full Power mode

**Table Error! No text of specified style in document.-1 SC872-A Position Accuracy**



### 5.1.2. Time to First Fix

Constellation	Start Type	Max TTFF (s)
GPS	Hot	1.0
	Warm	35
	Cold	35
Glonass	Hot	1.0
	Warm	28
	Cold	29
GPS + GLO	Hot	1.0
	Warm	26
	Cold	27

Test Conditions: Internal LNA used GNSS radiating antenna at 50cm distance.  
NOTE: The above performance values were achieved under ideal lab conditions using a GNSS Simulator.

**Table Error! No text of specified style in document.-2 SC872-A Time to First Fix**





### 5.1.3. Sensitivity

Constellation	State	Signal Level (dBm)
GPS	Acquisition	-146
	Navigation	-156
	Tracking	-157
Glonass	Acquisition	-143
	Navigation	-153
	Tracking	-157
GPS + GLO	Acquisition	-145 / -143
	Navigation	-156 / -153
	Tracking	-157 / -156
Test Conditions: Internal LNA used GNSS radiating antenna at 50cm distance. NOTE: The above performance values were achieved under ideal lab conditions using a GNSS Simulator.		

**Table Error! No text of specified style in document.-3 SC872-A Receiver Sensitivity**



## 6. Software Interface

The host serial I/O port (RX and TX pins) supports full duplex communication between the receiver and the user.

The default serial configuration is: NMEA, 9600 bps, 8 data bits, no parity, 1 stop bit.



More information regarding the software interface can be found in the Software User Guide. Customers that have executed a Non-Disclosure Agreement (NDA) with Telit Wireless may obtain the Authorized Software User Guide, which contains additional proprietary information.

### 6.1. NMEA Output Messages



In the current Firmware release, some sentences may exceed the NMEA length limitation of 80 characters.

By default, GPS and QZSS constellations are enabled.

The default fix rate is 1 Hz.

The following messages are output by default.

Multiple GSA and GSV messages may be output on each cycle.

#### 6.1.1. Standard Messages

Message	Description	Default
RMC	GNSS Recommended minimum navigation data	On
GGA	GNSS position fix data	On
VTG	Course Over Ground & Ground Speed	On
GSA	GNSS Dilution of Precision (DOP) and active satellites	On
GSV	GNSS satellites in view.	On
\$PMTK010	System messages (e.g. to report startup, etc.)	On
GLL	Geographic Position – Latitude & Longitude	Off
ZDA	Time & Date	Off

**Table Error! No text of specified style in document.-4 Default NMEA output messages**



Talker ID	Constellation
BD	BeiDou
GA	Galileo
GL	GLONASS
GP	GPS
QZ	QZSS

Table Error! No text of specified style in document.-5 NMEA Talker IDs

### 6.1.2. Proprietary Messages

The SC872-A supports several proprietary NMEA periodic output messages which report additional receiver data and status information

## 6.2. NMEA Input Commands

The SC872-A uses NMEA proprietary messages for commands and command responses. This interface provides configuration and control over selected firmware features and operational properties of the module.

The format of a command is:

```
$<command-ID>[ ,<parameters>] *<cr><lf>
```

Commands are NMEA proprietary format and begin with “\$PMTK”. Parameters, if present, are comma-delimited as specified in the NMEA protocol.

Unless otherwise noted in the Software User Guide, commands are echoed back to the user after the command is executed.



## 6.2.1. Commands Description

Command ID	Description
\$PMTK000	Test. This command will be echoed back to the sender (for testing the communications link).
\$PMTK101	Perform a HOT start
\$PMTK102	Perform a WARM start
\$PMTK103	Perform a COLD start
\$PMTK104	Perform a system reset (erasing any stored almanac data) and then a COLD start
\$PMTK120	Erase aiding data stored in flash memory
\$PMTK127	Erase EPO data stored in flash memory
\$PMTK161,0	Standby - Stop mode
\$PMTK161,1	Standby - Sleep mode
\$PMTK251,Baudrate	Set NMEA Baudrate
\$PMTK313,0	Disable SBAS feature
\$PMTK313,1	Enable SBAS feature
\$PMTK353,1,0,0,0,0	Enable GPS only mode
\$PMTK353,0,1,0,0,0	Enable GLO only mode
\$PMTK353,0,0,0,0,1	Enable BDS only mode
\$PMTK353,1,1,0,0,0	Enable GPS and GLO mode
\$PMTK353,1,0,0,0,1	Enable GPS and BDS mode

**Table Error! No text of specified style in document.-6 NMEA Input Commands**



## 7. Flash Upgradability

The firmware stored in the internal Flash memory may be upgraded via the serial port TX/RX pins. In order to update the FW, the following steps should be performed to perform re-programming of the module.

1. Remove all power to the module.
2. Connect serial port to a PC.
3. Apply main power.
4. Run the software utility to re-flash the module. Clearing the entire flash memory is strongly recommended prior to programming.
5. Upon successful completion of re-flashing, remove main power to the module for a minimum of 10 seconds.
6. Apply main power to the module.
7. Verify the module has returned to the normal operating state.



## 8. Electrical Interface

### 8.1. Module Pin-out

The host serial I/O port of the receiver's serial data interface supports full duplex communication between the receiver and the user.

The default serial configuration is: NMEA, 9600 bps, 8 data bits, no parity, and 1 stop bit.

I/O (Input / Output) & power connector: 1.25 mm (0.049") pitch, surface mount type

PN: 12505WR-04 in Yeonho Electronics Co., Ltd. [www.yeonho.com](http://www.yeonho.com)  
12505HS-04 Housing and 12505TS Terminal is the matching connector.

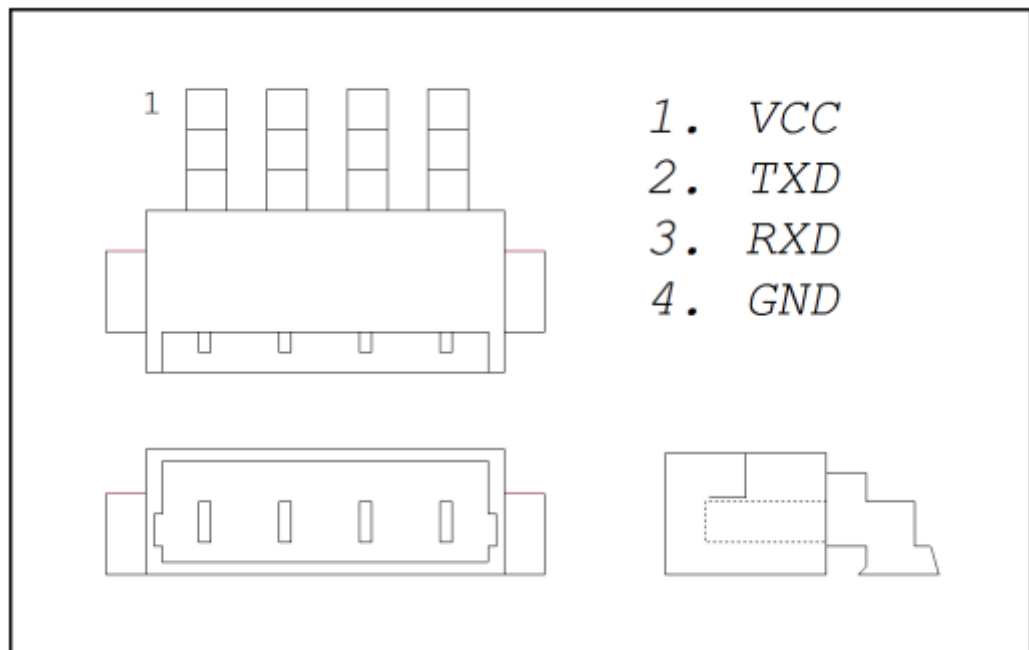

**Figure Error! No text of specified style in document.-5 SC872-A Module Pinout**





## 8.2. Power Supply

The SC872-A module VCC requires a 3.3 – 5.25V DC supply with absolute operating voltage 3.3 V min, 6.0 V max DC supply.

Power must be within specification within 10ms of initial application. Slower ramping may cause the module to fail to start up.

If the DC supply is removed, the receiver loses contents of the internal SRAM and current RTC time, therefore a cold start is required.

### 8.2.1. Current Consumption

State & Constellation	Symbol	Typ	Max	Unit
<b>Acquisition</b>				
GPS and Glonass	I <sub>cc</sub>	30	35	mA
GPS Only	I <sub>cc</sub>	30	35	mA
Glonass Only	I <sub>cc</sub>	25	30	mA
<b>Navigation/Tracking</b>				
GPS and Glonass	I <sub>cc</sub>	26	33	mA
GPS Only	I <sub>cc</sub>	24	34	mA
Glonass Only	I <sub>cc</sub>	26	34	mA
<b>Low Power Modes</b>				
GPS and Glonass Standby	I <sub>cc</sub>	4.5		mA
GPS Only Standby	I <sub>cc</sub>	4.5		mA
<b>Battery Backup</b>	I <sub>BATT</sub>	7		uA
Operating temperature: 25°C Supply voltage (nominal) 3.3 VDC Low Power configuration: 500 ms duty cycle Note: The above Periodic Mode results were achieved with the default settings of the receiver asleep for 12 sec, then awake for 3 sec. periodically.				

**Table Error! No text of specified style in document.-7 SC872-A Power Consumption**



## 8.3. Digital Signal Interface

### 8.3.1. Logic Levels

Logic levels used by the TX and RX interfaces of the SC872-A module are shown below:

Symbol	Parameter	Min.	Typ.	Max.	Unit
$V_{IL}$	Input low	-	-	0.77	V
$V_{IH}$	Input high	2.0	-	Vcc	V
$V_{OL}$	Output low	-	-	0.46	V
$V_{OH}$	Output high	2.14	-	-	V

**Table Error! No text of specified style in document.-8 Logic Level Electrical Characteristics**

### 8.3.2. TX

The TX data line outputs NMEA serial data at a default bit rate of 9600 bps from the module to the host.

When no serial data is being output the TX data line idles high.

### 8.3.3. RX

The RX data line accepts proprietary NMEA commands at a default bit rate of 9600 bps from the host CPU to the SC872-A module.

When the module is powered down, do not back drive it. The idle state for serial data from the host computer will be logic 1.



## 8.4. RF Front End

The SC872-A contains built-in RF front-end with integrated GPS antenna, LNA and SAW filter. No external antenna is supported.

### 8.4.1. Built-in Antenna

The integrated antenna is a 20 mm by 20 mm ceramic patch antenna.



In order to optimize antenna performances it is strongly recommended to design a 70 mm by 70 mm ground plane around the module into the application PCB.



*If the ground plane size is smaller than 70x70mm a center frequency detuning may occur.*

Parameter	GPS Specification
Center frequency	1575 to 1608 MHz (GPS: 1575, Glonass 1575 to 1608)
Return Loss @ center freq.	Min. 10 dB @ 1575 to 1602 MHz
Gain @ center freq.	GPS: Typ. -3.0 dB @ Zenith Glonass: Typ. -3.0 dB @ Zenith
Axial ratio	GPS: Typ. 8.0 Glonass: Typ. 12.0
Polarization	RHCP
Impedance	50 Ω

Table Error! No text of specified style in document.-9 Antenna Specifications

### 8.4.2. Frequency Plan

Signal	Frequency (MHz)
TCXO	16.368 (0.5 ppm)

Table Error! No text of specified style in document.-10 Frequency Plan



## 9. Reference Design

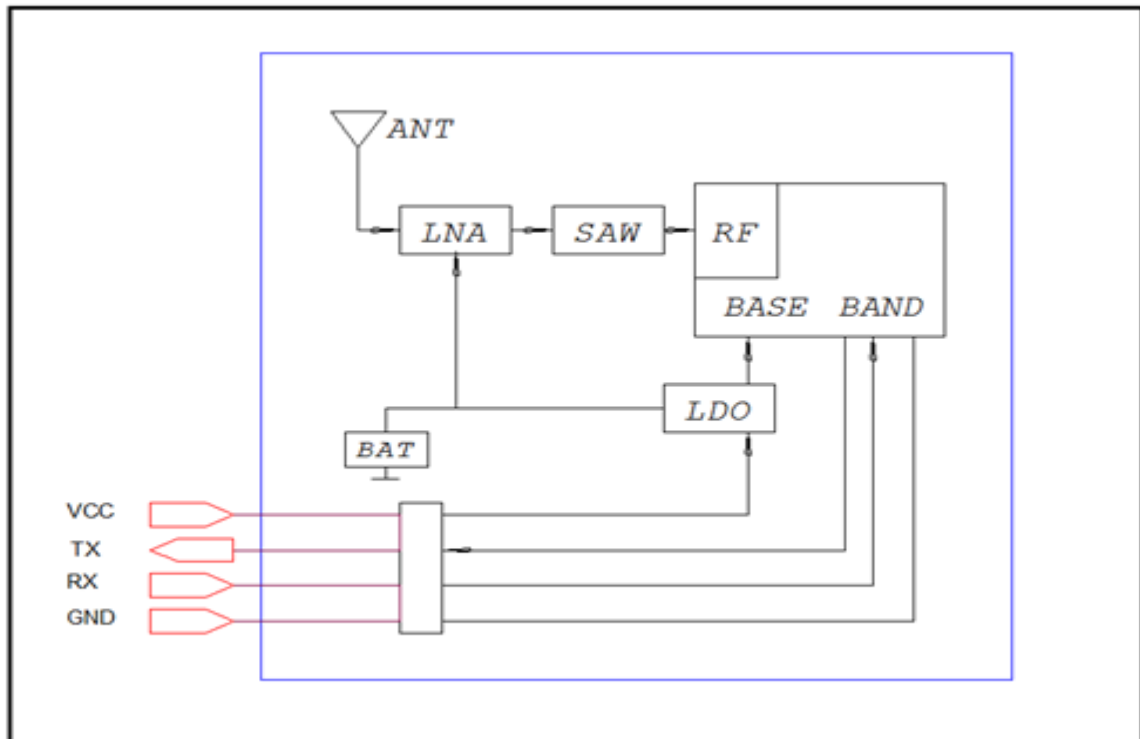

**Figure Error! No text of specified style in document.-6 SC872-A Reference Design**

The module includes a high-performance GNSS engine, LNA, and integrated SAW filter. A patch antenna is optimized for good performance.

### 9.1. Pin Connections

VCC: 0.1  $\mu$ F or higher by-pass cap connected to VCC is recommended.

TX: Connect a 33 to 100  $\Omega$  external resistor in series to minimize overshoot and undershoot

RX: Connect a 33 to 100  $\Omega$  external resistor in series to minimize overshoot and undershoot

GND: Connect to a stable ground

Cable: Use aluminum braid or foil shield and/or twisted conductors to minimize external noise.

## 9.2. Ground Plane

In order to optimize antenna performance, a 70mm by 70mm ground plane should be included on the PCB around the module as shown below.

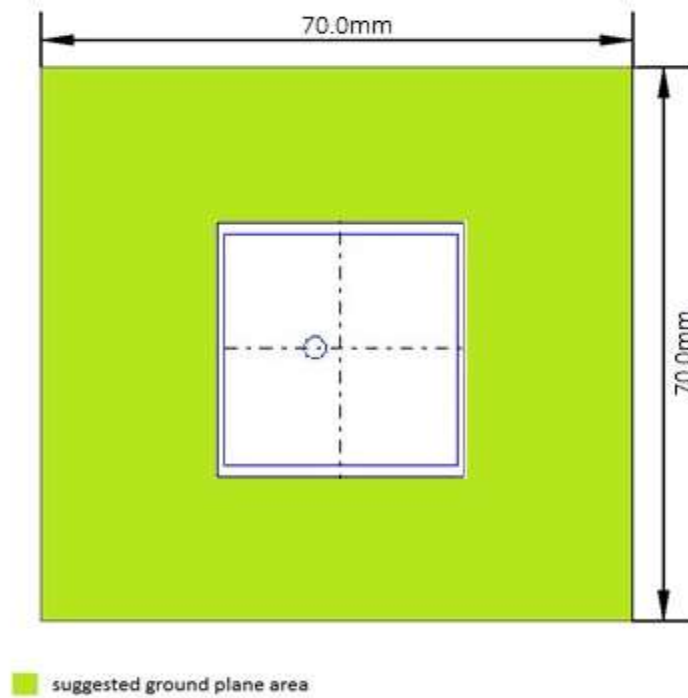

**Figure Error! No text of specified style in document.-7 Recommended Ground Plane**



## 10. Mechanical Drawing

The SC872-A module has advanced miniature packaging including a passive antenna with a base metal of copper and an Electro less Nickel Immersion Gold (ENIG) finish.

The SC872-A mechanical drawing and dimensions are shown below.

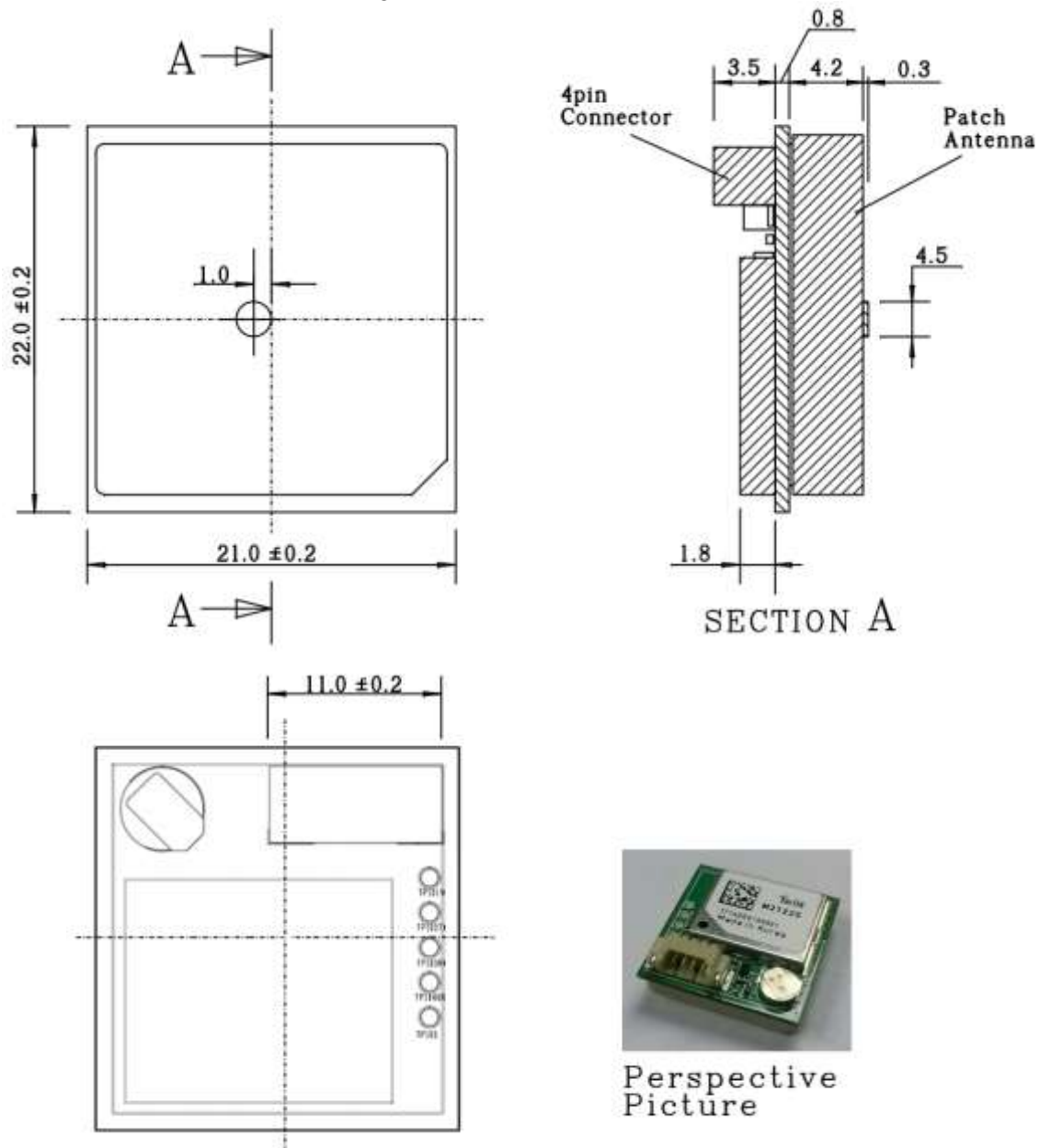

All dimensions are expressed in millimeters.

**Figure Error! No text of specified style in document.-8 SC872-A Mechanical Drawing**





## 11. Product Packaging and Handling

### 11.1. Product Marking and Serialization

The SC872-A module label has a 2D Barcode with the module serial number.  
Contact a Telit representative for information on specific module serial numbers.



**Figure Error! No text of specified style in document.-9 SC872-A Label sample picture**



## 11.2. Product Packaging and Delivery

SC872-A modules are shipped in trays. Each tray is ‘dry’ packaged and vacuum sealed in a Moisture Barrier Bag (MBB) with two silica gel packs and placed in a carton.

All packaging is ESD protective lined.

The SC872-A receivers are Moisture Sensitive Devices (MSD). Please follow the MSD and ESD handling instructions on the labels of the MBB and exterior carton.

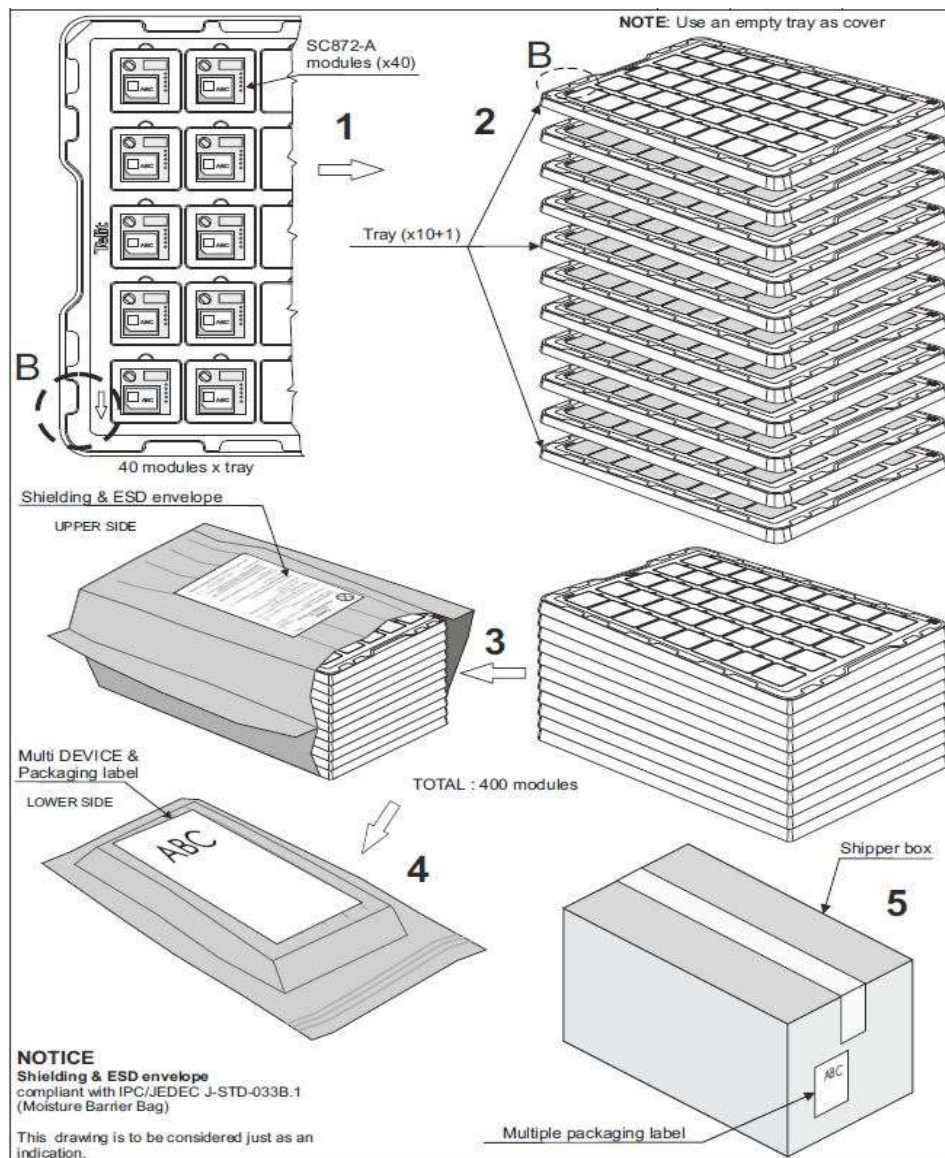

Figure Error! No text of specified style in document.-10 Tray Packaging

### 11.3. Moisture Sensitivity

Precautionary measures are required in handling, storing and using such devices to avoid damage from moisture absorption. If localized heating is required to rework or repair the device, precautionary methods are required to avoid exposure to solder reflow temperatures that can result in performance degradation.

The SC872-A has a moisture sensitivity level rating of 3 as defined by IPC/JEDEC J-STD-020. This rating is assigned due to some of the components used within the SC872-A.

The SC872-A modules are supplied in tape and reel and is hermetically sealed with desiccant and humidity indicator card. The SC872-A parts must be placed and reflowed within 168 hours of first opening the hermetic seal provided the factory conditions are less than 30°C and less than 60% and the humidity indicator card indicates less than 10% relative humidity.

If the package has been opened or the humidity indicator card indicates above 10%, then the parts will need to be baked prior to reflow. The parts may be baked at +60°C ± 5°C for 12 hours. However, the trays, nor the tape and reel can withstand that temperature. Lower temperature baking is feasible if the humidity level is low and time is available.

Please see IPC/JEDEC **J-STD-033** for additional information.

Additional information can be found on the MSL tag affixed to the outside of the hermetically sealed bag.



Figure Error! No text of specified style in document.-11 Label for Moisture Sensitive Devices



## 11.4. ESD Sensitivity

The SC872-A module contains class 1 devices and is Electro-Static Discharge Sensitive (ESDS).

Telit recommends the two basic principles of protecting ESD devices from damage:

- Handle sensitive components only in an ESD Protected Area (EPA) under protected and controlled conditions;
- Protect sensitive devices outside the EPA using ESD protective packaging.

All personnel handling ESDS devices have the responsibility to be aware of the ESD threat to the reliability of electronic products.

Further information can be obtained from the JEDEC standard **JESD625-A Requirements for Handling Electrostatic Discharge Sensitive (ESDS) Devices**.

## 11.5. Safety

Improper handling and use of this module can cause permanent damage to the receiver. There is also the possible risk of personal injury from mechanical trauma or choking hazard.

## 11.6. Disposal

We recommend that this product should not be treated as household waste. For more detailed information about recycling this product, please contact your local waste management authority or the reseller from whom you purchased the product.





## 12. Environmental Requirements

### 12.1. Operating

Temperature	-20°C to +60°C
Temperature Rate of Change	±1°C / minute maximum
Humidity	Up to 95% non-condensing or a wet bulb temperature of +35°C, whichever is less
Altitude	-1500 m to 100,000 m
Vibration	
Maximum Vehicle Dynamics	600 m/s (acquisition and navigation) 2G acceleration
ITAR Limits	515 m/s and altitude greater than 18,000 m

**Table Error! No text of specified style in document.-11 Operating Environmental Limits**

### 12.2. Storage

Temperature	-30°C to +70°C
Humidity	Up to 95% non-condensing or a wet bulb temperature of +35°C, whichever is less
Altitude	-1000 feet to 60,000 feet
Shock	18G peak, 5 millisecond duration
Shock (in shipping container)	10 drops from 75 cm onto concrete floor

**Table Error! No text of specified style in document.-12 Storage Environmental Limits**



## 13. Compliances

The SC872-A module complies with the following:

- Directive 2002/95/EC on the restriction of the use of certain hazardous substances in electrical and electronic equipment (RoHS)
- Manufactured in an ISO 9000: 2000 accredited facility
- Manufactured to TS 16949 requirement (upon request)

The SC872-A module conforms to the following European Union Directives:

- Low Voltage Directive 2006/95/EEC and product safety
- Directive EMC 2004/108/EC for conformity for EMC





## 13.1. CE Declaration of Conformity



# Expertise

Expert Opinion of the Notified Body on the Conformity Assessment  
according to Article 10.5 of R&TTE Directive 1999/5/EC

**PHOENIX TESTLAB**  
EU Identification Number 0700

Recognised by



BNWZA-BS-02/15-1-55

Expertise No.	14-117245a
Certificate Holder	Telit Wireless Solutions Co., Ltd.
Address	8th FL. Shinyoung Securities Bld., 6, Gukjegeumyung-ro8-gil, Yeongdeungpo-gu, Seoul, 150-884, Korea
Product Description	GNSS Antenna module, with GPS, Beidou and GLONASS
Brand Name / Model Name	Telit / SC872-A

### Opinion on the Essential Requirements

Article 3.1a): Health and Safety	No remarks
Article 3.1b): Electromagnetic Compatibility	No remarks
Article 3.2: Effective Use of the Radio Spectrum	No remarks

### CE-marking

Marking Example (Class 1) **CE 0700**

This certificate is issued in accordance with the Directive 1999/5/EC of the European Parliament and the Council on radio equipment and telecommunications terminal equipment and the mutual recognition of their conformity dated 9<sup>th</sup> March 1999 and is only valid in conjunction with the following annex (2 pages).  
This version of the certificate replaces the expertise 14-117245, which is hereby withdrawn.

Blomberg, 23 December 2014

Place, Date of Issue



Signed by Bernd Seick  
Notified Body



## 13.2. RoHS Certificate

The Telit SC872-A module is fully compliant with the EU RoHS Directives.



## 14. Glossary and Acronyms

### **AGPS: Assisted GPS**

AGPS provides ephemeris data to the receiver to allow faster cold start times than would otherwise be possible.

This extended ephemeris data could be either server-generated or locally-generated.

### **Almanac:**

A set of orbital parameters for all GPS satellites that allows calculation of approximate GPS satellite positions and velocities. The almanac is used by a receiver to determine satellite visibility and as an aid during acquisition of GPS satellite signals. The almanac is reduced-precision set of ephemeris data and is updated weekly by GPS Control. See

### **BeiDou (BDNS / formerly COMPASS)**

BeiDou Satellite Navigation System (BDS), also known as COMPASS or BeiDou-2, Global satellite navigation system used by China and Asia Pacific region

### **Cold Start:**

A cold start acquisition assumes that the receiver's position and time, along with ephemeris data, is unknown. Almanac information may be used to identify previously healthy satellites and their approximate position.

### **Cold Start Acquisition Sensitivity:**

The lowest signal level at which a GNSS receiver is able to reliably acquire satellite signals and calculate a navigation solution from a Cold Start. Cold start acquisition sensitivity is limited by the data decoding threshold of the satellite messages.

### **EGNOS: European Geostationary Navigation Overlay Service**

The system of geostationary satellites and ground stations developed in Europe to improve the position and time calculation performed by the GPS receiver. Also see WAAS.

### **Ephemeris (plural ephemerides):**

A set of satellite orbital parameters that is used by a GPS receiver to calculate precise GPS satellite positions and velocities. The ephemeris is used to determine the navigation solution and is updated frequently (normally every 2 hours) to maintain the accuracy of the position calculation.

### **ESD: Electro-Static Discharge**

Large, momentary, unwanted electrical currents that cause damage to electronic equipment.

### **Galileo:**

Global navigation satellite system (GNSS) currently being built by the European Union (EU) and European Space Agency (ESA), intended for civilian use.

### **GDOP: Geometric Dilution of Precision**

A factor used to describe the effect of satellite geometry on the accuracy of the time and position solution of a GNSS receiver. A lower the value of GDOP indicates a smaller error in the solution. Related factors include PDOP, HDOP, TDOP and VDOP.



**GLONASS: Global Navigation Satellite System**

[Satellite navigation](#) system operated by the [Russian Aerospace Defense Forces](#)

**GNSS: Global Navigation Satellite System**

Term used for a satellite navigation system with global coverage

**GPS: Global Positioning System**

The U.S. GNSS space-based radio positioning system that provides accurate position, velocity, and time data.

**Hot Start:**

A hot start results from a software reset after a period of continuous navigation, or a return from a short idle period (i.e. a few minutes) that was preceded by a period of continuous navigation. All of the critical data (position, velocity, time, and satellite ephemeris) is current and available in memory.

**LCC: Leadless Chip Carrier**

A module design without pins. In place of the pins are pads of bare gold-plated copper that are soldered to the printed circuit board.

**LNA: Low Noise Amplifier**

An electronic amplifier used for very weak signals.

**Local Ephemeris prediction data:**

AGPS prediction of extended ephemeris from broadcast data (downloaded from satellites), which is stored in memory. Useful for up to three days.

**MSD: Moisture sensitive device.**

**Navigation Sensitivity:** The lowest signal level at which a GNSS receiver is able to reliably maintain navigation after the satellite signals have been acquired.

**NMEA: National Marine Electronics Association**

**QZSS: Quasi-Zenith Satellite System**

Satellite Based Augmentation System for GPS which is receivable within Japan and Oceania

**RoHS: The Restriction of Hazardous Substances**

Directive on the restriction of the use of certain hazardous substances in electrical and electronic equipment, was adopted in February 2003 by the European Union.

**RTC: Real Time Clock**

An electronic device (chip) that maintains time continuously while powered up.

**SAW: Surface Acoustic Wave filter**

Electromechanical device used in radio frequency applications. SAW filters are useful at frequencies up to 3 GHz.



**SBAS: Satellite Based Augmentation System**

A system that uses a network of ground stations and geostationary satellites to provide differential corrections to GNSS receivers. Current examples are EGNOS, WAAS, and MSAS.

**Server-based Ephemeris prediction:**

A prediction of GPS extended ephemeris accomplished on a server and provided to the receiver over a network. The data is generally usable for up to 14 days.

**TCXO: Temperature-Compensated Crystal Oscillator**

**Tracking Sensitivity:**

The lowest signal level at which a GNSS receiver is able to maintain tracking of a satellite signal after acquisition is complete.

**TTFF: Time to First Fix**

The elapsed time required by a receiver to achieve a valid position solution from a specified starting condition. This value will vary with the operating state of the receiver, the length of time since the last position fix, the location of the last fix, and the specific receiver design. A standard reference level of -130 dBm is used.

**UART: Universal Asynchronous Receiver/Transmitter**

An integrated circuit (or part thereof) which provides a serial communication port for a computer or peripheral device.

**WAAS: Wide Area Augmentation System**

The system of satellites and ground stations developed by the FAA (Federal Aviation Administration) that provides DGPS corrections. WAAS satellite coverage is usable in North America. Also see EGNOS.

**Warm Start:**

A warm start typically results after a period of continuous navigation is followed by an extended period of continuous RTC operation with an accurate last known position available in memory. In this state, position and time data are present and valid but ephemeris data validity has expired.





## 15. Safety Recommendations

### READ CAREFULLY

Be sure the use of this product is allowed in the country and in the environment required. The use of this product may be dangerous and has to be avoided in the following areas:

- Where it can interfere with other electronic devices in environments such as hospitals, airports, aircrafts, etc.
- Where there is risk of explosion such as gasoline stations, oil refineries, etc. It is responsibility of the user to enforce the country regulation and the specific environment regulation.

Do not disassemble the product; any mark of tampering will compromise the warranty validity. We recommend following the instructions of the hardware user guides for a correct wiring of the product. The product has to be supplied with a stabilized voltage source and the wiring has to be conforming to the security and fire prevention regulations. The product has to be handled with care, avoiding any contact with the pins because electrostatic discharges may damage the product itself.

The system integrator is responsible of the functioning of the final product; therefore, care has to be taken to the external components of the module, as well as of any project or installation issue. Should there be any doubt, please refer to the technical documentation and the regulations in force. Every module has to be equipped with a proper antenna with specific characteristics. The antenna has to be installed with care in order to avoid any interference with other electronic devices.

The European Community provides some Directives for the electronic equipment introduced on the market. All the relevant information's are available on the European Community website:

<http://ec.europa.eu/enterprise/sectors/rte/documents/>

The text of the Directive 99/05 regarding telecommunication equipment is available, while the applicable Directives (Low Voltage and EMC) are available at:

<http://ec.europa.eu/enterprise/sectors/electrical/>



**Caution – Risk of explosion if Battery is replaced by an incorrect type.  
Dispose of used batteries according to the instructions**





## 16. Document History

Revision	Date	Changes
0	2015-04-29	First issue
1	2015-06-15	Updated voltage range §8.2

