



SE150A4

EVB User Guide

1VV0301694 Rev. 1 – 2021-05-17



APPLICABILITY TABLE

PART NUMBER
SE150A4 SMART EVB MAINBOARD (3990150671)
SE150A4-NA INTERFACE FOR SMART EVB
SE150A4-EU INTERFACE FOR SMART EVB



Contents

APPLICABILITY TABLE	2
CONTENTS	3
1. INTRODUCTION	6
1.1. Scope	6
1.2. Audience	6
1.3. Contact Information, Support	6
1.4. Text	6
1.5. Related Documents	7
2. GENERAL PRODUCT DESCRIPTION	8
2.1. Overview	8
2.2. Content of the Kit	8
3. FUNCTIONAL DESCRIPTION	12
3.1. Block Diagram	12
3.2. Main Connectors and Devices Layout	13
3.3. Switch and Jumpers Settings	14
4. POWER SUPPLY	16
4.1. Power Supply Source Selection	16
4.2. Power consumption monitoring	19
4.3. Battery Charging	19
5. PERIPHERALS	20
5.1. Display (LCM)	20
5.2. Touch Panel	21
5.3. Main USB	21
5.4. UART	22
5.5. USIM Interfaces	23
5.6. SD CARD	24
5.7. Control buttons	25
5.8. POWER Key	25

5.8.1.	RESET Key	25
5.8.2.	VOLUME Keys	26
5.8.3.	Keys Combinations	26
5.9.	Sensors	27
5.9.1.	Accelerometer	27
5.9.2.	Proximity	27
5.10.	Audio	28
5.10.1.	Digital Microphone	29
5.10.2.	De-Noising Microphone	29
5.10.3.	Handset	29
5.10.4.	Headset	30
5.10.5.	Speaker	31
5.10.6.	Vibrator	32
5.11.	ADC	32
5.12.	VCOIN	32
5.13.	GPIO	33
5.14.	Board to Board Connectors	33
6.	SE150A4 SMART MODULE INTERFACE	35
6.1.	Description	35
6.2.	Main Connectors and Devices Layout	36
6.3.	Camera	36
6.3.1.	Front Camera	36
6.3.2.	Rear Camera	37
6.4.	RF Connectors	37
6.5.	USB BOOT	38
7.	PRODUCT AND SAFETY INFORMATION	41
7.1.	Copyrights and Other Notices	41
7.1.1.	Copyrights	41
7.1.2.	Computer Software Copyrights	41
7.2.	Usage and Disclosure Restrictions	42
7.2.1.	License Agreements	42
7.2.2.	Copyrighted Materials	42
7.2.3.	High Risk Materials	42



7.2.4.	Trademarks	42
7.2.5.	Third Party Rights	43
7.2.6.	Waiver of Liability	43
7.3.	Safety Recommendations	43
8.	ACRONYMS	45
9.	DOCUMENT HISTORY	46

1. INTRODUCTION

1.1. Scope

This document introduces the EVB for the SE150A4 Smart Module and describes all its characteristics and functionalities. All the features and solutions detailed in this document are applicable to all SE150A4 Smart Module variants, where SE150A4 Smart Module refers to the variants listed in the applicability table.

1.2. Audience

The Telit SE150A4 Smart Module EVB is a development board designed for engineers, programmers and developers who are looking to:

- Develop and test applications based on current and future Telit Smart Module families via Android
- Debug and/or Improve Android applications based on Telit Smart Modules

1.3. Contact Information, Support

For general contact, technical support services, technical questions and report documentation errors contact Telit Technical Support at:

- TS-EMEA@telit.com
- TS-AMERICAS@telit.com
- TS-APAC@telit.com
- TS-SRD@telit.com

Alternatively, use: <http://www.telit.com/support>

For detailed information about where you can buy the Telit modules or for recommendations on accessories and components visit <http://www.telit.com>

Our aim is to make this guide as helpful as possible. Keep us informed of your comments and suggestions for improvements.

Telit appreciates feedback from the users of our information.

1.4. Text



Danger: This information MUST be followed or catastrophic equipment failure or personal injury may occur.



Warning: Alerts the user on important steps about the module integration.



Note/Tip: Provides advice and suggestions that may be useful when integrating the module.



Electro-static Discharge: Notifies the user to take proper grounding precautions before handling the product.

Table 1: Symbol Conventions

All dates are in ISO 8601 format, that is. YYYY-MM-DD.

1.5. Related Documents

Module Name	Description
1V0301698	SE150A4 Smart Module Hardware User Guide
1V0301695	SE150A4 Smart Module SDK User Guide

2. GENERAL PRODUCT DESCRIPTION

2.1. Overview

The Telit SE150A4 Smart Module is a multi-mode and multi-band wireless smart module, which is based on Qualcomm QCM2150 platform. It includes baseband, memory, RF front end and required circuitry to support rich multimedia features, global location-based service, wireless connectivity, and air interface standards including GSM, WCDMA, and LTE.

With higher integration to reduce PCB surface area, time-to-market, and BOM costs, Telit SE150A4 Smart Module will help drive wireless products adoption in industries around the world.

SE150A4 Smart Module is based on Android operating system and it helps customers to develop embedded devices without host MCU or processors.

The SE150A4 Smart Module EVB is a system permitting the customer to evaluate and test the module's functionalities with a first set of peripherals such a display, camera and sensors.

The SE150A4 Smart Module EVB is integrated with the following items:

- LCM
- Proximity Sensor and Ambient Light sensor
- Accelerometer (G-Sensor)
- Two Camera (Front / Rear)
- Analog / Digital audio
- Two SIM card holders
- One USB interface for the main Module's port
- Two UART ports available on an USB hub adapter (for debug purposes)
- 4 buttons (Power Key, Reset, VOL+ and VOL-)
- T-FLASH card interface
- Battery charger

2.2. Kit Content

The Telit SE150A4 Smart Module EVB kit consists of the following Items:

Item	Quantity
Telit SE150A4 Smart Module EVB Mainboard	1
Power Supply adapter	1
SMA female to UFL cable (length: 120mm)	3
Multi Band RF antenna (with SMA male connector)	3

The EVB Mainboard is shown in the following image:

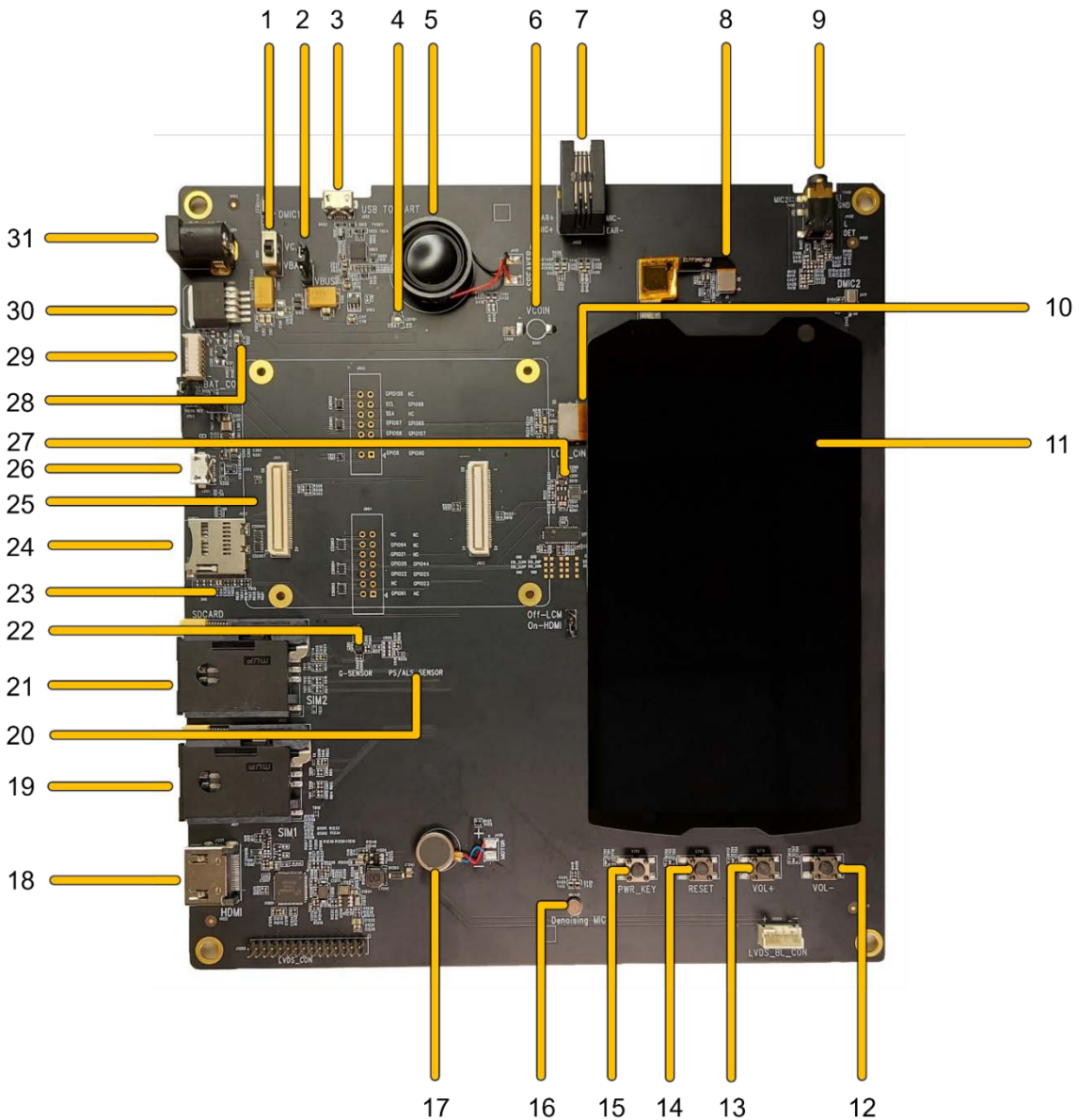

1	Power Switch
2	VBUS
3	UART
4	Power-On indicator
5	Speaker
6	VCOIN
7	Earpiece and MIC
8	TP Interface
9	Headphone Jack
10	LCM Interface
11	LCM
12	Volume -
13	Volume +

14	Reset button
15	Power button
16	Denoising MIC
17	Vibrator
18	HDMI Port
19	SIM Card slot 1
20	PS/ALS Sensor
21	SIM Card slot 2
22	G-Sensor
23	SD Card test points
24	SD Card slot
25	TE Board connector
26	Micro USB port

27	Backlight driver
28	Q102
29	Battery connector
30	LDO
31	DC Jack

The EVB can host one SE150A4 TE board, which is shown below:



The picture below shows how to install the SE150A4 TE board on to the EVB:

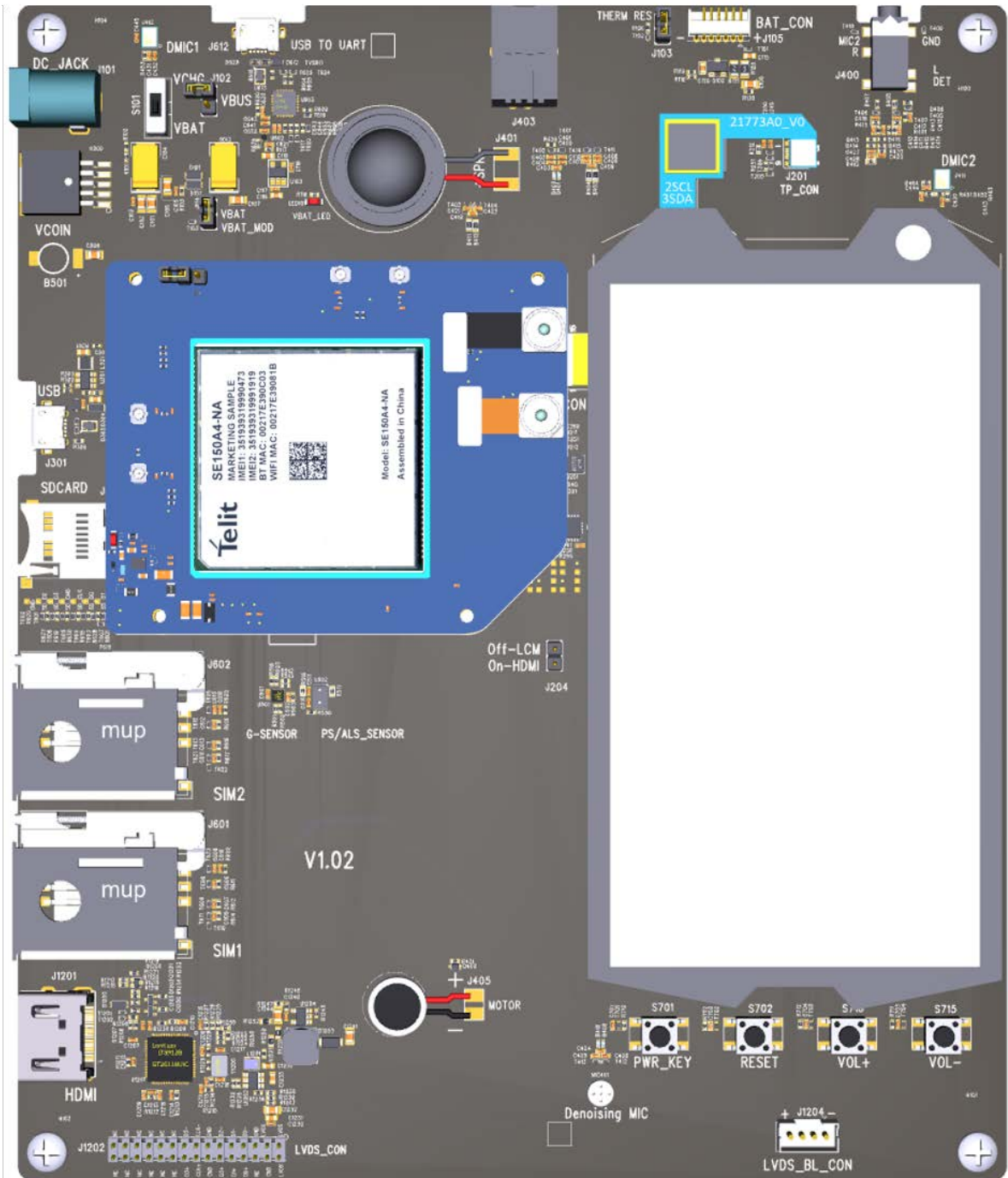

3. FUNCTIONAL DESCRIPTION

3.1. Block Diagram

The SE150A4 Smart Module EVB is a motherboard allows you to connect and use the Telit SE150A4 Smart Module's Interface. It can be split into several functional blocks depending on the implemented function; the following image is detailn the block diagram:

The following is the architecture block diagram:

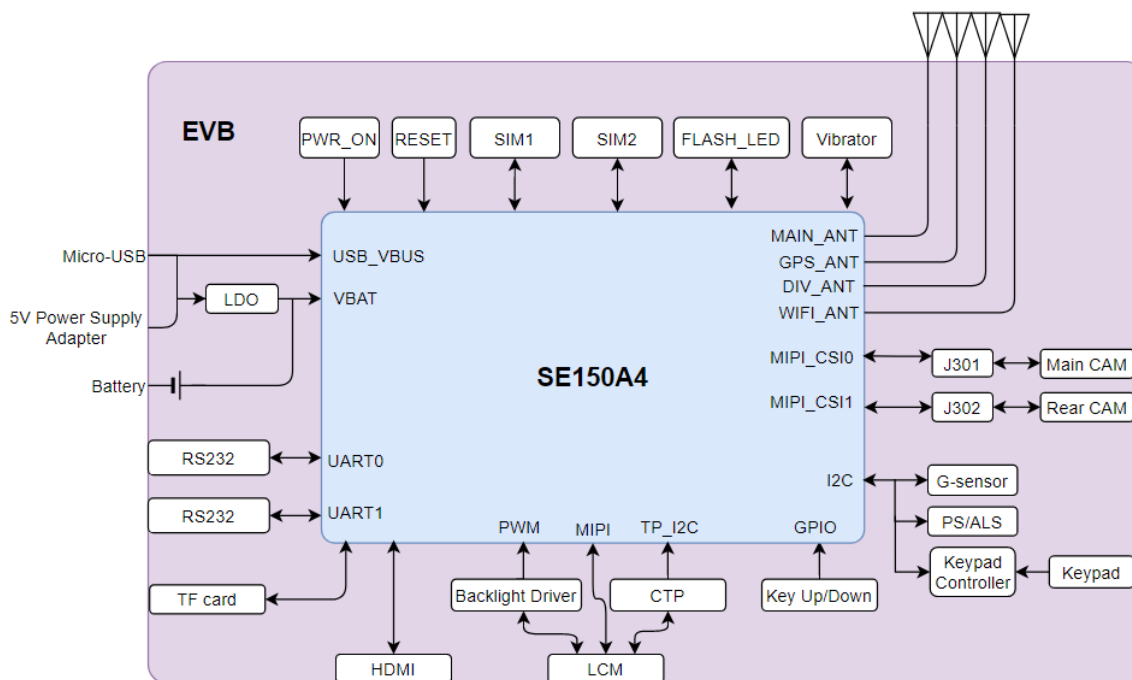

3.2. Main Connectors and Devices Layout

The following is the main connectors position and EVB devices diagram:

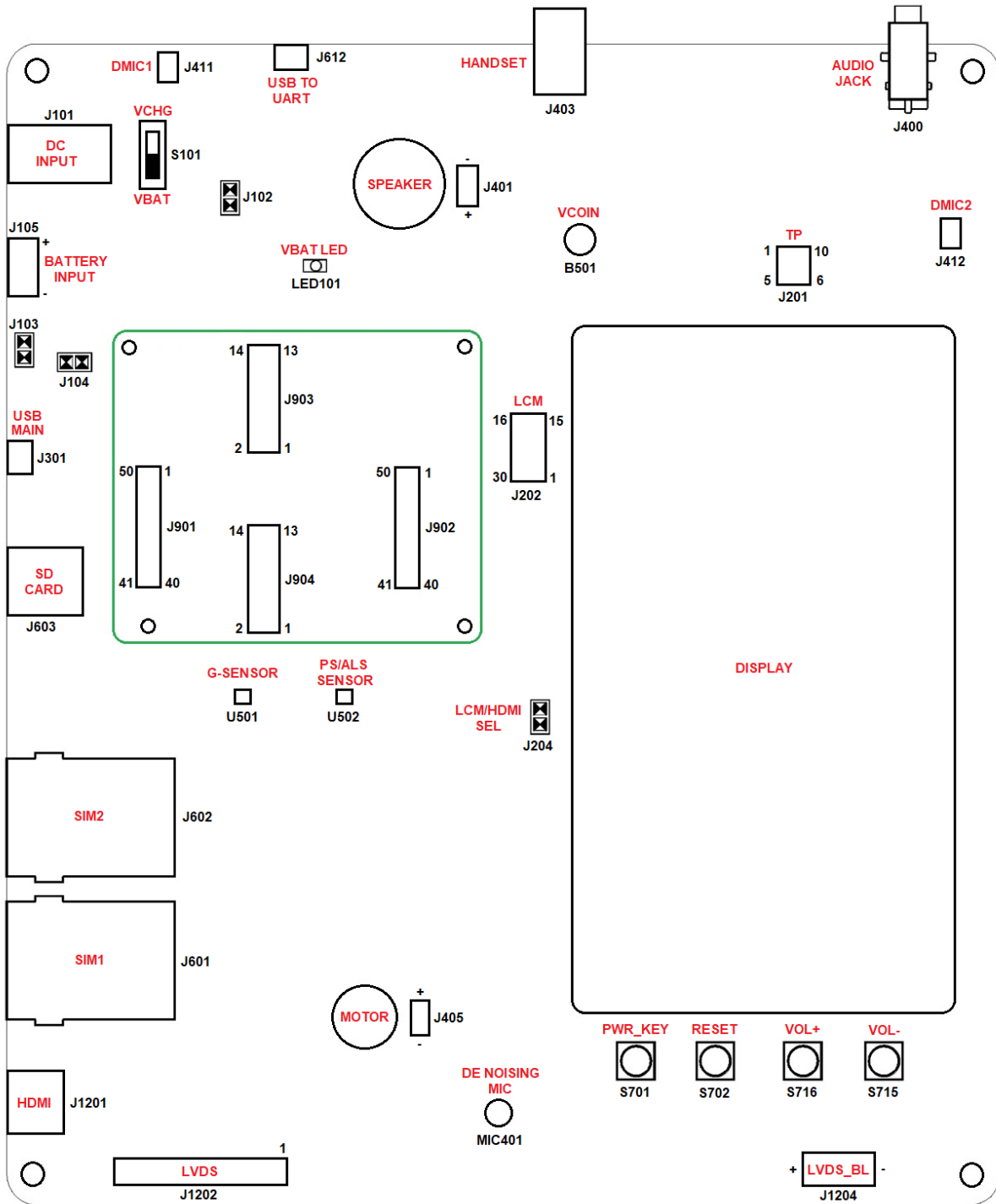

3.3. Switch and Jumpers Settings

The following is the EVB default switch and jumper position diagram:

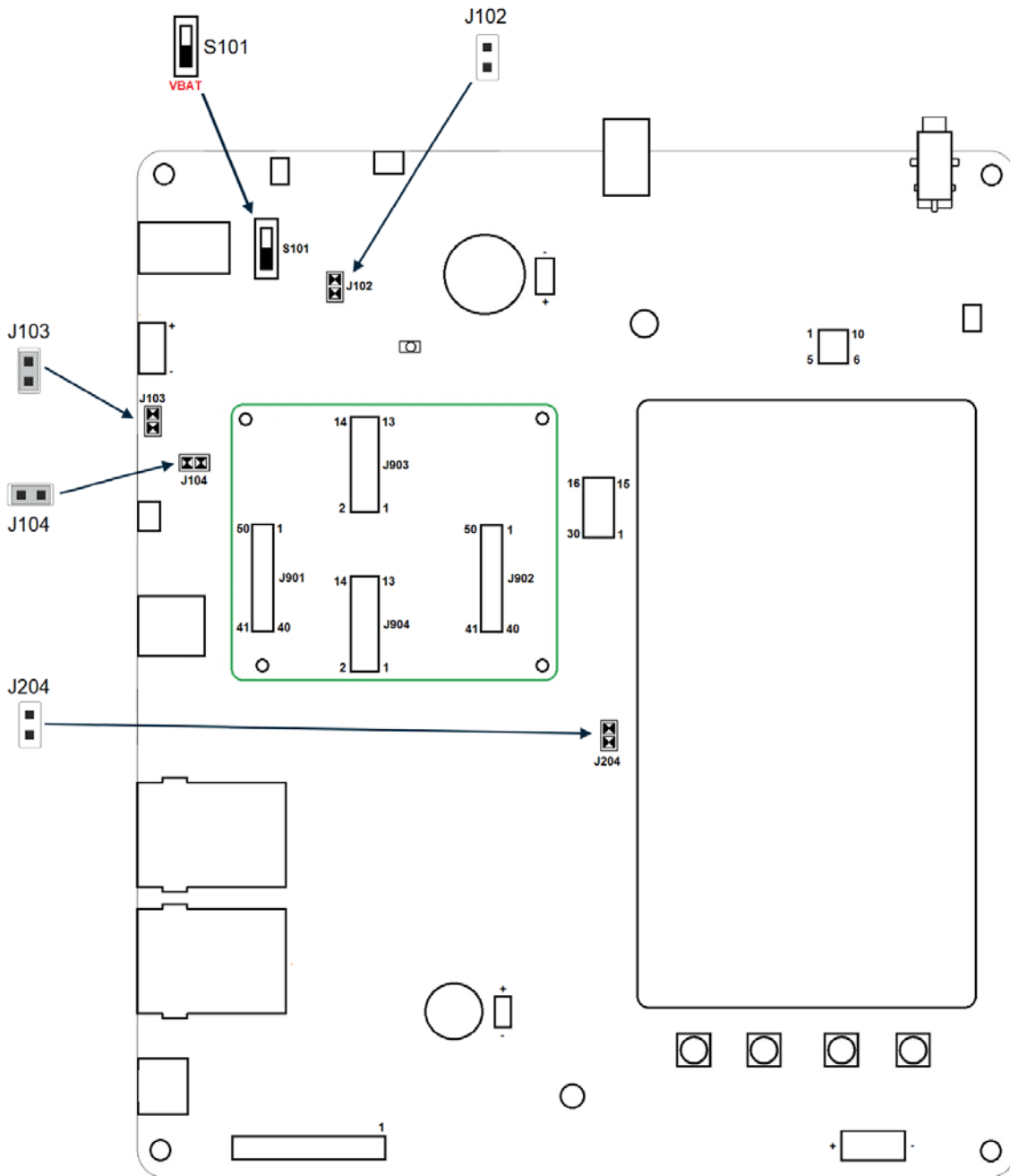

The Jumpers and Switches functional description is described in the following table:

Jumper / Switch	Default Setting	Function	Statuses
J102	Open	In series to 5V DC when connected to VUSB via S101. Can be used to perform Power consumption measurements.	OPEN when S101 is on VBAT position CLOSED when S101 is on VCHG position
J103	Closed	The jumper when closed is adding a Pull down resistor of 47Kohm to the BAT_THERM line.	CLOSED when supplying EVB with the DC INPUT connector OPEN when supplying the EVB with the Battery (using connector J105)
J104	Closed	In series to VBAT provided to the module. Can be used to perform Power consumption measurements.	CLOSED in most of the uses OPEN when required to unconnect Module's VBAT
J204	Open	Permits to select which display bus to use (LCM display or HDMI/LVDS)	OPEN if LCM Display is used CLOSED if HDMI/LVDS port is used
S101	VBAT	Permits to select if 5V DC supply from DC INPUT is connected to the VUSB line (Module's main USB port) or to the main DCDC adapter for VBATT	VBAT if 5VDC is applied to internal DCDC for VBAT CHR if HDMI/LVDS port is used

4. POWER SUPPLY

4.1. Power Supply Source Selection

The EVB can be powered from a power adapter or a battery depending on the use case.

The following is the circuit diagram:

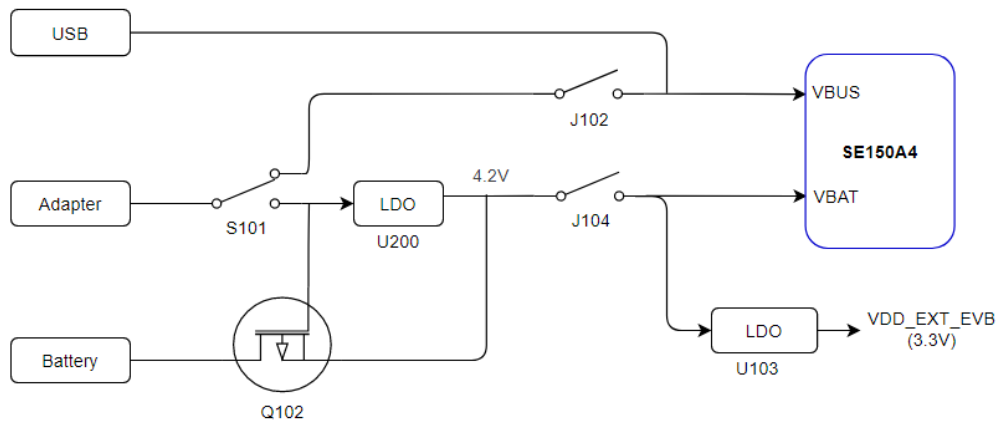

If the 5V power adapter is connected to EVB, switch S101 must be set to VBAT position, and jumpers J102 and J104 need to be closed to power up the EVB.

If the battery (3.5V ~ 4.4V) is connected to EVB, jumper J104 needs to be closed, to power up the EVB.

MOSFET Q102 prevents the adapter and the battery from being supplying the power to EVB at the same time.

There is a Power-on indicator LED101 on EVB. This LED glows in red color when the DC power supply or battery power supply is normal.

The following is the circuit diagram:

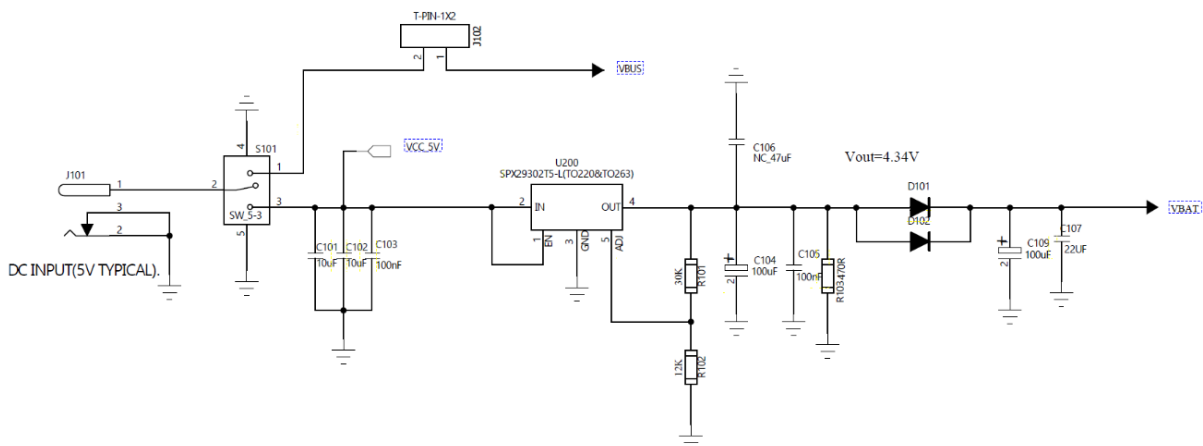

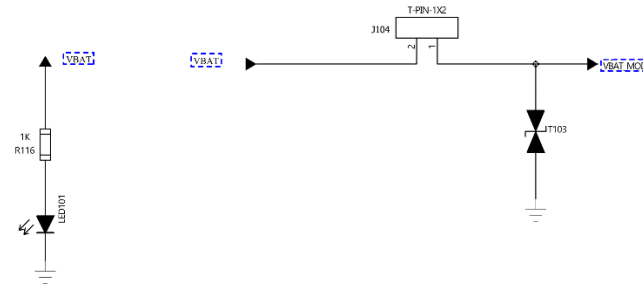

The following is the circuit diagram:

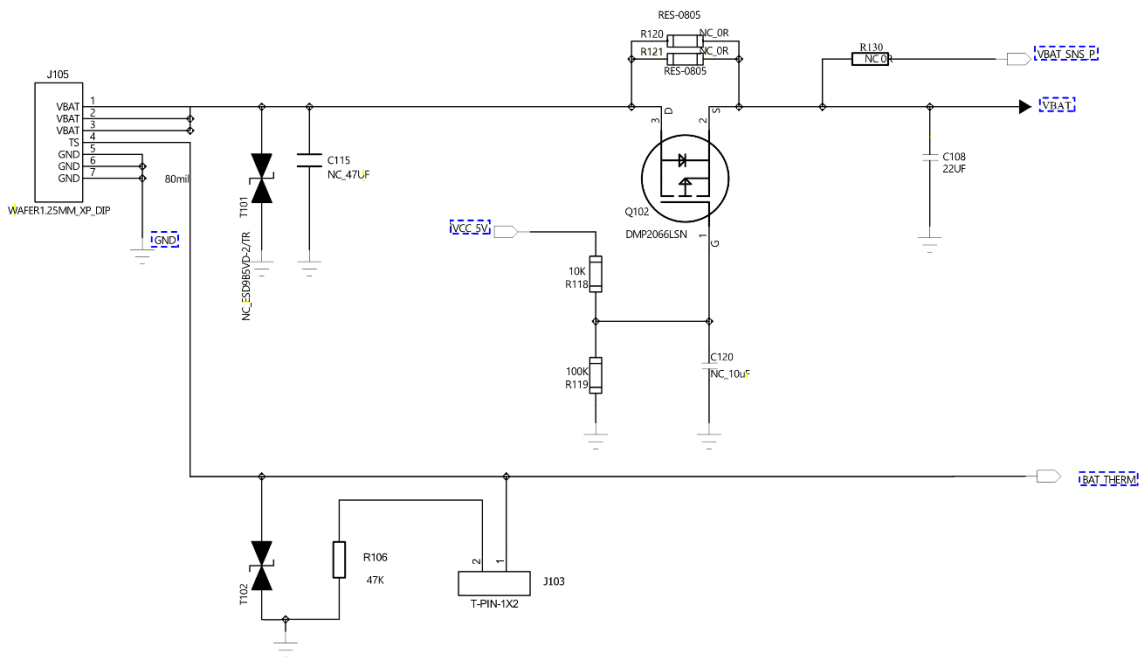

The EVB internally supplies its peripherals with some LDO outputs (1.8V, 2.85 and VSIM) from the SE150A4 Smart Module and with a 3.3V LDO (VDD_EXT_EVB).

The 3.3V LDO schematic:

The following is the circuit diagram:

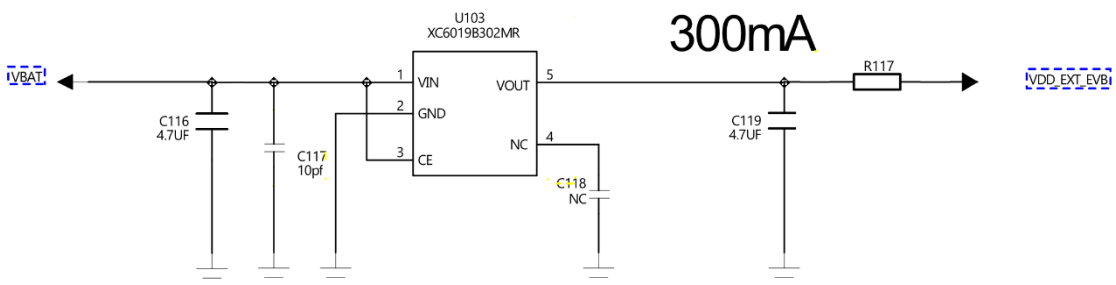

The following table is detailing the involved LDOs:

Peripheral	Connector	Description
LCM	J201	LDO6_1P8(125pin), LDO17_2P85(129pin)
Backlight	U201	VBAT
Capacitive Touch Panel	J202	LDO17_2P85(129pin), LDO6_1P8(125pin)
Flashlight	U301 LED301	VBAT
Camera	J301 J302	LDO6_1P8(125pin) for Camera DVDD LDO17_2P85(129pin) for Camera AVDD
G-sensor	U501	LDO6_1P8(125pin)
ALS/PS Sensor	U701	VBAT, LDO17_2P85(129pin), LDO6_1P8(125pin)
Vibrator	J402	VIB_DRV_N(28pin)
TF Card	J603	LDO11_SDC (38pin)
SIM Card	J601 J602	VREG_L14_UIM1(26pin), VREG_L15_UIM2(21pin)
LED	D101	VBAT

The following is the power distribution diagram:

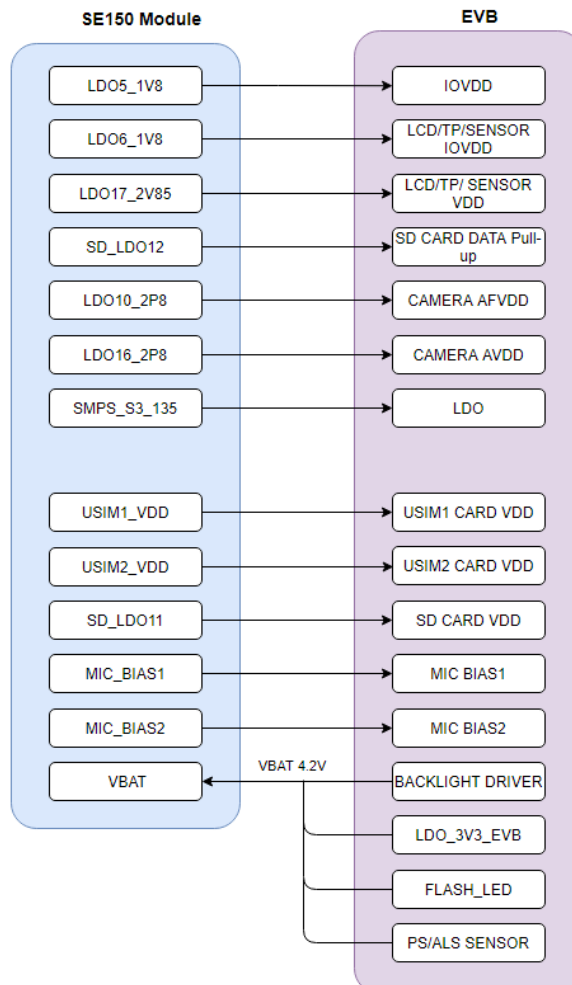

4.2. Power consumption monitoring

To facilitate module current consumption measurements two test points (VBAT and GND) are provided on the SE150A4 Smart Module-TE board. To supply power to VBAT and GND test points remove the jumper J104 from the EVB.



Note/Tip: To measure the SE150A4 Smart Module current consumption, EVB needs to be powered separately, so that the LCM will work normally..

4.3. Battery Charging

To charge the battery from a DC adapter or a micro USB port, the EVB includes a battery connector J103. Battery connection is optional to operate the EVB. Battery could be useful for field trials, drive tests, and demos to avoid unexpected power cuts.

The battery is charged if the EVB is powered by the adapter. Note that jumpers J102 and J104 need to be closed and S101 is moved to VBAT position. If battery charging function is not required, remove jumper on J102.

If the EVB is powered by adapter, it is necessary to pull down BAT_THERM (module pin VBATT_THERM, Pin 134) to GND with a 47K resistor, otherwise charging and power supply will be abnormal.

When the battery is used to power on the EVB, the value of R106 must be equal to the internal NTC resistance of the battery at normal temperature, hence $R106 = 47K\Omega$.

5. PERIPHERALS

5.1. Display (LCM)

The most important peripheral for a Smart Module is the Display (or also called LCM: “Liquid Crystal Monitor”) that includes additional items such as the Capacitive Touch Panel (CTP) and a backlight driver. Details of the LCM used with this EVB are listed below:

Item	Description
Display Type	Amorphous silicon TFT (a-Si TFT)
Display Colors:	16.7M
Resolution:	720*1280
Pixel Pitch:	0.08625(H)*0.08625(V)
LCM Dricver IC:	ILI9881D
Display Mode:	Transmissive /Normally Black
Luminance:	430cd/m2(typ)
Contrast:	900:1
LCM Interface Type:	MIPI DSI video mode
LCM Pin Numbers:	30
Pin Pitch:	0.4Pitch
Inoput Voltage:	VDD:2.8 or 3.3V,I0VCC:1.8V or VDD
Backlight Type and Color:	LED backlight /white
Backlight	12 LED, 2 groups in parallel, 6 LEDs in series in each group,Vf=19.2V, If=40mA

The LCM is connected to the EVB through the J202 connector.

The following is the circuit diagram:

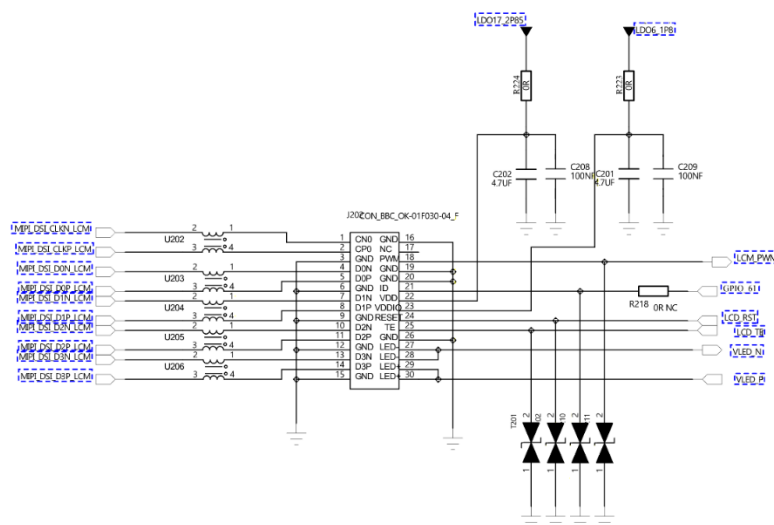

The following is the backlight circuit diagram:

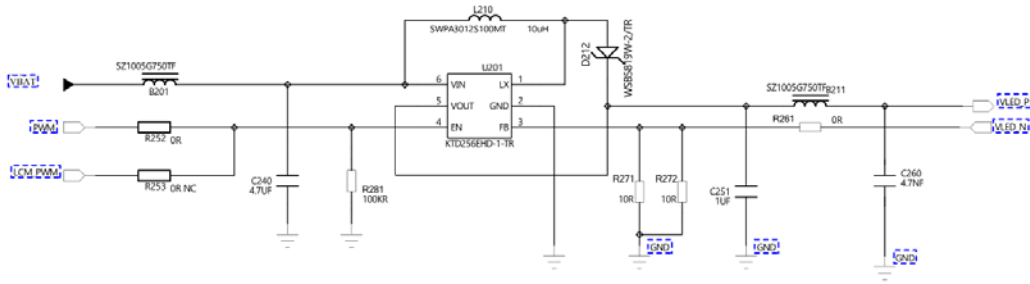

5.2. Touch Panel

The display is integrated with a Capacitive Touch Panel (CTP) driver GT5688.

This part is connected to the EVB through the J201 connector.

The following is the circuit diagram:

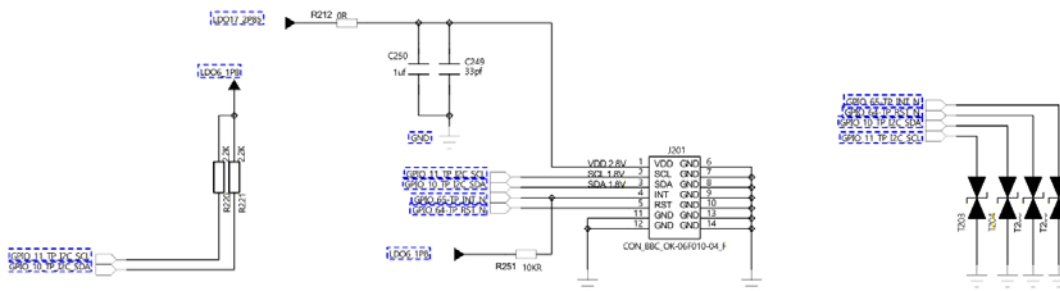

5.3. Main USB

To download firmware, debug, and trace the module includes a USB port to connect the Modem

The SE150A4 Smart Module USB port is connected to Micro USB port on EVB available on connector J301. Battery can also be charged from this port. It supports BC1.2 charging standard, maximum charging current can reach 1.44A.

The following is the circuit diagram:

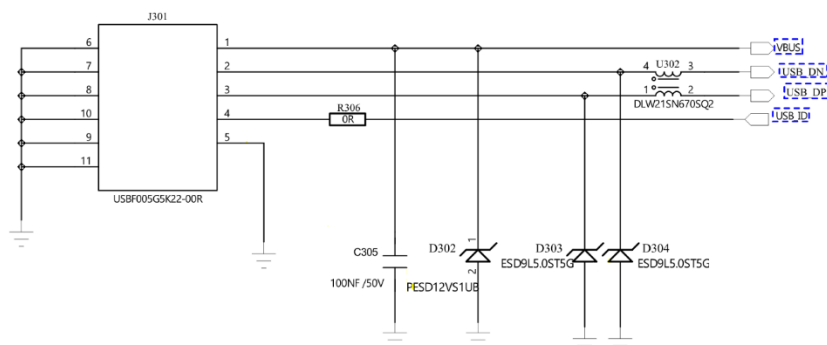

The following is the 5V boost circuit:

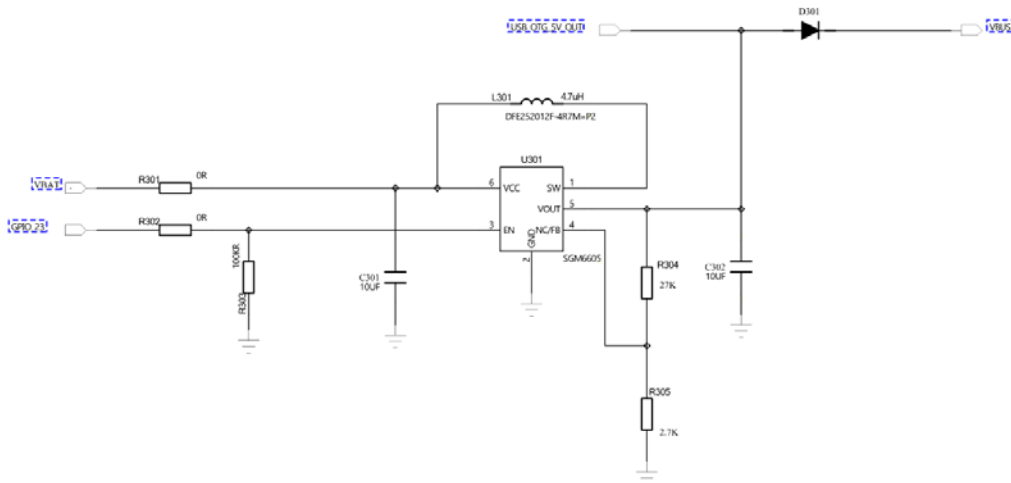

5.4. UART

The module has two UART ports. The UART1 port is for flow control (CTS and RTS). The UART2 port is not for flow control for debug or data communication. The two UART ports are connected to UART to USB converter chip CP2105. When the user connects USB cable to J612, two COM ports can be seen in Device manager.

The following is the circuit diagram:

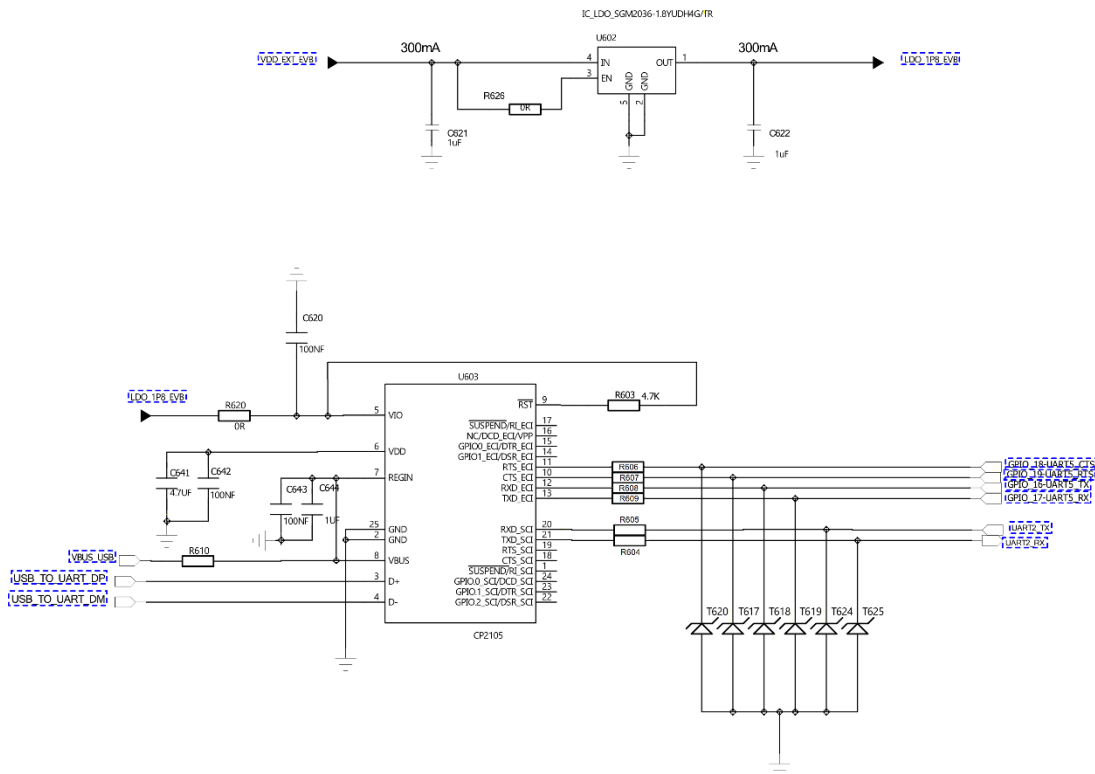

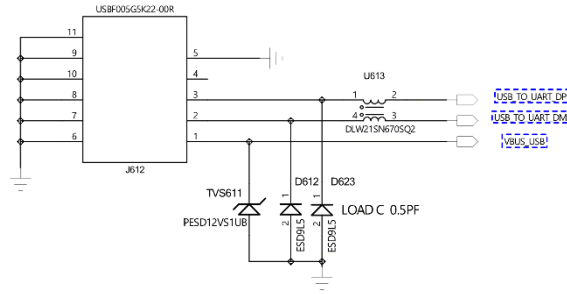

5.5. USIM Interfaces

The EVB has two SIM slots. Both slots support SIM presence pin usable for Hot Swap function.

USIM1 is available on J601, USIM2 on J602 card slot.

The following is the circuit diagram:

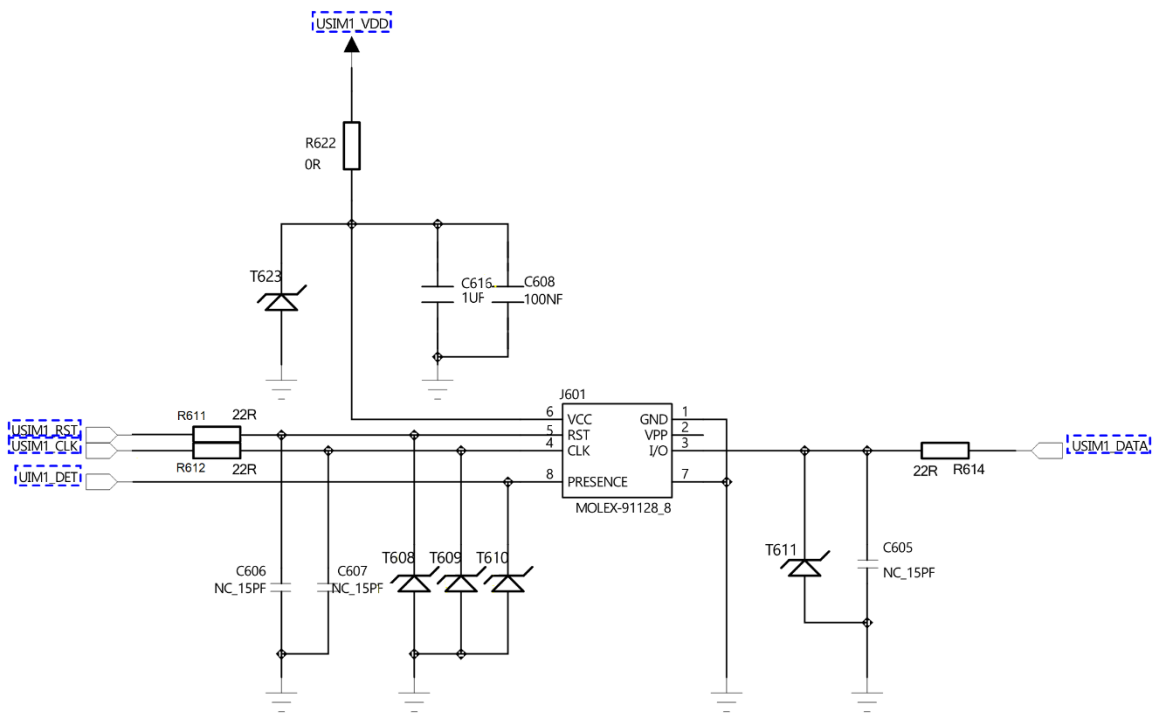

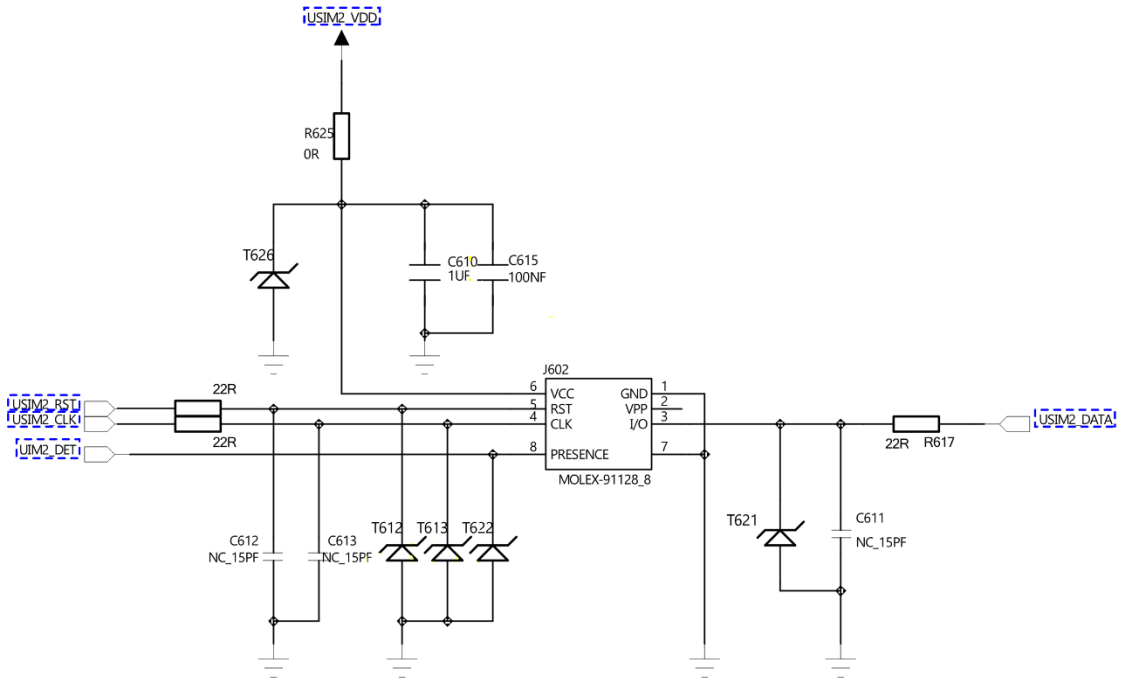

5.6. SD CARD

The SE150A4 Smart Module EVB includes a Mini SD Card slot (J603). It supports Hot Swap function.

The following is the circuit diagram:

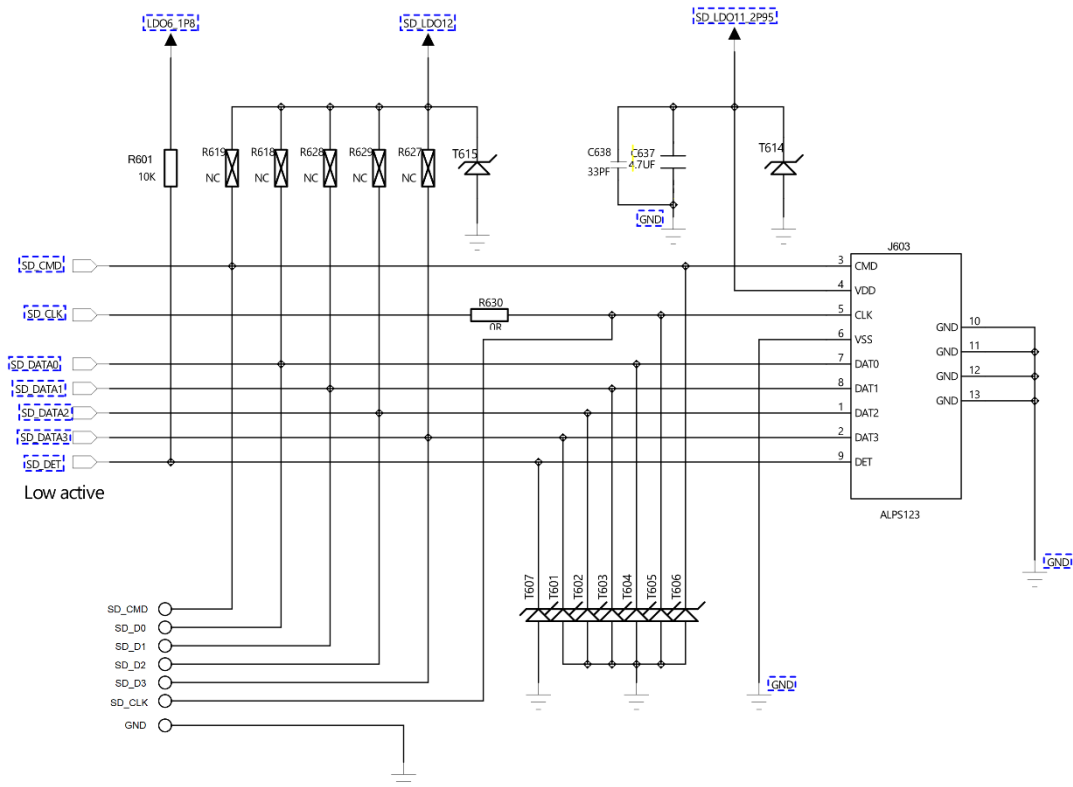

5.7. Control buttons

The SE150A4 Smart Module EVB has four buttons. These buttons functions are detailed in the below sub sections.

5.8. POWER Key

The Power Key is used to power on and off the SE150A4 Smart Module.

To power on the SE150A4 Smart Module:

1. Connect the power adapter
2. Switch on the power supply.
3. Press and hold the POWER Key till the Telit Logo is displayed.

For more information, see the SE150A4 Smart Module Hardware Design guide.

The following is the circuit diagram:

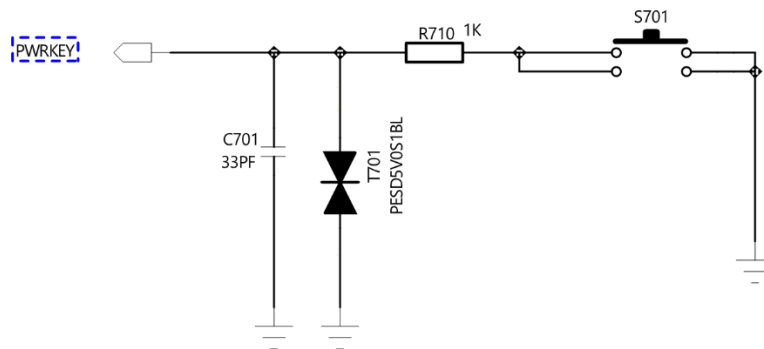

5.8.1. RESET Key

Used to run an unconditional restart of the SE150A4 Smart Module. Please refer the HW Design guide of SE150A4 Smart Module for the detailed timings.

The following is the circuit diagram:

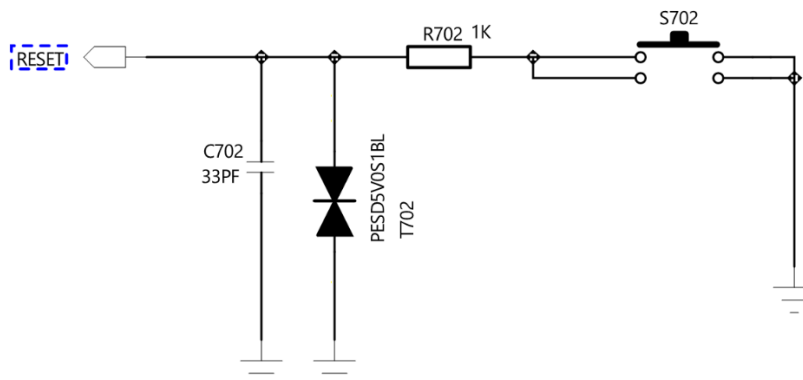

5.8.2. VOLUME Keys

Used to control the Audio Volume of the SE150A4 Smart Module.

The following is the volume up circuit diagram:

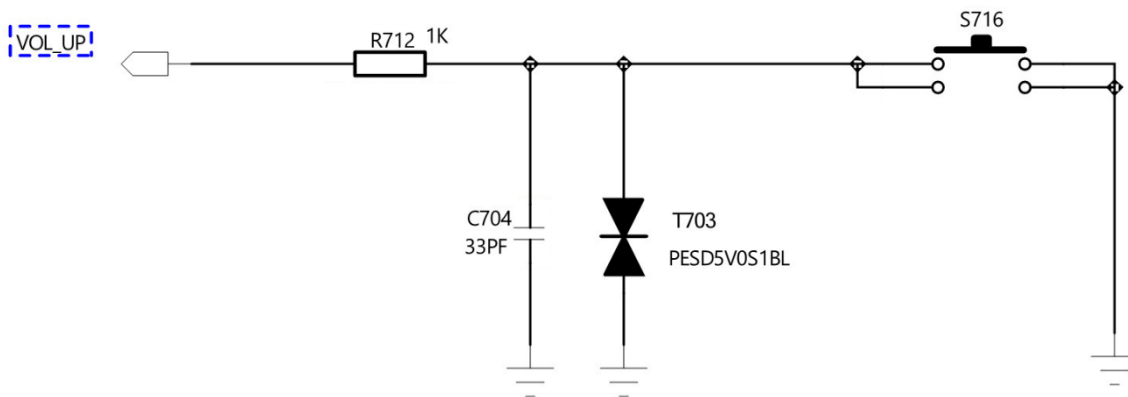

The following is the volume down circuit diagram:

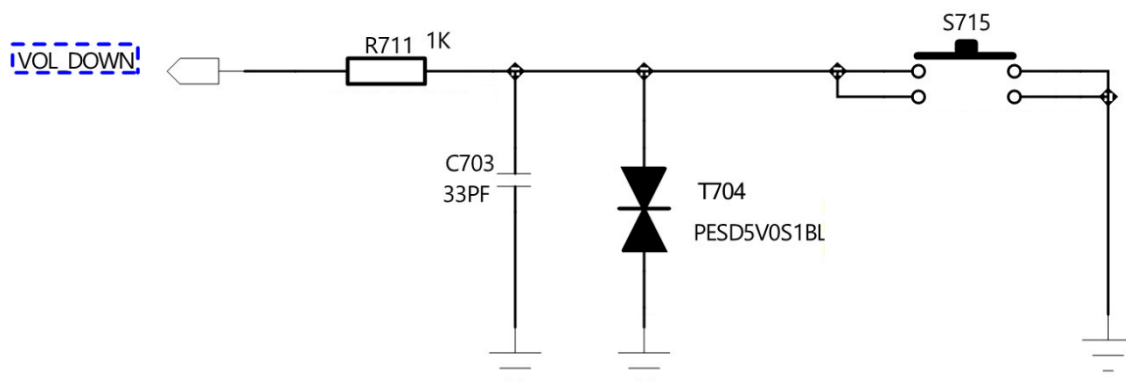

5.8.3. Key Combinations

The system also supports additional functions when pushing a combination of keys.

Pressing PWRKEY together with VOL + / VOL- allows to set the SE150A4 Smart Module in USB Force boot or Engineering mode.

The following table shows the Key combination functions:

	PWRKEY	VOL+	VOL-	Description
Key combination before Power Up	Y	Y	Y	Enter forced download mode
	Y	N	Y	Enter engineering mode

To boot in normal mode, connect the power supply to EVB, press the power button until the screen displays; then release the button.

5.9. Sensors

The SE150A4 Smart Module EVB has two sensors (Accelerometer and Proximity)

5.9.1. Accelerometer

Tri-axial low-g acceleration sensor from Bosch (BMA421) is used in the EVB.

The table below has details of the sensor:

Item	Value
Digital resolution	12 bit
Resolution (in $\pm 2g$ range)	0.98 mg
Measurement ranges (programmable)	$\pm 2 g$, $\pm 4 g$, $\pm 8 g$, $\pm 16 g$
Zero-g offset (typ., over life-time)	$\pm 100 mg$
Noise density (typ.)	$300 \mu g/vHz$
Bandwidths (programmable)	1600 Hz ... 1.5 Hz
Supply voltage (VDD)	1.62 ... 3.6 V
I/O supply voltage (VDDIO)	1.2 ... 3.6 V
FIFO data buffer	1 kB
Control	I2C
I2C Address	0x18

Additional details on the component could be found in the component's datasheet (ref. to supplier website).

The following is the BMA421 sensor circuit:

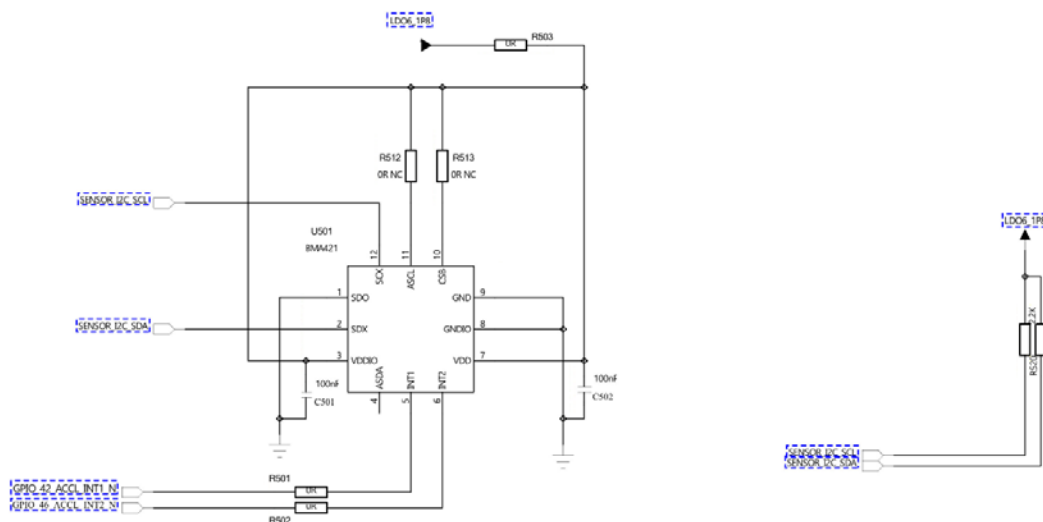

5.9.2. Proximity

The Proximity sensor is used to detect approaching objects. The EVB has Proximity (PS) and Ambient Light (ALS) sensor from Sensortek STK3311-X.

The table below has the details of the sensor:

Item	Value
PS Digital resolution	16 bit
ALS Digital resolution	16 bit
Control	I2C
I2C Address	0x48

Additional details on the component could be found in the component’s datasheet (ref. to supplier website).

The following is the STK3311-X sensor circuit:

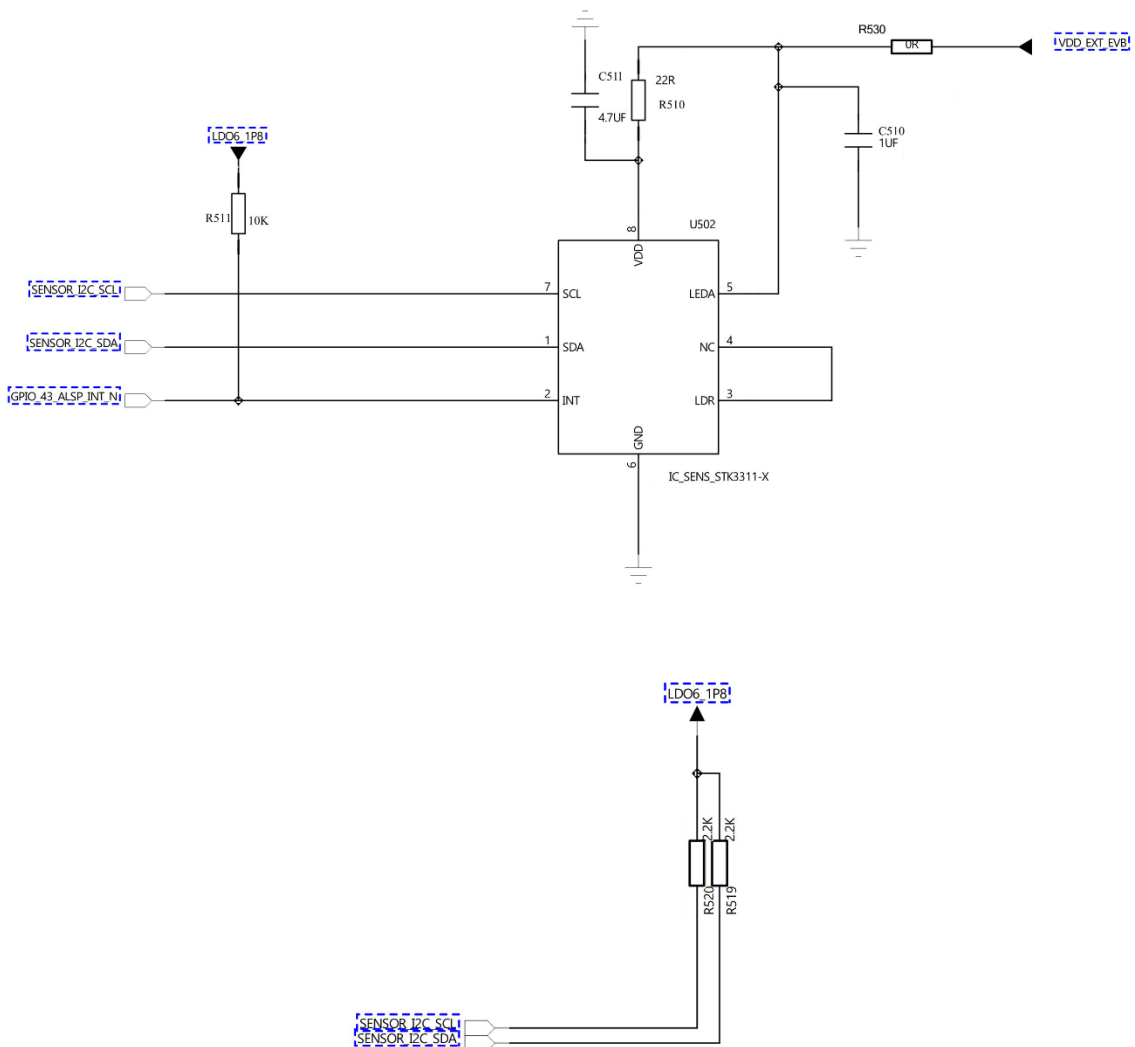

5.10. Audio

The SE150A4 Smart Module EVB has the necessary circuit for all the Audio Interfaces.

5.10.1. Digital Microphone

Two Digital microphones are available on the EVB.

The following is the circuit diagram:

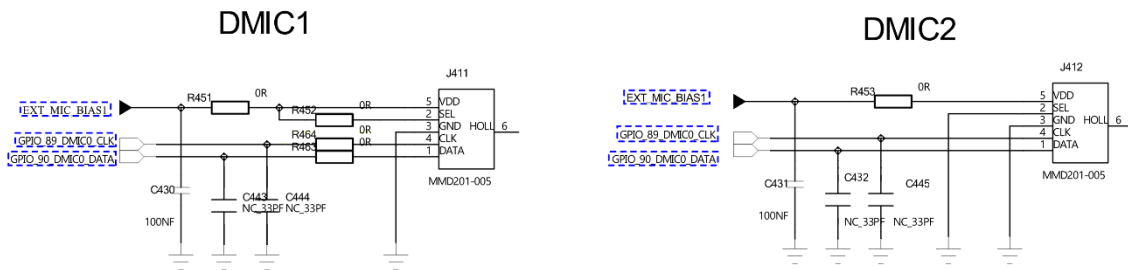

5.10.2. De-Noiseing Microphone

The Noise cancellation is performed using an additional microphone.

The following is the circuit diagram:

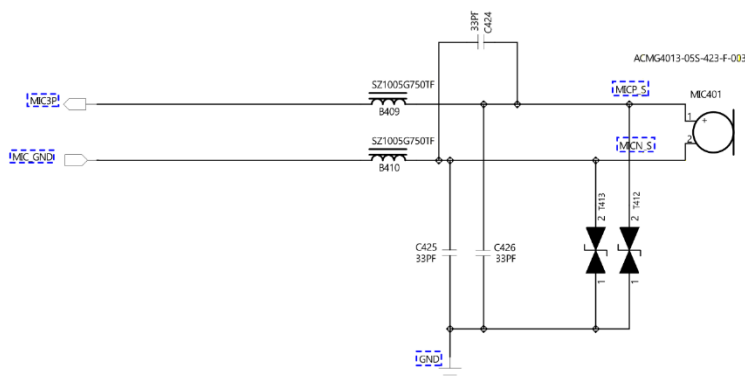

5.10.3. Handset

The Handset lines are available on an RJ11 connector (J403). The handset is often used for audio test.

The pinout is shown in the table below.:

Pin	Signal
1	MIC GND
2	EAR N
3	EAR P
4	MIC1 P

The following is the circuit diagram:

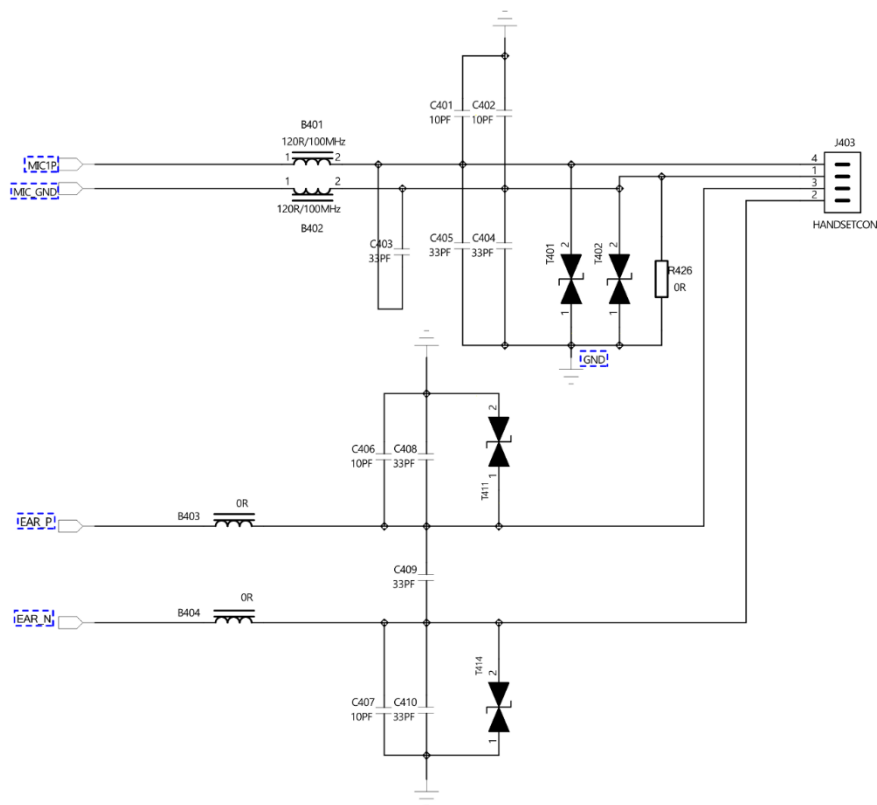

In the hands-free mode, the MIC used is the handset MIC, and the speaker is switched to the one present on EVB.

5.10.4. Headset

EVB has 3.5mm audio jack (J404), supports earphones having detection pins HS_DET and HPH_L (detection circuit). There is a pull-down resistor inside HPH_L, when headphones are not inserted, HS_DET and HPH_L are connected (status is LOW). When headphones are inserted, HS_DET and HPH_L are disconnected (status HIGH).

The following is the Headset jack pinout diagram:

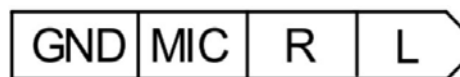

When the headset is inserted, there will be an interrupt to the SE150A4 Smart Module. Audio lines will be switched to headset mode..

The following is the circuit diagram:

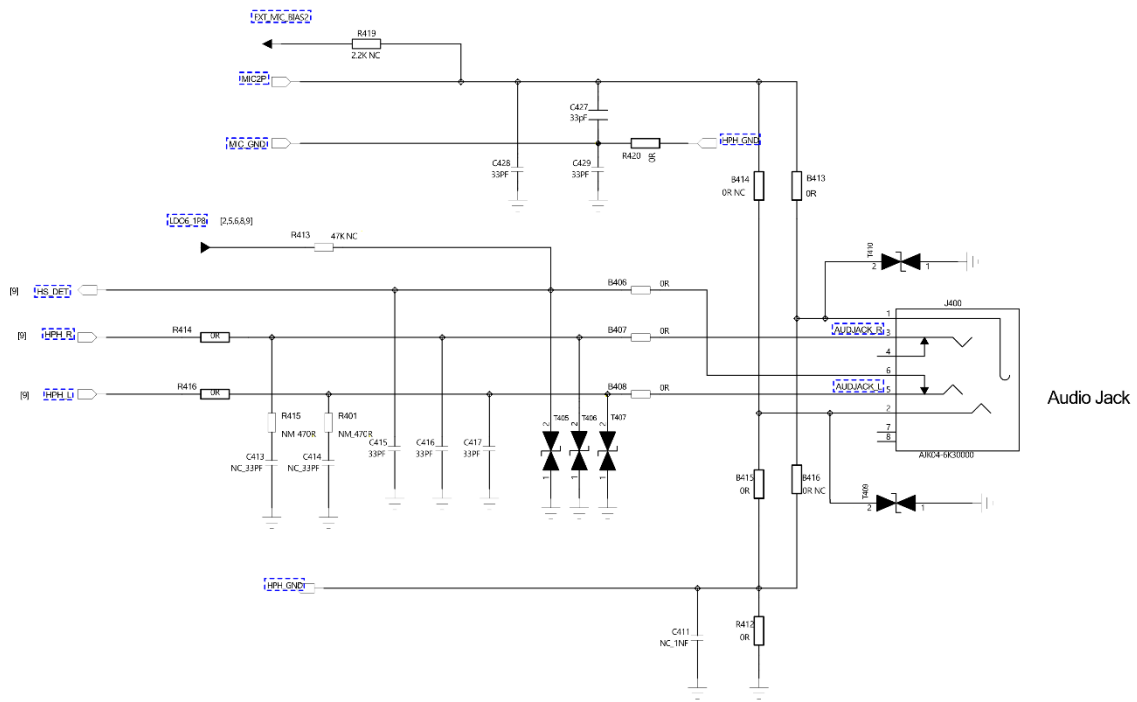

5.10.5. Speaker

The EVB includes a speaker for handsfree mode. It's circuit is shown below.

The following is the circuit diagram:

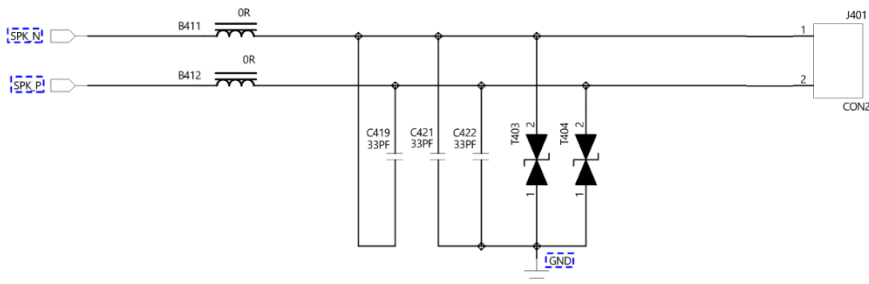

5.10.6. Vibrator

EVB has a Vibrator connected to J405

The following is the circuit diagram:

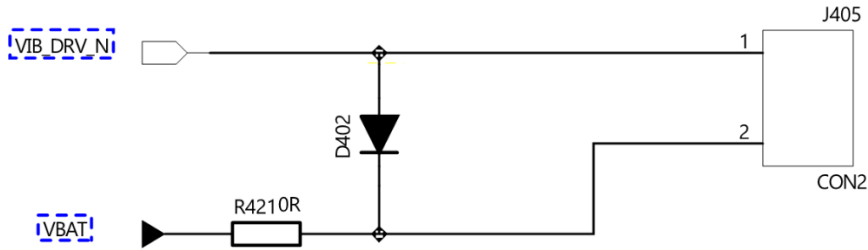

5.11. ADC

The two ADC's are connected to the VBAT through a voltage divider.

The following is the circuit diagram:

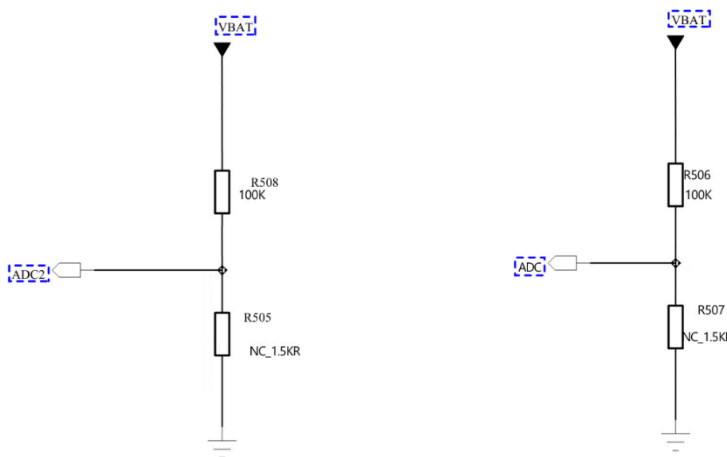

5.12. VCOIN

A backup battery for RTC could be connected to the module.

The following is the circuit diagram:

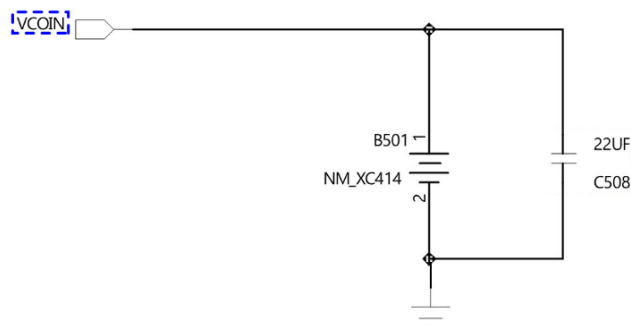

5.13. GPIO

A set of GPIOs are available on two connectors named J903 and J904.

The following is the circuit diagram:

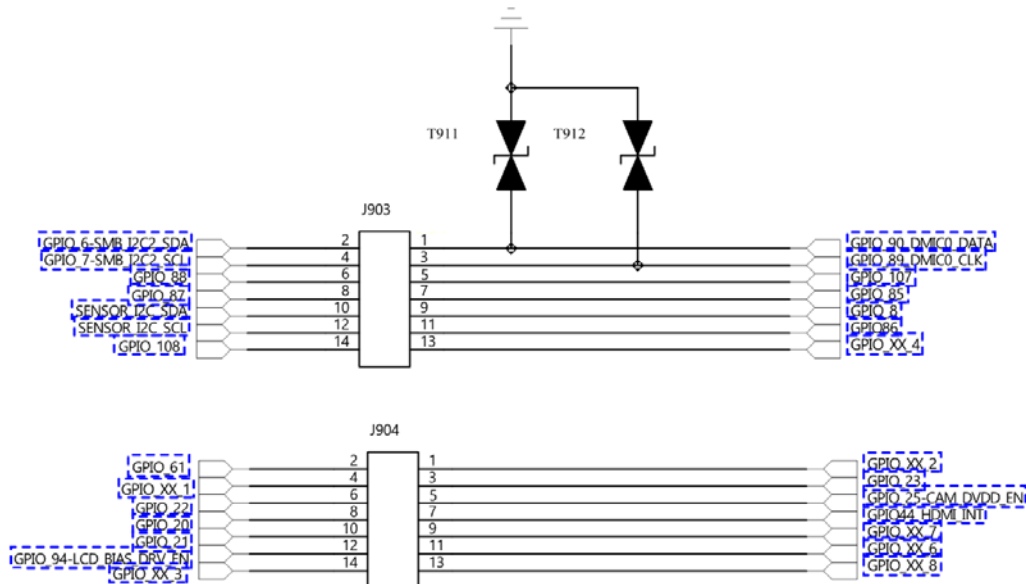

5.14. Board to Board Connectors

The Module's Interface can be connected to the EVB through two socket connectors from Panasonic with p/n AXK580147YG (80 PIN 0.5mm pitch 3.0mm height).

The following is the J901 and J902 Schematic and Pinout diagram:

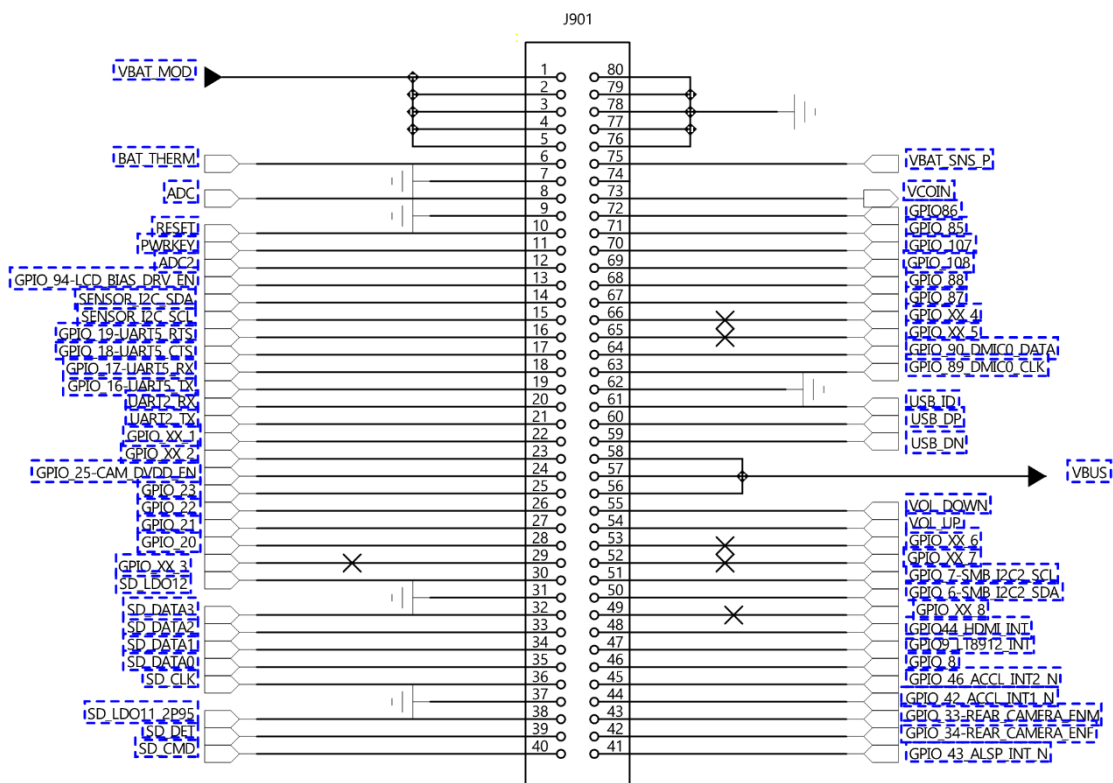

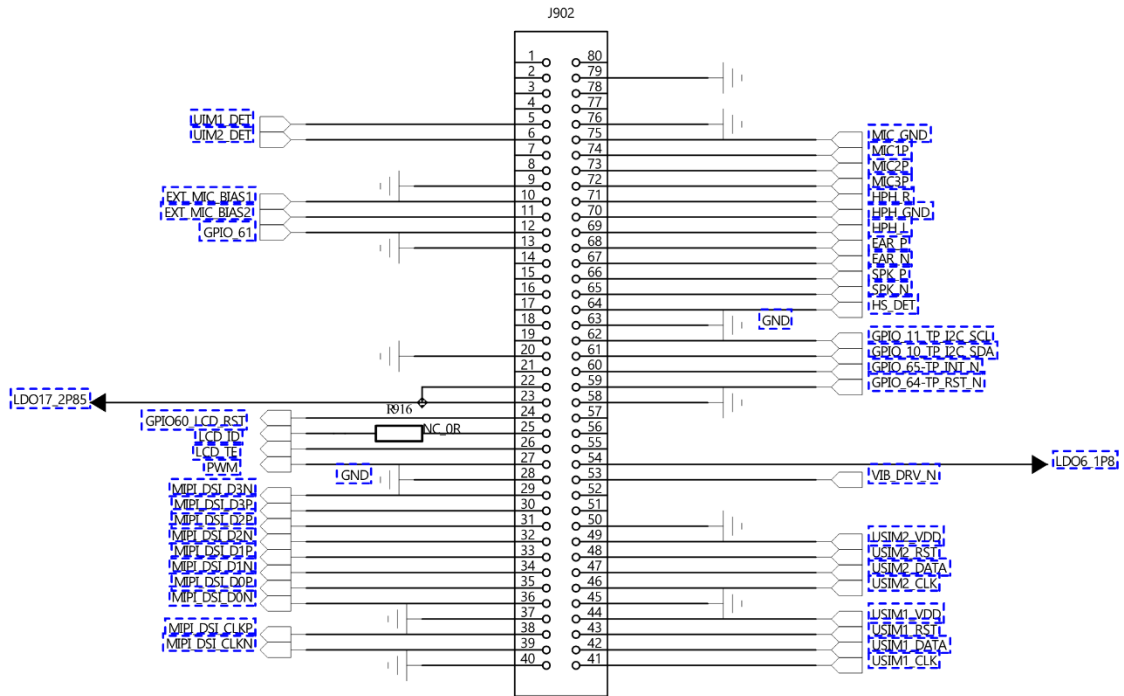

6. SE150A4 SMART MODULE INTERFACE

6.1. Description

For using SE150A4 Smart Module with EVB, Module is assembled on an interface board which is shown below.:



The SE150A4 Smart Module Interface could be connected to the EVB through two header connectors from Panasonic with p/n AXK680347YG (80 PIN 0.5mm pitch 3.0mm height) that are assembled on bottom side of the PCB. The connectors are named J901 and J902.

The interface board also has all the RF connectors, a Jumper for the Low level USB B00T, and two Cameras.

6.2. Main Connectors and Devices Layout

The following is the main connectors and devices on the SE150A4 Smart Module Interface:

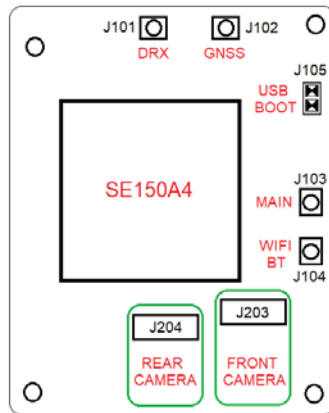

6.3. Camera

The SE150A4 Smart Module is supporting two Cameras (Front and Rear). Both are assembled on the module's Interface board and the interface is I2C.

6.3.1. Front Camera

The Front camera is a 13M pixel using an FP5510A IC with I2C address 0x20.

The following is the circuit diagram:

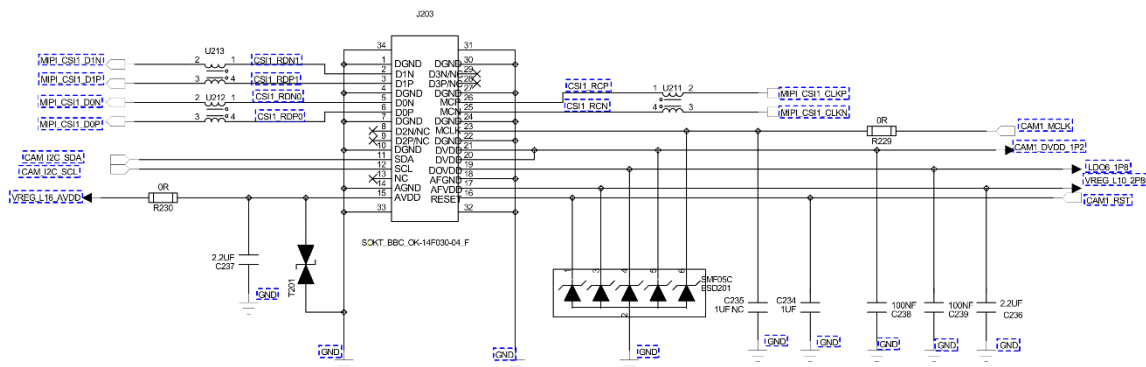

The following is the supply section diagram:

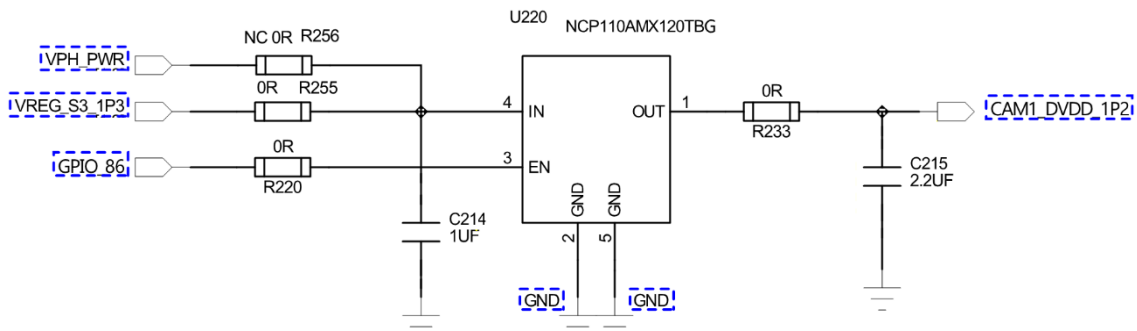

6.3.2. Rear Camera

The Rear camera is with 5M pixel and it is using the PE918 IC with I2C address 0x5A.

The following is the circuit diagram:

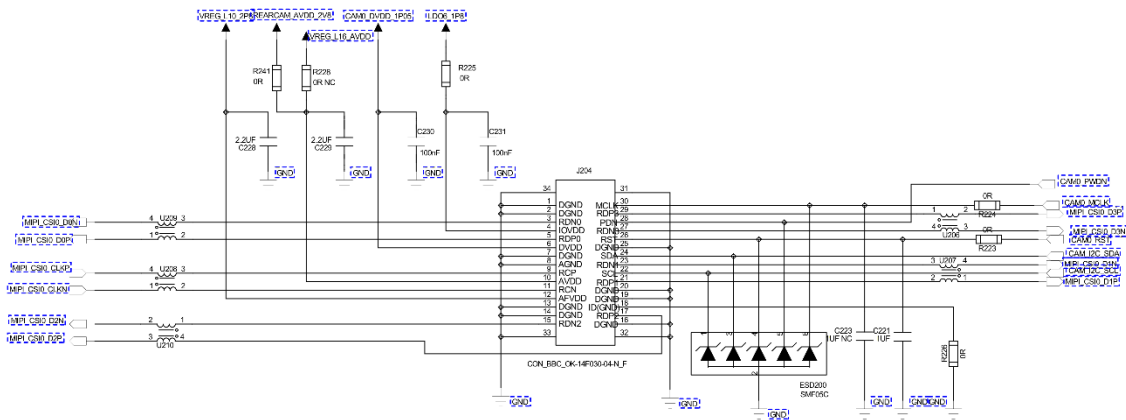

The following is the circuit diagram:

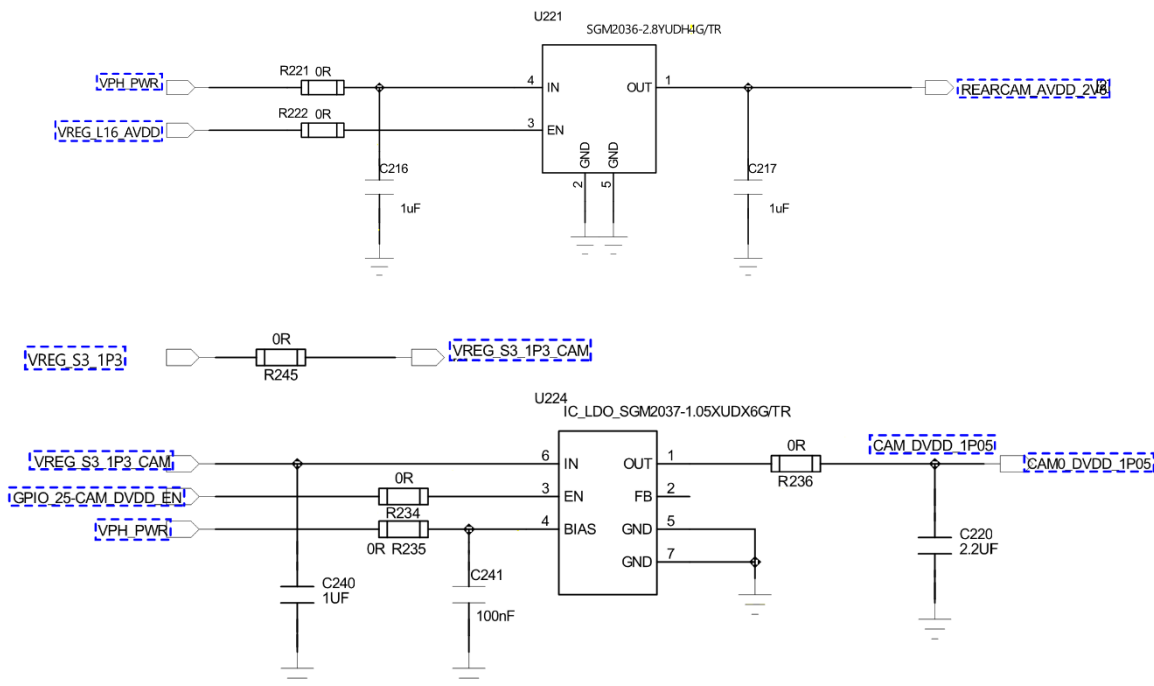

6.4. RF Connectors

The Interface board has four U.FL-R-SMT-1(80) for connecting Antennas. EVB kit contains 3 small RF cables (uFL to SMA female) for connecting antennas provided in the kit. To use antennas other than provided in the kit, refer to the module HW Design Guide for the antenna specifications.

Note/Tip: We recommended a passive antenna for GNSS, as the SE150A4 already includes a 20dB LNA.



If an active antenna is used, it requires additional circuit to supply power to the antenna and also a capacitor in series to the module to block the DC.

Please refer to the module's HW design Guide for the details.

6.5. USB BOOT

To perform a USB BOOT, connect the jumper J105 on the SE150A4 TE board.

The FORCE USB BOOT signal is active high.

The following is the circuit diagram:

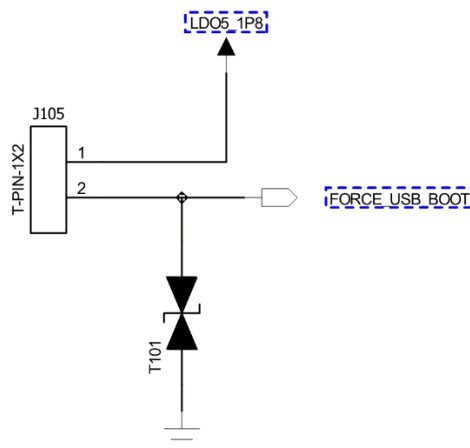

Note/Tip: By default the jumper is not mounted on J105.

7. PACKAGING

7.1. Tray

Telit SE150A4 Smart module supports tray packaging.

The following is the packaging process diagram:

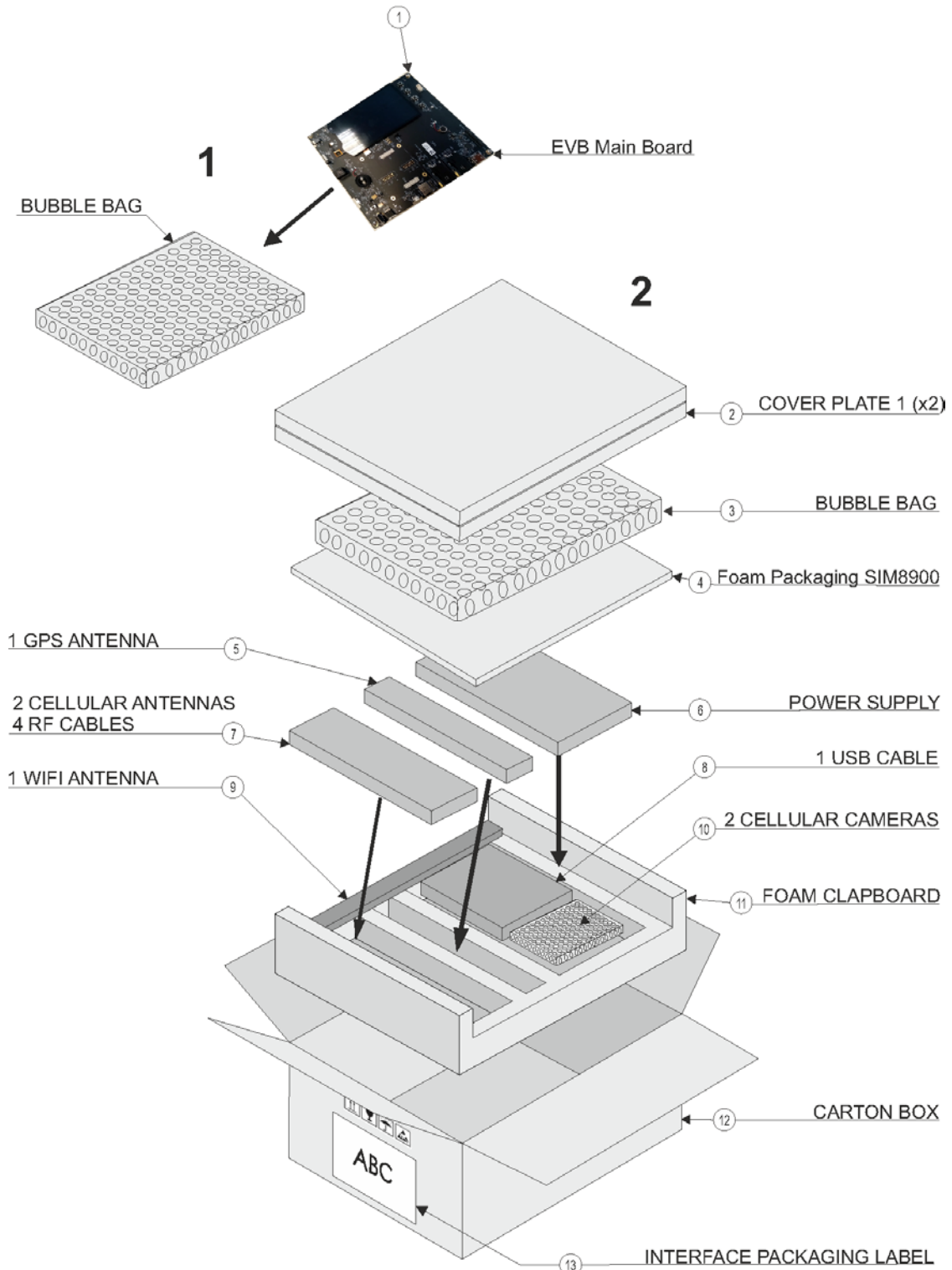

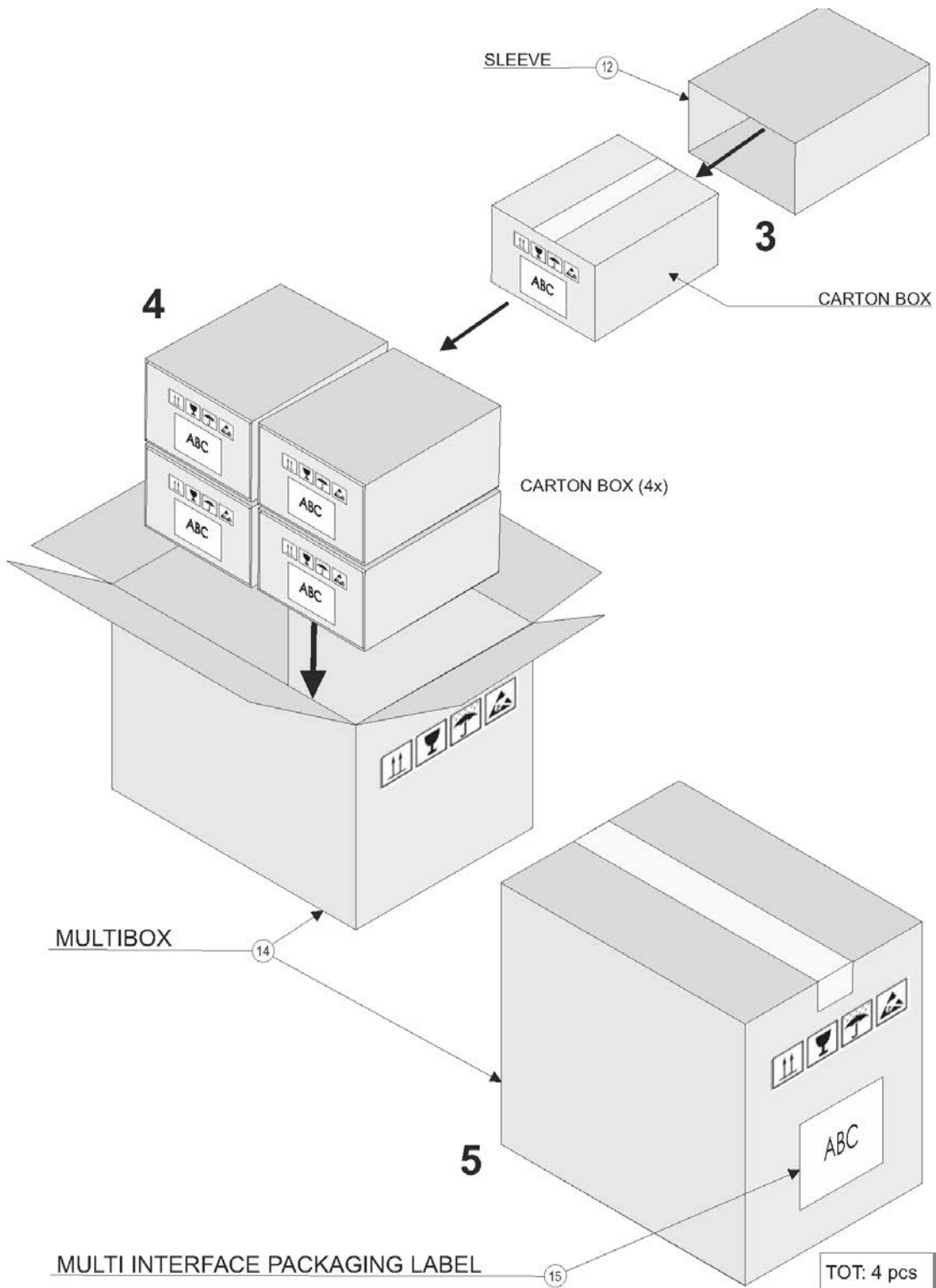

8. PRODUCT AND SAFETY INFORMATION

8.1. Copyrights and Other Notices

SPECIFICATIONS ARE SUBJECT TO CHANGE WITHOUT NOTICE

Although reasonable efforts have been made to ensure the accuracy of this document, Telit assumes no liability resulting from any inaccuracies or omissions in this document, or from the use of the information contained herein. The information in this document has been carefully checked and is believed to be reliable. Telit reserves the right to make changes to any of the products described herein, to revise it and to make changes from time to time with no obligation to notify anyone of such revisions or changes. Telit does not assume any liability arising from the application or use of any product, software, or circuit described herein; neither does it convey license under its patent rights or the rights of others.

This document may contain references or information about Telit's products (machines and programs), or services that are not announced in your country. Such references or information do not necessarily mean that Telit intends to announce such Telit products, programming, or services in your country.

8.1.1. Copyrights

This instruction manual and the Telit products described herein may include or describe Telit's copyrighted material, such as computer programs stored in semiconductor memories or other media. Laws in Italy and in other countries reserve to Telit and its licensors certain exclusive rights for copyrighted material, including the exclusive right to copy, reproduce in any form, distribute and make derivative works of the copyrighted material. Accordingly, any of Telit's or its licensors' copyrighted material contained herein or described in this instruction manual, shall not be copied, reproduced, distributed, merged or modified in any manner without the express written permission of the owner. Furthermore, the purchase of Telit's products shall not be deemed to grant in any way, neither directly nor by implication, or estoppel, any license.

8.1.2. Computer Software Copyrights

Telit and the 3rd Party supplied Software (SW) products, described in this instruction manual may include Telit's and other 3rd Party's copyrighted computer programs stored in semiconductor memories or other media. Laws in Italy and in other countries reserve to Telit and other 3rd Party SW exclusive rights for copyrighted computer programs, including – but not limited to – the exclusive right to copy or reproduce in any form the

copyrighted products. Accordingly, any copyrighted computer programs contained in Telit's products described in this instruction manual shall not be copied (reverse engineered) or reproduced in any manner without the express written permission of the copyright owner, being Telit or the 3rd Party software supplier. Furthermore, the purchase of Telit products shall not be deemed to grant either directly or by implication, estoppel, or in any other way, any license under the copyrights, patents or patent applications of Telit or other 3rd Party supplied SW, except for the normal non-exclusive, royalty free license to use arising by operation of law in the sale of a product.

8.2. Usage and Disclosure Restrictions

8.2.1. License Agreements

The software described in this document is owned by Telit and its licensors. It is furnished by express license agreement only and shall be used exclusively in accordance with the terms of such agreement.

8.2.2. Copyrighted Materials

The Software and the documentation are copyrighted materials. Making unauthorized copies is prohibited by the law. The software or the documentation shall not be reproduced, transmitted, transcribed, even partially, nor stored in a retrieval system, nor translated into any language or computer language, in any form or by any means, without prior written permission of Telit.

8.2.3. High Risk Materials

Components, units, or third-party goods used in the making of the product described herein are NOT fault-tolerant and are NOT designed, manufactured, or intended for use as on-line control equipment in the following hazardous environments requiring fail-safe controls: operations of Nuclear Facilities, Aircraft Navigation or Aircraft Communication Systems, Air Traffic Control, Life Support, or Weapons Systems ("High Risk Activities"). Telit and its supplier(s) specifically disclaim any expressed or implied warranty of fitness eligibility for such High Risk Activities.

8.2.4. Trademarks

TELIT and the Stylized T-Logo are registered in the Trademark Office. All other product or service names are property of their respective owners.

8.2.5. Third Party Rights

The software may include 3rd Party's software Rights. In this case the user agrees to comply with all terms and conditions imposed in respect of such separate software rights. In addition to 3rd Party Terms, the disclaimer of warranty and limitation of liability provisions in this License, shall apply to the 3rd Party Rights software as well.

TELIT HEREBY DISCLAIMS ANY AND ALL WARRANTIES EXPRESSED OR IMPLIED FROM ANY 3RD PARTY REGARDING ANY SEPARATE FILES, ANY 3RD PARTY MATERIALS INCLUDED IN THE SOFTWARE, ANY 3RD PARTY MATERIALS FROM WHICH THE SOFTWARE IS DERIVED (COLLECTIVELY "OTHER CODES"), AND THE USE OF ANY OR ALL OTHER CODES IN CONNECTION WITH THE SOFTWARE, INCLUDING (WITHOUT LIMITATION) ANY WARRANTIES OF SATISFACTORY QUALITY OR FITNESS FOR A PARTICULAR PURPOSE.

NO 3RD PARTY LICENSORS OF OTHER CODES MUST BE LIABLE FOR ANY DIRECT, INDIRECT, INCIDENTAL, SPECIAL, EXEMPLARY, OR CONSEQUENTIAL DAMAGES (INCLUDING WITHOUT LIMITATION LOST OF PROFITS), HOWEVER CAUSED AND WHETHER MADE UNDER CONTRACT, TORT OR OTHER LEGAL THEORY, ARISING IN ANY WAY OUT OF THE USE OR DISTRIBUTION OF THE OTHER CODES OR THE EXERCISE OF ANY RIGHTS GRANTED UNDER EITHER OR BOTH THIS LICENSE AND THE LEGAL TERMS APPLICABLE TO ANY SEPARATE FILES, EVEN IF ADVISED OF THE POSSIBILITY OF SUCH DAMAGES.

8.2.6. Waiver of Liability

IN NO EVENT WILL TELIT AND ITS AFFILIATES BE LIABLE FOR ANY DIRECT, INDIRECT, SPECIAL, GENERAL, INCIDENTAL, CONSEQUENTIAL, PUNITIVE OR EXEMPLARY INDIRECT DAMAGE OF ANY KIND WHATSOEVER, INCLUDING BUT NOT LIMITED TO REIMBURSEMENT OF COSTS, COMPENSATION OF ANY DAMAGE, LOSS OF PRODUCTION, LOSS OF PROFIT, LOSS OF USE, LOSS OF BUSINESS, LOSS OF DATA OR REVENUE, WHETHER OR NOT THE POSSIBILITY OF SUCH DAMAGES COULD HAVE BEEN REASONABLY FORESEEN, CONNECTED IN ANY WAY TO THE USE OF THE PRODUCT/S OR TO THE INFORMATION CONTAINED IN THE PRESENT DOCUMENTATION, EVEN IF TELIT AND/OR ITS AFFILIATES HAVE BEEN ADVISED OF THE POSSIBILITY OF SUCH DAMAGES OR THEY ARE FORESEEABLE OR FOR CLAIMS BY ANY THIRD PARTY.

8.3. Safety Recommendations

Make sure the use of this product is allowed in your country and in the environment required. The use of this product may be dangerous and has to be avoided in areas where:

- it can interfere with other electronic devices, particularly in environments such as hospitals, airports, aircrafts, etc.
- there is a risk of explosion such as gasoline stations, oil refineries, etc. It is the responsibility of the user to enforce the country regulation and the specific environment regulation.

Do not disassemble the product; any mark of tampering will compromise the warranty validity. We recommend following the instructions of the hardware user guides for correct wiring of the product. The product has to be supplied with a stabilized voltage source and the wiring has to be conformed to the security and fire prevention regulations. The product has to be handled with care, avoiding any contact with the pins because electrostatic discharges may damage the product itself. Same cautions have to be taken for the SIM, checking carefully the instruction for its use. Do not insert or remove the SIM when the product is in power saving mode.

The system integrator is responsible for the functioning of the final product. Therefore, the external components of the module, as well as any project or installation issue, have to be handled with care. Any interference may cause the risk of disturbing the GSM network or external devices or having an impact on the security system. Should there be any doubt, please refer to the technical documentation and the regulations in force. Every module has to be equipped with a proper antenna with specific characteristics. The antenna has to be installed carefully in order to avoid any interference with other electronic devices and has to guarantee a minimum distance from the body (20 cm). In case this requirement cannot be satisfied, the system integrator has to assess the final product against the SAR regulation.

The equipment is intended to be installed in a restricted area location.

The equipment must be supplied by an external specific limited power source in compliance with the standard EN 62368-1:2014.

The European Community provides some Directives for the electronic equipment introduced on the market. All of the relevant information is available on the European Community website:

https://ec.europa.eu/growth/sectors/electrical-engineering_en

9. ACRONYMS

TTSC	Telit Technical Support Centre
USB	Universal Serial Bus
HS	High Speed
DTE	Data Terminal Equipment
UMTS	Universal Mobile Telecommunication System
WCDMA	Wideband Code Division Multiple Access
HSDPA	High Speed Downlink Packet Access
HSUPA	High Speed Uplink Packet Access
UART	Universal Asynchronous Receiver Transmitter
HSIC	High Speed Inter Chip
SIM	Subscriber Identification Module
SPI	Serial Peripheral Interface
ADC	Analog – Digital Converter
DAC	Digital – Analog Converter
I/O	Input Output
GPIO	General Purpose Input Output
CMOS	Complementary Metal – Oxide Semiconductor
MOSI	Master Output – Slave Input
MISO	Master Input – Slave Output
CLK	Clock
MRDY	Master Ready
SRDY	Slave Ready
CS	Chip Select
RTC	Real Time Clock
PCB	Printed Circuit Board
ESR	Equivalent Series Resistance
VSWR	Voltage Standing Wave Ratio
VNA	Vector Network Analyzer

10. DOCUMENT HISTORY

Revision	Date	Changes
2	2021-17-05	Figure updates 7. Packaging image updates
1	2021-21-01	Figure updates 2.2 Content of the Kit 3. Functional Description 3.2 Main Connectors and Devices Layout 3.3 Switch and Jumpers Settings 6. SE150A4 Smart Module Interface
0	2020-11-11	First issue



Connect to our site and contact our technical support team for any question

www.telit.com



Telit



Telit reserves all rights to this document and the information contained herein. Products, names, logos and designs described herein may in whole or in part be subject to intellectual property rights. The information contained herein is provided "as is". No warranty of any kind, either express or implied, is made in relation to the accuracy, reliability, fitness for a particular purpose or content of this document. This document may be revised by Telit at any time. For most recent documents, please visit www.telit.com

Copyright © 2021, Telit