

GPS Engine Board

EB-870

EB-870 is an ultra miniature 10.5 x10.4 mm² GPS engine board. It provides superior navigation performance under dynamic conditions in areas with limited sky view like urban canyons. High sensitivity up to **-165dBm** for weak signal operation without compromising accuracy. EB-870 series is your best choice for embedded applications.



Key Features :

- Small form factor: 10.5 x 10.4 x 2.0 mm
- Lead-Free – RoHS/WEEE compliant
- High sensitivity -165dBm (With external LNA)
- Tracks 66-Channel of satellites
- Support QZSS and SBAS
- WAAS/EGNOS/MSAS/GAGAN supported
- RTCM ready
- AlwaysLocate™ location awareness technology
- EPO™ / HotStill™ orbit prediction
- EASY™ self-generated orbit prediction
- Fast Position Fix
- Ultra low power consumption
- FCC E911 compliance and A-GPS support

Applications :

- Handheld devices
- Automotive and Marine Navigation
- Automotive Navigator Tracking
- Emergency Locator
- Geographic Surveying
- Personal Positioning
- Sporting and Recreation
- Embedded applications : PDA, DSC, Smart phone, UMPC, PND, MP4

PIN Definition :

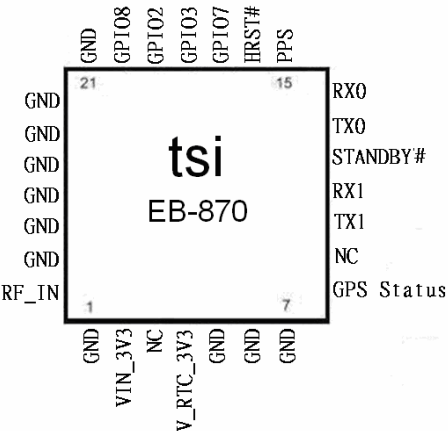

Ultimate



TRANSYSTEM INC.

An A+ supplier of RF microwave & GPS products

EB

Revision History

Rev.	Date	Description
0.3	11-29-2011	Update Standby current
0.2	08-31-2011	Update VCC and VRTC current
0.1	07-12-2011	Initial draft
	MM-DD-YYYY	

PRELIMINARY



EB-870 is ESD (electrostatic discharge) sensitive device and may be damaged with ESD or spike voltage. Please handle with care to avoid permanent malfunction or performance degradation.

Use of GPS Data and Services at the User's own risk

The GPS data and navigation services providers, system makers and integrated circuit manufacturers ("Providers") hereby disclaim any and all guarantees, representations or warranties with respect to the Global Positioning Systems (GPS) data or the GPS services provided herein, either expressed or implied, including but not limited to, the effectiveness, completeness, accuracy, fitness for a particular purpose or the reliability of the GPS data or services.

The GPS data or services are not to be used for safety of life applications or for any other application in which the accuracy or reliability of the GPS data or services could create a situation where personal injury or death may occur. Any use therewith are at the user's own risk. The Providers specifically disclaims any and all liability, including without limitation, indirect, consequential and incidental damages, that may arise in any way from the use of or reliance on the GPS data or services, as well as claims or damages based on the contravention of patents, copyrights, mask work and/or other intellectual property rights.

No part of this document may be copied, distributed, utilized, and transmitted in any form or by any means without expressed authorization of all Providers. The GPS data and services are in part or in all subject to patent, copyright, trade secret and other intellectual property rights and protection worldwide.

Transystem Inc. reserves the right to make change to specifications and product description without prior notification.

Table of Contents

1	Introduction.....	5
1.1	Key Features.....	5
1.2	Applications.....	5
1.3	Look & Feel.....	5
1.4	Labeling	5
2	Technical Description	6
2.1	Block Diagram.....	6
2.2	Pin Definition.....	7
2.3	Specifications	8
3	Electrical Characteristics	9
3.1	Absolute maximum ratings.....	9
3.2	Operating Conditions	9
3.3	DC Electrical Characteristics.....	9
4	Serial Port Interface.....	10
4.1	Protocol.....	10
4.1.1	NMEA Protocol.....	10
5	Dimension and Package.....	11
5.1	Mechanical Dimension.....	11
5.2	Recommend Layout Pattern	11
5.3	PIN Coordinates.....	12
5.4	Package.....	12
6	Recommended IR Profile	13
7	Application Information	14
7.1	GPS Antenna Recommendations	14
7.2	Application Circuit	14
7.3	PPS pin.....	15
7.4	Reset Signal.....	15
7.5	Battery Back-up	15
7.6	General GPS Receiver User's Tips.....	16
8	Quality and Reliability	17
8.1	Environmental Conditions	17
8.2	How to avoid ESD damage to module	17

EB-870 Data Sheet

1 Introduction

EB-870 is an ultra miniature 10.4 x10.5mm² GPS engine board with added features. It provides superior navigation performance under dynamic conditions in areas with limited sky view like urban canyons. High sensitivity up to -165dBm for weak signal operation without compromising accuracy. EB-870 is your best choice for embedded applications.

1.1 Key Features

- Small form factor: 10.4 x 10.5 x 2.0 mm
- Lead-Free – RoHS/WEEE compliant
- High sensitivity -165dBm (with external LNA)
- Tracks 66-Channel of satellites
- Fast Position Fix
- Ultra low power consumption
- AlwaysLocate™ location awareness technology
- EPO™ / HotStill™ orbit prediction
- EASY™ self-generated orbit prediction

1.2 Applications

- Handheld devices
- Automotive and Marine Navigation
- Automotive Navigator Tracking
- Emergency Locator
- Geographic Surveying
- Personal Positioning
- Sporting and Recreation
- Embedded applications such as: PDA, DSC, Smart phone, UMPC, PND, MP4

1.3 Look & Feel



1.4 Labeling

There are 4 lines of top marking on the GPS engine and they are :

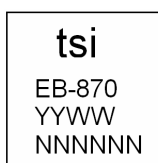

- Line #1: TSI company icon
- Line #2: Model number, i.e. EB-870
- Line #3: Date code, the year and week when the product is built
- Line #4: Lot control code for TSI internal use

2 Technical Description

2.1 Block Diagram

EB-870 Block Diagram

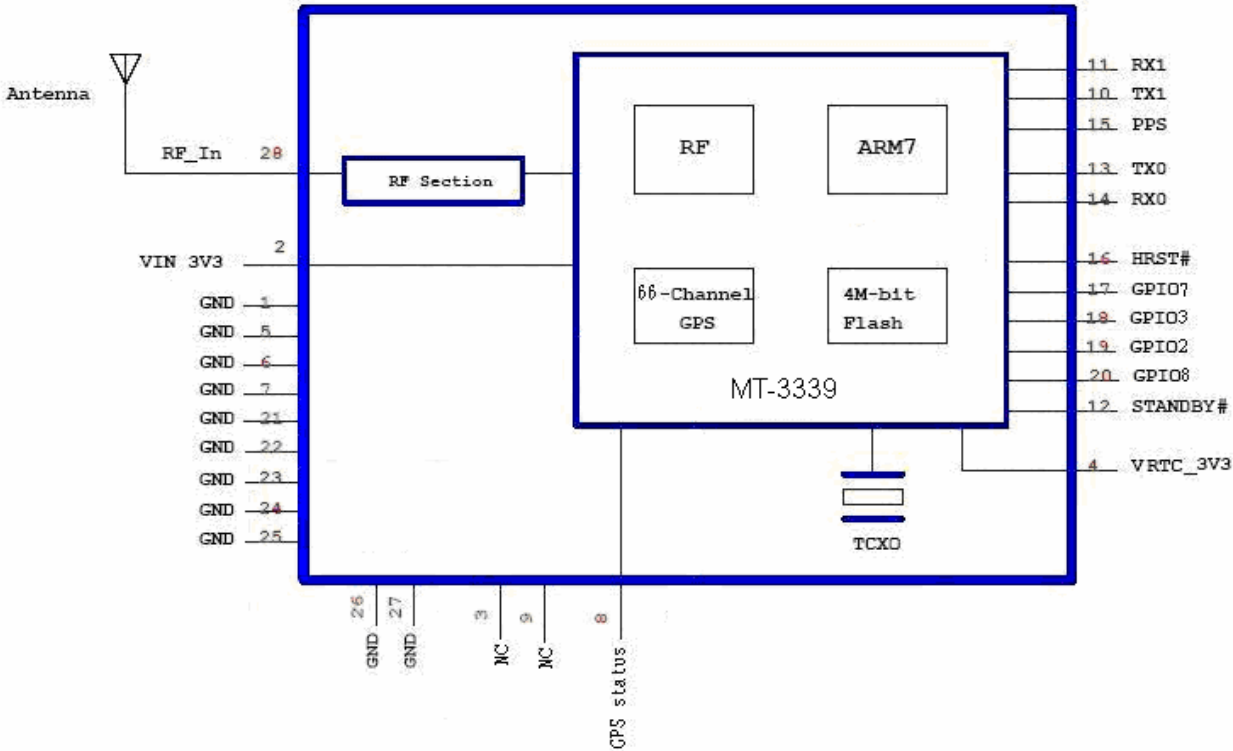

PR

EB-870 Data Sheet

2.2 Pin Definition

Pin#	Signal Name	Type	Description
1	GND	P	Ground
2	VIN_3V3	P	Power Supply 2.8~4.2V DC
3	NC	NC	NC
4	VRTC_3V3	P	RTC power 2.0~4.2V, 20uA @ 3.3V typical
5	GND	P	Ground
6	GND	P	Ground
7	GND	P	Ground
8	GPS Status	O	GPS status, blink when GPS has position fix
9	NC	NC	NC
10	TX1	O	UART port 1 output
11	RX1	I	UART port 1 input (RTCM only)
12	STANDBY#	I	Falling edge trigger
13	TX0	O	UART port 0 for NMEA output
14	RX0	I	UART port 0 input
15	PPS	O	PPS
16	HRST#	I	GPS reset, active low. Internal pull high
17	GPIO3 / SO	I/O*	General input / output ; SPI serial output
18	GPIO4 / SCK	I/O*	General input / output ; SPI clock output
19	GPIO5 / SCS#	I/O*	General input / output ; SPI select, active low
20	GPIO2 / SI	I/O*	General input / output ; SPI serial input
21	GND	P	Ground
22	GND	P	Ground
23	GND	P	Ground
24	GND	P	Ground
25	GND	P	Ground
26	GND	P	Ground
27	GND	P	Ground
28	RF_IN	I	Antenna port, L1, 1575.42MHz, 50 ohm DC O/P: 2.8V Current \leq 25mA

Note : 1) P: Power, I: Input, O: Output, I/O: Input or Output
2) GPIO current output default : 4mA, Max : 16mA

EB-870 Data Sheet

2.3 Specifications

Item	Description
General	L1 frequency, C/A code (SPS) 66 independent tracking channels
Sensitivity	-165dBm /Tracking; -148dBm /Acquisition
Update Rate	Up to 5Hz
Accuracy	Without aid: 3.0m 2D-RMS <3m CEP (50%) without SA (horizontal) DGPS (WAAS, EGNOS, MSAS, RTCM): 2.5m
Acquisition (open sky)	Cold Start: <35sec Warm Start: <34sec Hot Start: <1.5sec
Reacquisition	< 1sec
Dynamics	Altitude : 18000m (max.) Velocity : 515m/sec (max.) Vibration : 4G (max.)
Supply Voltage	DC 2.8~4.2 V
Power Consumption	< 15 mA @ 3.3V (w/o Active ANT) / Tracking
Backup Battery	DC 2.0~4.2V, 20 uA@3.3V typical
NMEA Message	NMEA0183 v3.1 baud rate 4800/9600/.../115200, default 9600 Selectable Output: GGA, GLL, GSA, GSV, RMC, and VTG
Datum	Default WGS-84
Antenna	External Active Antenna Output Voltage: 2.8 VDC or Passive Antenna
Serial Interface	UART
Operating Temp.	-40°C to 85°C
Storage Temp.	-40°C to 85°C
Operating Humidity	≤95%, non condensing
Mounting	SMT Type, 28 Pin
Dimension	10.5 x 10.4 x 2.0(H) mm

3 Electrical Characteristics

3.1 Absolute maximum ratings

Symbol	Parameter	Min	Max	Unit
Vcc	power supply	-0.3	+4.3	V
Vin	voltage to any pin	-0.3	+3.6	V
Iov	input current on any pin	-10	10	mA
Itdv	absolute sum of all input currents during overload condition		200	mA
Tst	storage temperature	-40	85	°C
Iant	antenna supply current	0	50	mA

Table 3-1 Absolute maximum ratings

Note:

- (1) Stresses beyond absolute maximum ratings may cause permanent damage to the device.
- (2) Exposure to absolute maximum rating conditions for extended period may affect device reliability.

3.2 Operating Conditions

Pin	Description	Min	Typical	Max	Unit
4	V_RTC_3V3	2.0		4.2	V
	Tracking Current (2)		20		uA
	Quiescent Current		2		uA
2	VIN_3V3	2.8	3.3	4.2	V
	Peak Acquisition Current (1)			18	mA
	Tracking Current (2)		15		mA
	Standby Current			1	mA

Table 3-2 Operating Conditions

Note:

- (1) Peak acquisition current is the maximum current with passive antenna.
- (2) Tracking current is the average current with passive antenna includes tracking and post acquisition portion.

3.3 DC Electrical Characteristics

Symbol	Parameter	Min	Max	Unit
1PPS, GPS Status, TX1, TX0, GPIO 2,3,4,5	Voh	2.4	3.1	V
	Vol	-0.3	0.4	V
RX1, RX0, STANDBY#, HRST#	Vih	2.0	3.6	V
	Vil	-0.3	0.8	V

Table 3-3 DC Electrical characteristics

4 Serial Port Interface

EB-870 provides 2-wire digital UART port for communication of GPS position data using NMEA protocol or MTK extension protocol. UART port is capable of 4800 to 115200 baud rate.

4.1 Protocol

EB-870 is default to support standard NMEA-0183 protocol. In addition, a series of MTK extensions (PMTK messages) have been developed that can be used to provide extended capabilities common to many applications. Please refer to "GPS Engine Board UART Port Command" for detailed command information.

4.1.1 NMEA Protocol

EB-870 is capable of supporting following NMEA formats:

NMEA Prefix	Format	Direction
\$GPGGA	GPS fix data	Out
\$GPGLL	Geographic position Latitude / Longitude	Out
\$GPGSA	GNSS DOP and active satellites	Out
\$GPGSV	Satellites in view	Out
\$GPRMC	Recommended minimum specific GNSS data	Out
\$GPVTG	Velocity and track over ground	Out
\$GPZDA	Date and time	Out

5 Dimension and Package

5.1 Mechanical Dimension

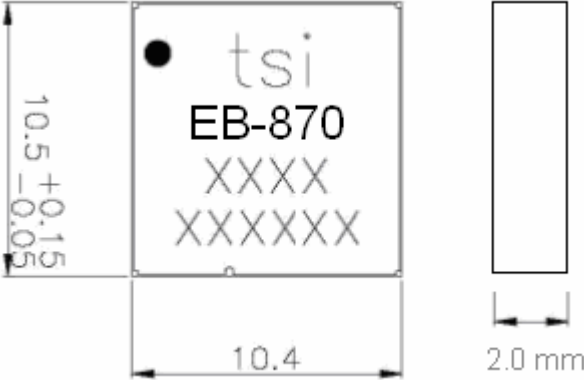

5.2 Recommend Layout Pattern

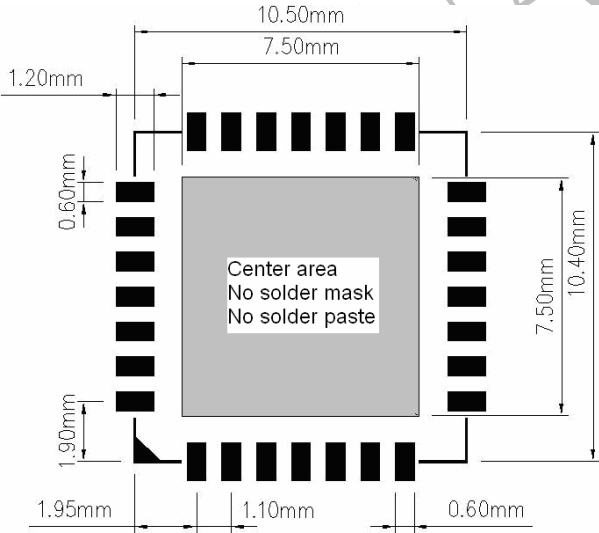

EB-870 Data Sheet

5.3 PIN Coordinates

Unit:mm

Pin #	X	Y	Pin #	X	Y
1	0.00	0.00	15	6.60	10.40
2	1.10	0.00	16	5.50	10.40
3	2.20	0.00	17	4.40	10.40
4	3.30	0.00	18	3.30	10.40
5	4.40	0.00	19	2.20	10.40
6	5.50	0.00	20	1.10	10.40
7	6.60	0.00	21	0.00	10.40
8	8.55	1.90	22	-1.95	8.50
9	8.55	3.00	23	-1.95	7.40
10	8.55	4.10	24	-1.95	6.30
11	8.55	5.20	25	-1.95	5.20
12	8.55	6.30	26	-1.95	4.10
13	8.55	7.40	27	-1.95	3.00
14	8.55	8.50	28	-1.95	1.90

5.4 Package

EB-870 GPS modules come in tray package suitable for pick and place machines. Each tray contains total 168 pieces of EB-870 and maximum 10 trays are stacked together before sealed in ESD protective vacuum dry pack to provide protection against moisture and ESD during storage and shipment.

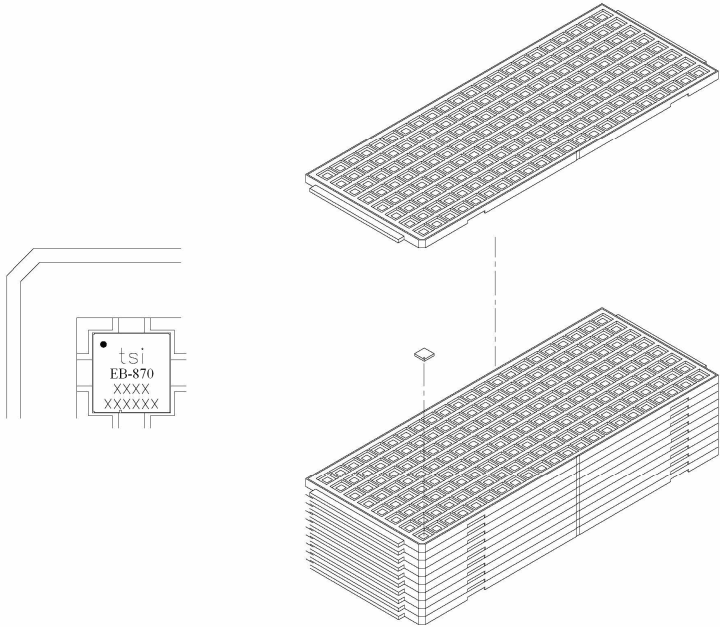

EB-870 Data Sheet

6 Recommended IR Profile

Follow below IR profile for reflow during SMT assembly for EB-870.

- Ramp-down rate : 6 °C /sec. max.
- Time 25 °C to peak temperature : 8 minutes max.
- Cycle interval : 5 minus

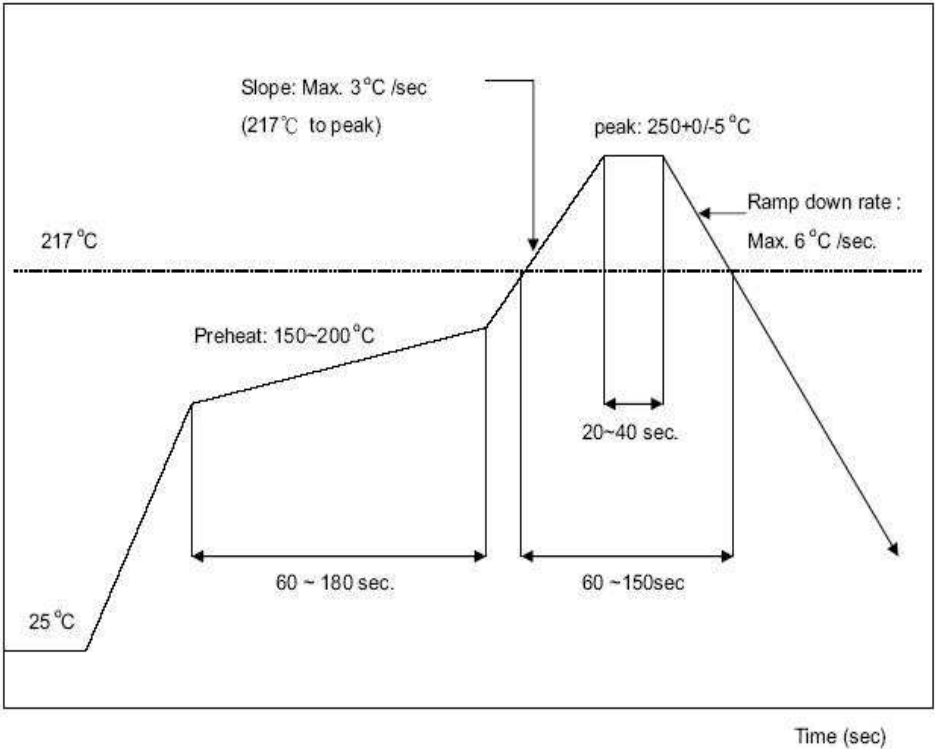

PR

7 Application Information

7.1 GPS Antenna Recommendations

Follow below recommendations when choosing GPS antenna for EB-870 for best system performance. Transystem also offers active antenna products for optimal performance with EB-870. For details, please contact your Transystem sales contact directly.

- Use active antenna that works with 2.8V power supply
- Receiving frequency $1575.42 \pm 1.032\text{MHz}$
- Polarization RHCP (right hand circular polarized)
- Output impedance = 50 Ohm
- $15\text{dB} \leq \text{LNA Gain} \leq 20\text{dB}$
- Noise figure $\leq 1.5\text{dB}$
- Connector: surface mounted on main PCB, Ipex or MMCX

7.2 Application Circuit

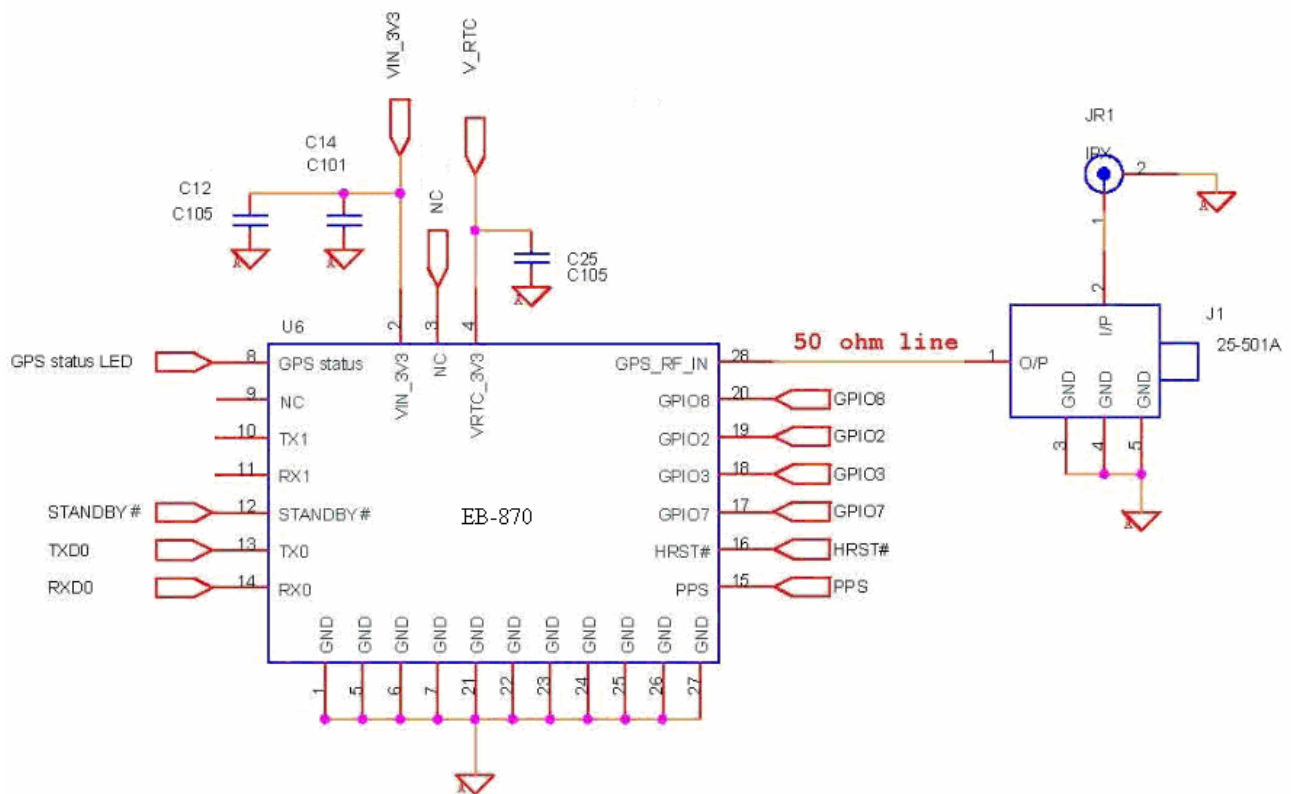

【Note 1】 : VRTC_3V3 (pin#4) could connect to 3.3V DC power supply or battery directly. (EB-870)

7.3 PPS pin

GPS also provides accurate timing information due to the synchronized atomic clocks in the GPS satellites. In addition to the current date and time is transmitted in NMEA sentences (UTC), an accurate timing signal is provided via the PPS pin (pin #15) of the EB-870 GPS receiver.

Under good signal conditions the 1PPS signal comes between 620ns and 710ns after the full GPS system second which is accurately (around 10ns) synchronized to UTC. Therefore the 1 second clock can be derived and maintained within around 90ns under good signal conditions.

The 1PPS signal accuracy directly relates to the position accuracy. The GPS signals travel at the speed of light, therefore a position inaccuracy directly translates into 1PPS inaccuracies.

10 m position deviation \approx 33 ns 1PPS deviation (typically)

100 m position deviation \approx 333 ns 1PPS deviation (typically)

The 1PPS signal is provided on an “as it is” basis with no accuracy specification.

7.4 Reset Signal

The HRST# pin (pin #16) can be used to reset the EB-870 module. Resetting the module will result in a restart of the complete firmware.

The EB-870 is equipped with a voltage monitoring circuit that generates a proper power-on reset signal at the appropriate threshold and delay. Usually there is no need to deal with the reset input externally, thus the general advice is to leave this pin open.

7.5 Battery Back-up

VRTC_3V3 input (pin #4) provides back-up power for the RTC and SRAM of the GPS receiver module. Typical quiescent current 2uA allows the use of a separate battery or a “Supercap”. The VRTC_3V3 pin draws 20uA typical under normal operation

7.6 General GPS Receiver User's Tips

In general, GPS receiver performs best in open space where it can see clean sky. Weather condition will affect GPS reception – rain & snow contribute to worsen sensitivity.

If the satellite signals can not be locked or experiencing receiving problem (while in urban area), following steps are suggested:

- Use of external active antenna if that option exists.
- Move to another open space or reposition GPS receiver toward the direction with least blockage.
- Move the GPS receiver away from the interference sources.
- Wait until the weather condition is improved.

Some vehicles using heavy metallic sun protecting coating on windshields may affect GPS signal reception.

- Driving in and around high buildings may affect signal reception.
- Driving in tunnels or in building structure may affect signal reception.
- When GPS receiver is moving, it will take longer time to get position fix. Wait for satellite signals to be locked at a fixed point when first power-on the GPS receiver to ensure quick GPS position fix.

PRELIMINARY

8 Quality and Reliability

Each module is electrically tested prior to packing and shipping to ensure state of the art product quality and best GPS receiver performance and accuracy.

8.1 Environmental Conditions

Operating temperature	-40 ~ +85°C
Operating humidity	Max. 95%, non-condensing
MSL JEDEC (Moisture Sensitivity Level)	3
Storage temperature	-40 ~ +85°C
Storage	12 months in original package.

8.2 How to avoid ESD damage to module

- Any person handling the module should be grounded either with a wrist strap or ESD-protective footwear used in conjunction with a conductive or static-dissipative floor or floor mat.
- The work surface where devices are placed for handling, processing, testing, etc., must, be made of static-dissipative material and be grounded to ESD ground.
- All insulator materials must either be removed from the work area or must be neutralized with an ionizer. Static-generating clothing must be covered with an ESD-protective smock.
- When module are being stored, transferred between operations or workstations, or shipped, they must be kept in a Faraday shield container with inside surfaces (surfaces touching the module) that are static-dissipative.

EB-870 Data Sheet

Contact Information

Transystem Inc.
No. 1-2 Li-Hsin Rd. I,
Science-Based Industrial Park,
Hsinchu 300, Taiwan, R.O.C.
t : +886.3.578.0393
f : +886.3.578.4111
www.transystem.com.tw
sales@transystem.com.tw

PRELIMINARY